

Series
SN200 Wiegand
SN210 OSDP
Exit Device
Including PE Series and
56- Electric Latch Retraction

Attention Installer:

Please read these instructions carefully to prevent missing important steps.

Improper installations may result in damage to the lock and void the factory warranty.

The accuracy of the door preparation is critical for proper functioning and security of this lock.

Misalignment can cause premature wear and a lessening of security.

For specific security information, please contact your local ASSA ABLOY Door Security Solutions sales consultant or call 800-810-WIRE.

Table of Contents

1	Regulatory Compliance.....	3
2	Warning.....	3
3	Specifications	4
4	Wiring Diagrams	5
5	Installation Instructions SN200/210 (PE)8600	9
6	Installation Instructions SN200/210 (PE)8700	18
7	Installation Instructions SN200/210 (PE)8800	25
8	Installation Instructions SN200/210 (PE)8900	34
9	56- Configuration Check	43
10	Operational Check.....	44

1 Regulatory Compliance

Changes or modifications to this unit not expressly approved by the party responsible for compliance could void the user's authority to operate the equipment.

FCC:

This equipment has been tested and found to comply with the limits for a Class B digital device, pursuant to Part 15 of the FCC Rules. These limits are designed to provide reasonable protection against harmful interference in a residential installation. This equipment generates, uses, and can radiate radio frequency energy and, if not installed and used in accordance with the instructions, may cause harmful interference to radio communications. However, there is no guarantee that interference will not occur in a particular installation. If this equipment does cause harmful interference to radio or television reception, which can be determined by turning the equipment off and on, the user is encouraged to try to correct the interference by one or more of the following measures:

- Reorient or relocate the receiving antenna.
- Increase the separation between the equipment and receiver.
- Connect the equipment into an outlet on a circuit different from that to which the receiver is connected.
- Consult the dealer or an experienced radio/TV technician for help.

Industry Canada:

This Class B digital apparatus meets all requirements of the Canadian Interference Causing Equipment Regulations. Operation is subject to the following two conditions: (1) this device may not cause harmful interference, and (2) this device must accept any interference received, including interference that may cause undesired operation.

Cet appareillage numérique de la classe B répond à toutes les exigences de l'interférence canadienne causant des règlements d'équipement. L'opération est soumise aux deux conditions suivantes: (1) ce dispositif peut ne pas causer l'interférence nocive, et (2) ce dispositif doit accepter n'importe quelle interférence reçue, y compris l'interférence qui peut causer l'opération peu désirée.

This equipment complies with FCC radiation exposure limits set forth for an uncontrolled environment. This equipment should be installed and operated with minimum distance 20cm between the radiator and your body. This transmitter must not be co-located or operating in conjunction with any other antenna or transmitter.

Cet équipement est conforme aux limites d'exposition aux radiations de la FCC définies pour un environnement non contrôlé. Cet équipement doit être installé et utilisé à une distance minimale de 20 cm entre le radiateur et votre corps. Cet émetteur ne doit pas être co-localisé ou fonctionner en conjonction avec une autre antenne ou un autre émetteur.

Under Industry Canada regulations, this radio transmitter may only operate using an antenna of a type and maximum (or lesser) gain approved for the transmitter by Industry Canada. To reduce potential radio interference to other users, the antenna type and its gain should be so chosen that the equivalent isotropically radiated power (e.i.r.p.) is not more than that necessary for successful communication. Conformément à la réglementation d'Industrie Canada, le présent émetteur radio peut fonctionner avec une antenne d'un type et d'un gain maximal (ou inférieur) approuvé pour l'émetteur par Industrie Canada. Dans le but de réduire les risques de brouillage radioélectrique à l'intention des autres utilisateurs, il faut choisir le type d'antenne et son gain de sorte que la puissance isotrope rayonnée équivalente (p.i.r.e.) ne dépasse pas l'intensité nécessaire à l'établissement d'une communication satisfaisante.

2 Warning



This product can expose you to lead which is known to the state of California to cause cancer and birth defects or other reproductive harm. For more information go to: www.P65warnings.ca.gov.

Ce produit peut vous exposer au plomb qui, dans l'état de la Californie, est reconnu pour causer le cancer, des anomalies congénitales ou d'autres problèmes de reproduction.

Pour plus d'informations, visitez: www.P65warnings.ca.gov.



Any retrofit or other field modification to a fire rated opening can potentially impact the fire rating of the opening, and SARGENT Manufacturing makes no representations or warranties concerning what such impact may be in any specific situation. When retrofitting any portion of an existing fire rated opening, or specifying and installing a new fire-rated opening, please consult with a code specialist or local code official (Authority Having Jurisdiction) to ensure compliance with all applicable codes and ratings.

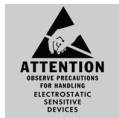

To avoid possible damage from electrostatic discharge (ESD), some basic precautions should be used when handling electronic components:

- Minimize build-up of static by touching and/or maintaining contact with unpainted metal surfaces such as door hinges, latches, and mounting plates especially when mounting electronic components such as readers and controllers onto the door.
- Leave components (reader and controller) protected in their respective anti-static bags until ready for installation
- Do not touch pins, leads or solder connections on the circuit boards

The system shall not be installed in the fail-secure mode unless permitted by the local authority having jurisdiction and shall not interfere with the operation of Listed panic hardware.

3 Specifications

- UL Listed* - UL 294 Indoor Use
- CUL Listed - S319: Class 1
- ANSI/BHMA A156.25 Listed Grade 1 Compliant

*UL294, S319, & BHMA A156.25 not applicable to SN200 with Non-UL294 Configuration option

- UL 294 Access Control Ratings:

Destructive Attack	Level 1
Line Security	Level 1
Endurance	Level 4
Standby Power	Level 1

UL testing was conducted on product powered by UL Listed model 9001GR/AC injector; manufactured by Microsemi Corp.

Electrical Specifications

12/24VDC System

	12V		24V	
	Average	Peak	Average	Peak
Reader*	75mA	250mA	n/a	n/a
Actuator	15mA	500mA	15mA	500mA
56-ELR	n/a	n/a	250mA dogged	1A inrush 600mA during retraction

*Maximum AVG - RMS current draw during continuous card reads
Not evaluated by UL.

Peak - highest instantaneous current draw during RF communication

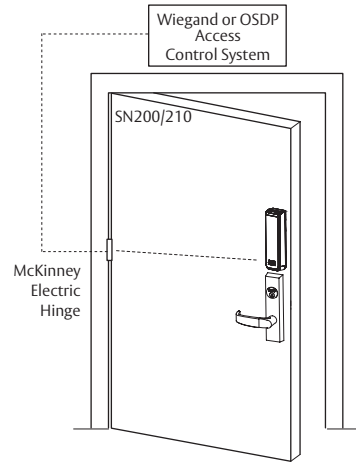

The reader requires 12VDC for power, and the 56-Electric Latch Retraction (ELR) Exit Device requires 24VDC

OSDP† and Wiegand Wire Specifications

Total One-Way Length of Wire Run (ft)	Wire Gauge Chart 12VDC Load Current @ 12VDC							
	1/4A	1/2A	3/4A	1A	1-1/4A	1-1/2A	2A	3A
100	20	18	16	14	14	12	12	10
150	18	16	14	12	12	12	10	—
200	16	14	12	12	10	10	—	—
250	16	14	12	10	10	10	—	—
300	16	12	12	10	10	—	—	—
400	14	12	10	—	—	—	—	—
500	14	10	10	—	—	—	—	—
750	12	10	—	—	—	—	—	—
1,000	10	—	—	—	—	—	—	—
1,500	10	—	—	—	—	—	—	—

Total One-Way Length of Wire Run (ft)	Wire Gauge Chart 24VDC Load Current @ 24VDC							
	1/4A	1/2A	3/4A	1A	1-1/4A	1-1/2A	2A	3A
100	24	20	18	18	16	16	14	12
150	22	18	16	16	14	14	12	10
200	20	18	16	14	14	12	12	10
250	18	16	14	14	12	12	12	10
300	18	16	14	12	12	12	10	—
400	18	14	12	12	10	10	—	—
500	16	14	12	10	10	—	—	—
750	14	12	10	10	—	—	—	—
1,000	14	10	10	—	—	—	—	—
1,500	12	10	—	—	—	—	—	—

†Recommended wire specifications for OSDP: Four (4) conductor twisted pair overall shield such as UL approved, Belden 3107A or equivalent is recommended to remain fully TIA-485 compliant at maximum supported baud rates and cable distances. Belden 82842, Liberty Wire & Cable 24-29_P485-WHT, West Penn Wire D254852, and CAT6 cable have been found to be suitable in typical applications and installations, including lower baud rates and cabling distances.

This product is not intended for outside wiring as covered by Article 800 in the National Electrical Code, NFPA 70.

Wiring methods shall be in accordance with the National Electrical Code (ANSI/NFPA70), CSA 22.1, Canadian Electrical Code (CEC), Part I, Safety Standard for Electrical Installations, local codes and the authorities having jurisdiction.

Both reader and actuator current must be taken into account when determining wire length and gauge. OSDP installations may be more limited due to fewer cable options.

For OSDP cable lengths greater than 200 ft (61 m) or EMF interference, install 120Ω +/- 2Ω resistor across RS-485 termination ends.

Copyright © 2020-2023 Sargent Manufacturing Company, an ASSA ABLOY Group company. All rights reserved. Reproductions in whole or in part without express written permission of Sargent Manufacturing Company is prohibited.

01/31/23

4 Wiring Diagrams

Product	8 PIN CONNECTOR								4 PIN CONNECTOR			
	1-Black	2-Red	3-White	4-Green	5-Orange	6-Blue	7-Brown	8-Yellow	1-Violet	2-Gray	3-Pink	4-Tan
ACCESS CONTROL DEVICES: SN200/210 Lockset, Electrolynx wire Color / Function assignments												
	12VDC (Reader)		Communication Type		RX	RX	EGND	Function*	12/24 VDC (LOCK RELAY)		DPS	DPS
SN200 (UL294)	NEG	POS	WIEGAND DATA_1	WIEGAND DATA_0	NO	COM	EGND	TAMPER	NEG	POS	NC	COM
SN200								GREEN LED				
SN210			OSDP RS-485B	OSDP RS-485A				n/a				

*Diagrams on following pages

If your lock is configured with End of Line Resistors, reference instruction sheet A8191 for the wiring of RX & DPS outputs.

Wiegand Operation Mode:

- Red LED 'ON' when powered.
- Presenting a compatible credential causes LED to briefly turn green and then return to red state.

UL294 / TAMPER Configuration:

- Connect Yellow TAMPER wire from Electrolynx cable to desired EAC panel control line. Reference Diagram #1.

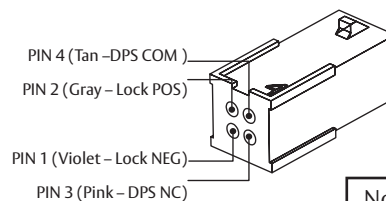
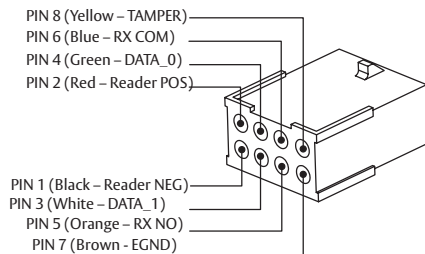

Note: NC = Normally Closed
NO = Normally Open

Non-UL294 Configuration:

- Connect GREEN_LED input to switch controlled by panel. Shorting GREEN_LED to READER_NEG (Black) with panel switch will override reader LED to keep it green.

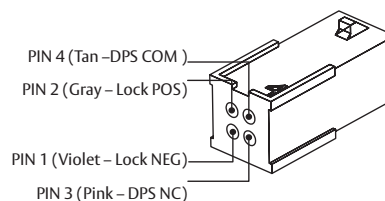
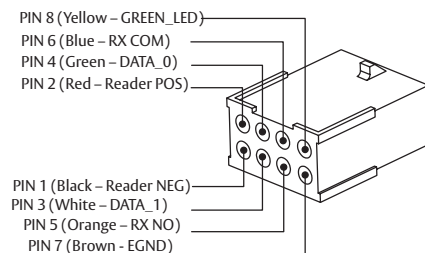

4 Wiring Diagrams (Continued)

SN200 Wiegand UL294/TAMPER Configuration Application Diagram #1

Tamper will trigger when reader is removed from door and tamper wiring is connected at the panel.

12/24VDC System

	12V		24V	
	Average	Peak	Average	Peak
Reader*	75mA	250mA	n/a	n/a
Actuator	15mA	500mA	15mA	500mA

Reader Electronics Requires 12VDC Filtered and Regulated

*Maximum AVG - RMS current draw during continuous card reads
Not evaluated by UL.
Peak - highest instantaneous current draw during RF communication

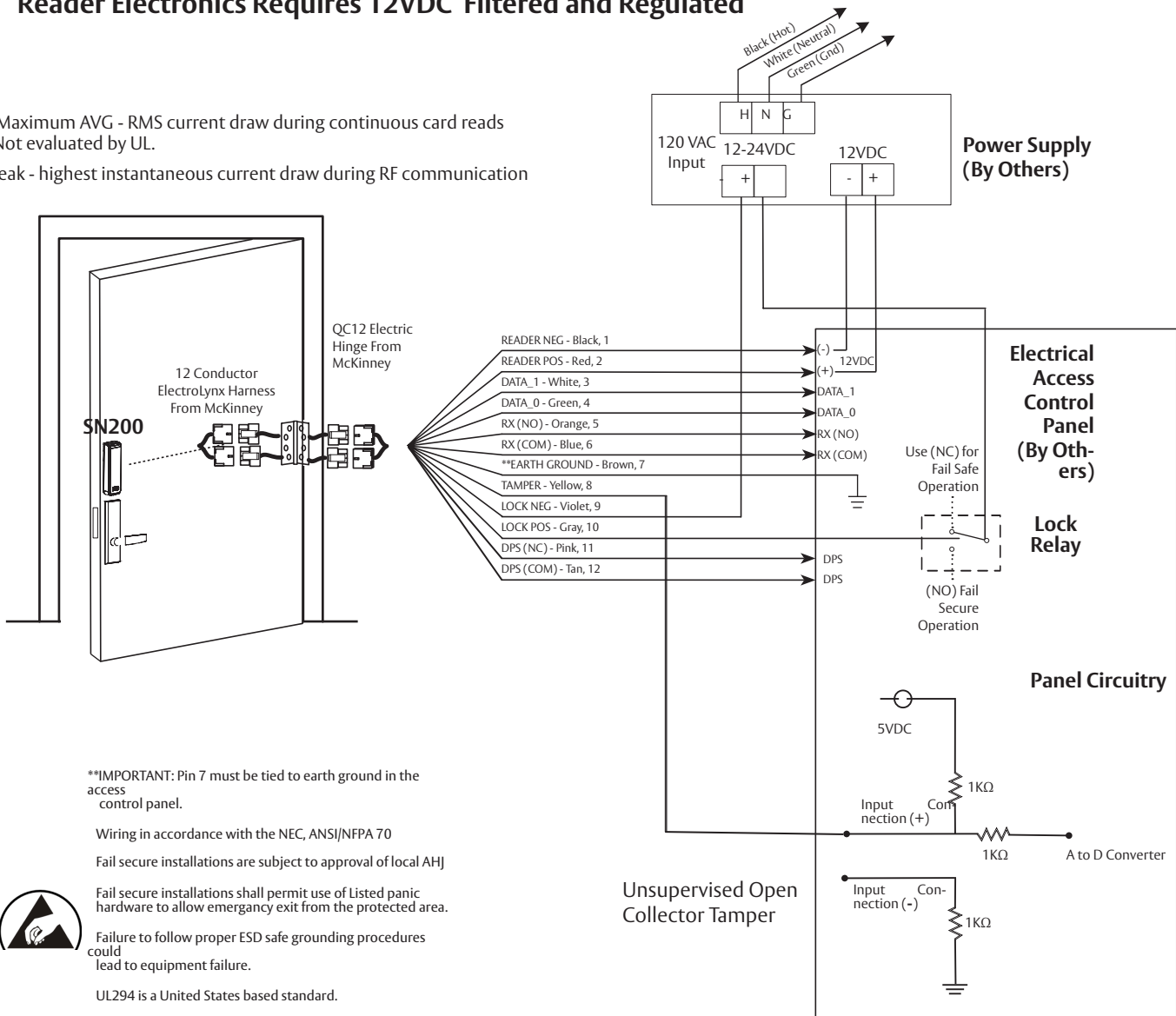

****IMPORTANT:** Pin 7 must be tied to earth ground in the access control panel.

Wiring in accordance with the NEC, ANSI/NFPA 70

Fail secure installations are subject to approval of local AHJ

Fail secure installations shall permit use of Listed panic hardware to allow emergency exit from the protected area.

Failure to follow proper ESD safe grounding procedures could lead to equipment failure.

UL294 is a United States based standard.



Copyright © 2020-2023 Sargent Manufacturing Company, an ASSA ABLOY Group company. All rights reserved. Reproductions in whole or in part without express written permission of Sargent Manufacturing Company is prohibited.

01/31/23

Wiring Diagrams (Continued)

SN210 OSDP (56- ELR) Application Diagram #3 (12/24VDC System)

	12V		24V	
	Average	Peak	Average	Peak
Reader**	75mA	250mA	n/a	n/a
Actuator	15mA	500mA	15mA	500mA
56-ELR	n/a	n/a	250mA dogged	1A inrush during retraction

**Maximum AVG - RMS current draw during continuous card reads
Not evaluated by UL

Peak - highest instantaneous current draw during RF communication

OSDP Operation Mode*:

*LED/Sounder control and Tamper status communicated over OSDP serial protocol

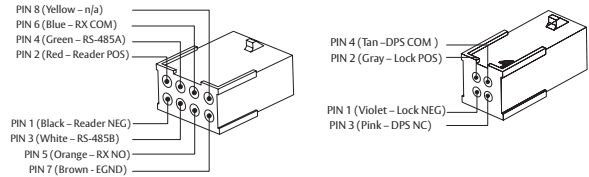

Reader Electronics Requires 12VDC Filtered and Regulated

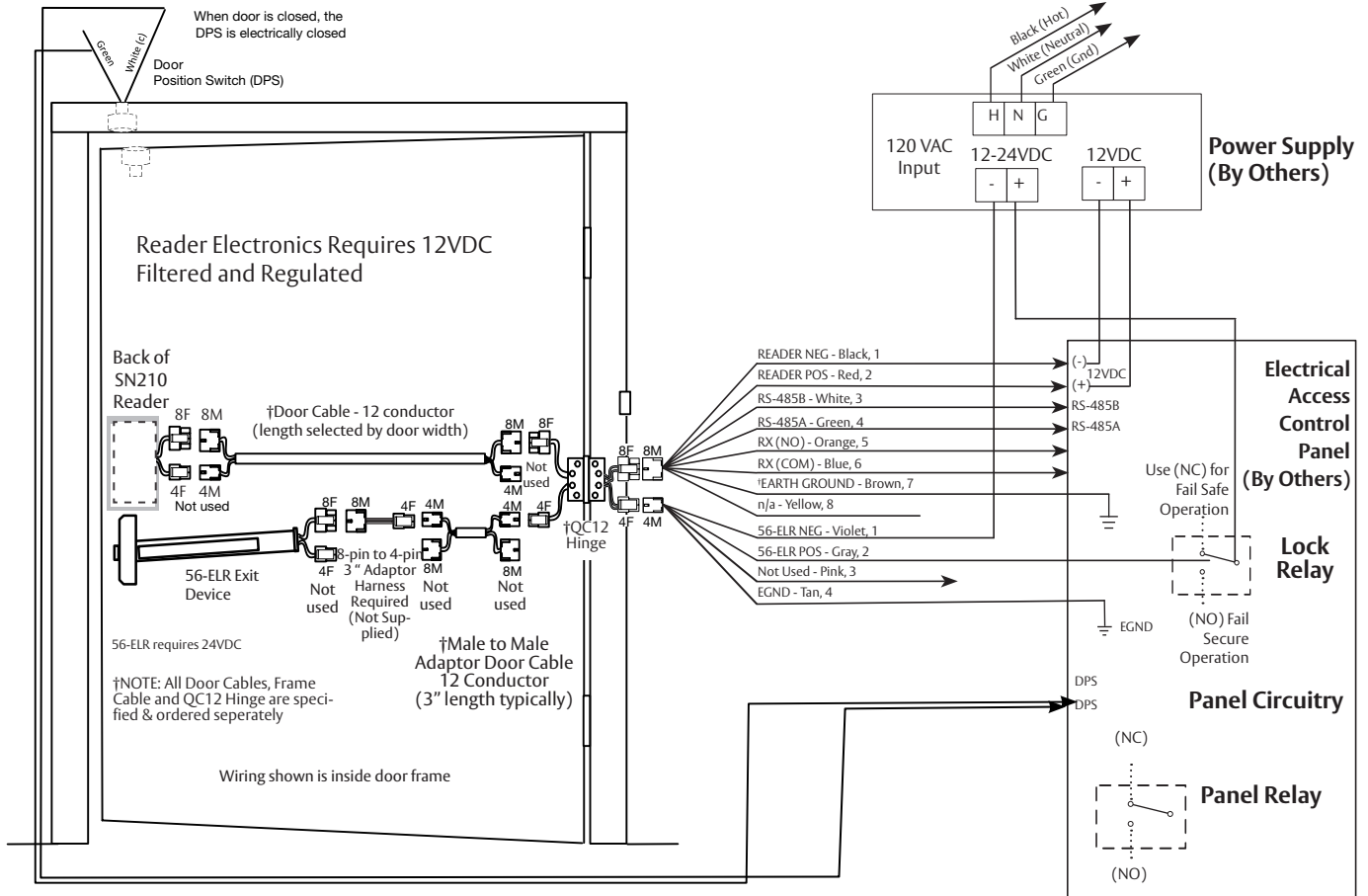

†IMPORTANT: Pin 7 must be tied to earth ground in the access control panel.

Wiring in accordance with the NEC, ANSI/NFPA 70

Fail secure installations are subject to approval of local AHJ

Fail secure installations shall permit use of Listed panic hardware to allow emergency exit from the protected area.

Failure to follow proper ESD safe grounding procedures could lead to equipment failure.



5 Installation Instructions

Parts Breakdown (PE)8600 Concealed Vertical Rod (CVR) Exit Device

Left Hand Reverse Door Shown

Tools Required:

- #2 Phillips screwdriver
- Push pin (provided)
- T10 Torx Driver
- 3/32" drill bit
- 3/4" drill bit
- 5/16" drill bit
- 3/8" drill bit
- 7/16" drill bit
- 1" bore
- 2-1/8" bore

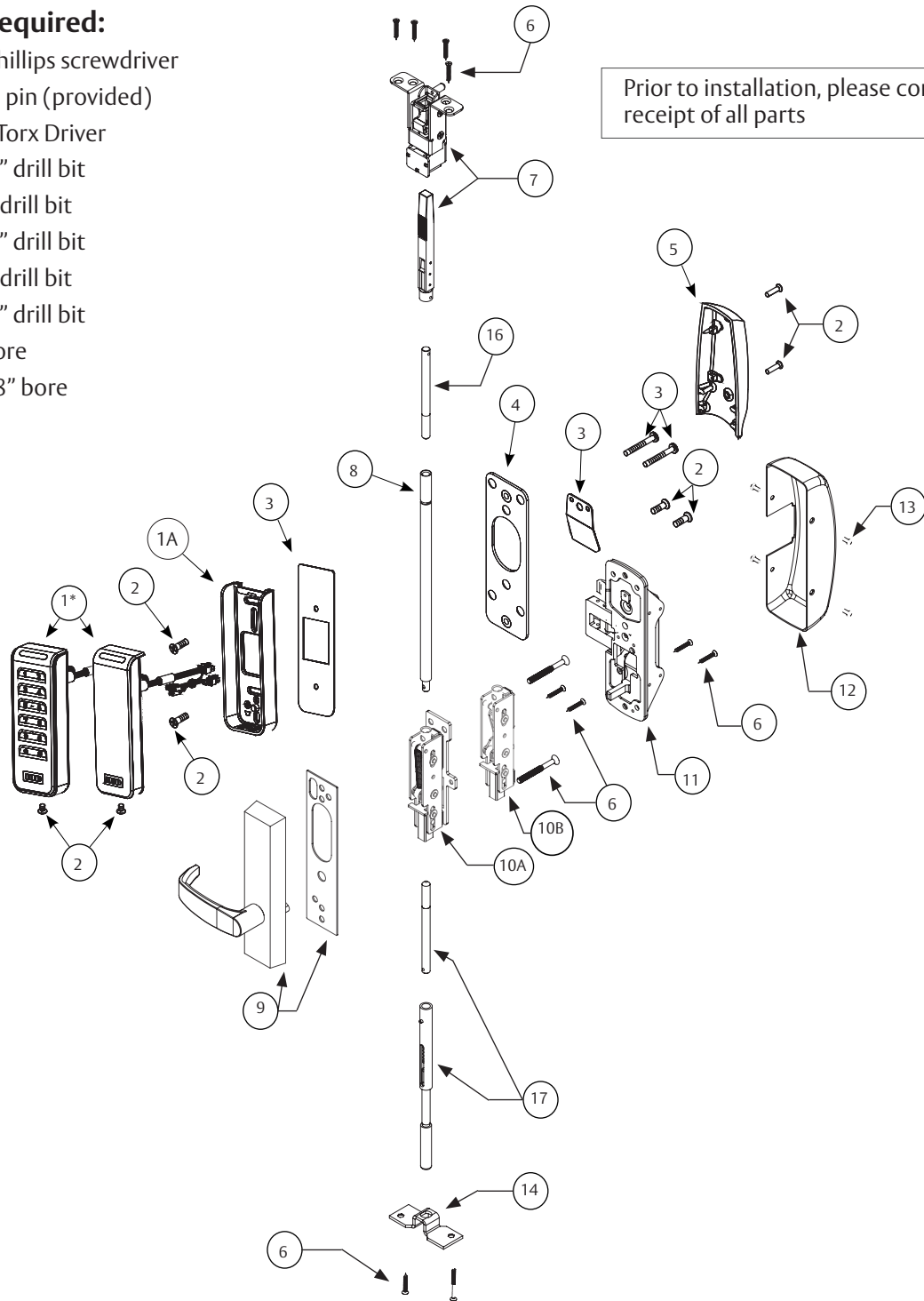

Copyright © 2020-2023 Sargent Manufacturing Company, an ASSA ABLOY Group company. All rights reserved. Reproductions in whole or in part without express written permission of Sargent Manufacturing Company is prohibited.

01/31/23

5

Installation Instructions SN200/210 (PE)8600
Concealed Vertical Rod (CVR) Exit Device

Parts Breakdown (PE)8600 (Continued)

ITEM	Description	Req.
1	Reader & Harness Assembly	1
1A	Signo Reader Back Plate	1
2	Back Plate Mounting Screw Pack - (2) #8 x 5/8" Phillips flat head self-drilling screws	1
3	SN200/210 Standard Fire Kit	1
4	Inside Mounting Plate	1
5	Inside Escutcheon	1
6	Chassis Wood Door (WD) Screw Pack	1
	Chassis Metal Door (MD) Screw Pack (not shown)	
7	WD (PE)8600 Top Assembly	1
	MD/AD (PE)8600 Top Assembly (not shown)	
8	Aux Control Rod Adapter	1
9*	Trim (Trim with gasket shown)*	
10A	WD Inner Case Assembly	1
10B	MD/AD Inner Case Assembly	1
11	(PE)8600 Chassis LHRB	1
	(PE)8600 Chassis RHRB (not shown)	
12	Chassis Cover	1
13	Rail and Chassis Cover Screw Pack- (4) #8-32 x 5/16 oval head machine screws	1
14	MD/WD Bottom Case	1
	AD Bottom Case (not shown)	1

*For other outside trim and their part numbers, consult factory.

Copyright © 2020-2023 Sargent Manufacturing Company, an ASSA ABLOY Group company. All rights reserved. Reproductions in whole or in part without express written permission of Sargent Manufacturing Company is prohibited.

01/31/23

5

Installation Instructions SN200/210 (PE)8600 Concealed Vertical Rod (CVR) Exit Device (Continued)

1 Door Preparation

A. Verify Hand and Bevel of Door

- Check hand of door. Exit Device may be handed.
- Door should be fitted and hung.
- Verify box label for size of exit device, function and hand.

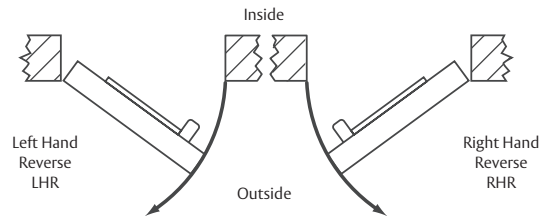

Fig. 1A

B. Door Preparation

Prepare door according to appropriate template. If necessary, refer to website www.intelligentopenings.com.

Prior to installation, make sure all holes are free of burrs, debris and sharp edges.

If doors are not properly reinforced per ANSI 115.2, commercially available reinforcements should be installed.

Templates:

- Field Template (ships with product): **A8129** or **MEFT12** (for PE Series)
- Door Manufacturer's Template: **4704** or **MEDT34** (for PE Series)

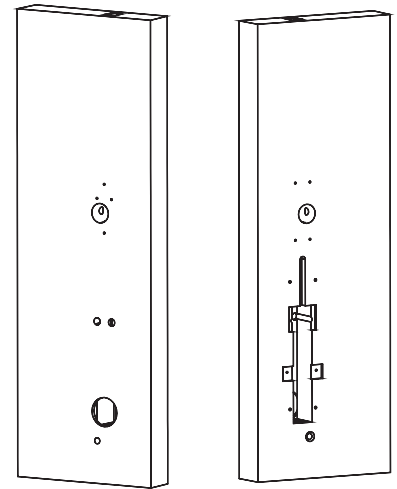

Fig. 1B

2 Concealed Door Position Switch (3287) Instructions

Use SARGENT 3287 Concealed Door Position Switch with this SN200/210 product.

1. Install the 3287 Concealed Door Position Switch described in SARGENT document **A7448**.
2. Wire the 3287 Concealed Door Position Switch to the EAC door position Input.
3. Connect the common wire of the switch to the common input terminal of the EAC; and the normally open wire of the switch to the normally open input terminal of the EAC.

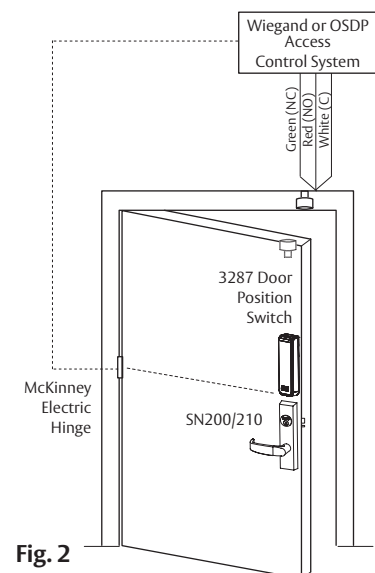

Fig. 2

Copyright © 2020-2023 Sargent Manufacturing Company, an ASSA ABLOY Group company. All rights reserved. Reproductions in whole or in part without express written permission of Sargent Manufacturing Company is prohibited.

01/31/23

3 Install Inner Case Assembly

A. Wood Door (WD)

1. Install the inner case assembly with (2) #12 x 1" Phillips flat-head screw (Fig. 3A).

B. Metal Door (MD/AD)

1. Assemble rods to inner case.
2. Slide rod assembly into door and secure with #10-24 x 3/8" screw for top inner case assembly and #10-24 x 1/2" screw for bottom inner case assembly (Fig. 3B).

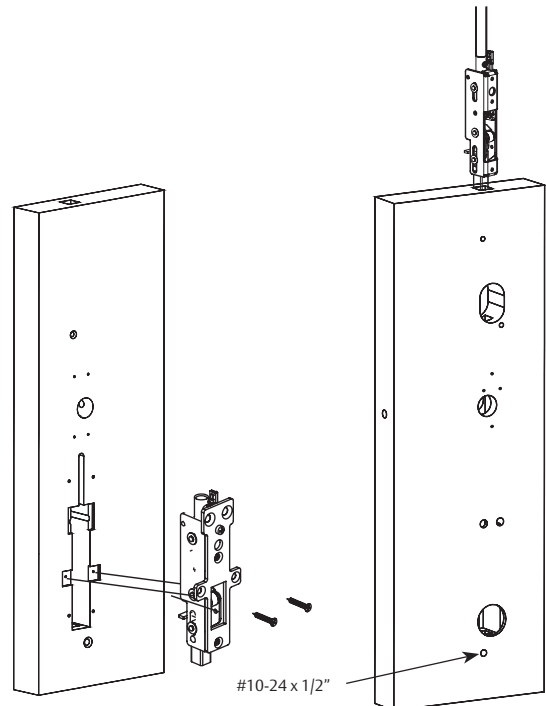

Fig. 3A

Fig. 3B

4 Install Outside Exit Trim and Chassis

A. Outside Trim

Line exit trim and gasket (if required) up with through-holes:

1. For exterior application, use trim gasket to seal between trim escutcheon and outside door surface.
NOTE: For 56- ELR install, skip Step 2.
2. For wood doors: Route trim wire harness connector through the cylinder hole, up and through the wire run channel to the controller cutout.
3. For metal doors: Route trim wire harness through the cylinder hole in the controller cutout.
4. Trim spindle will engage the hub of chassis.

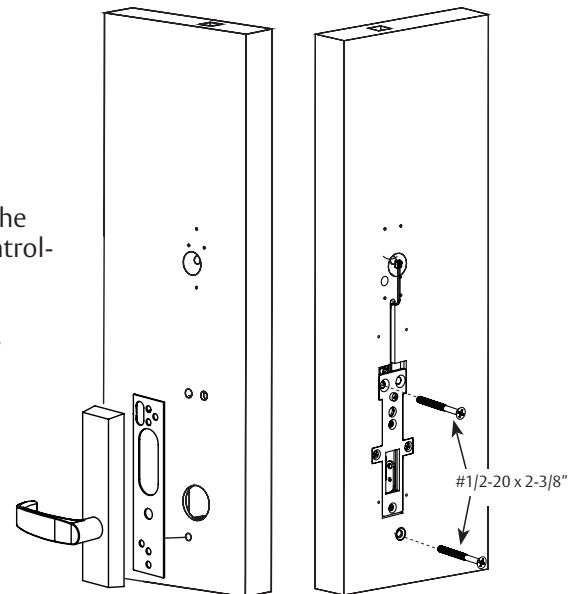

Fig. 4A

Fig. 4B

4 Install Outside Exit Trim and Chassis (Continued)

B. Chassis

1. Position chassis carefully onto the inner case assembly from the inside of the door. Feed wires up through routed channel (Fig. 4C).
Note: Keep wires in routed channel.
DO NOT pinch.
2. Fasten the chassis to door using (4) #12 x 1" Phillips flathead screws (Fig. 4C).

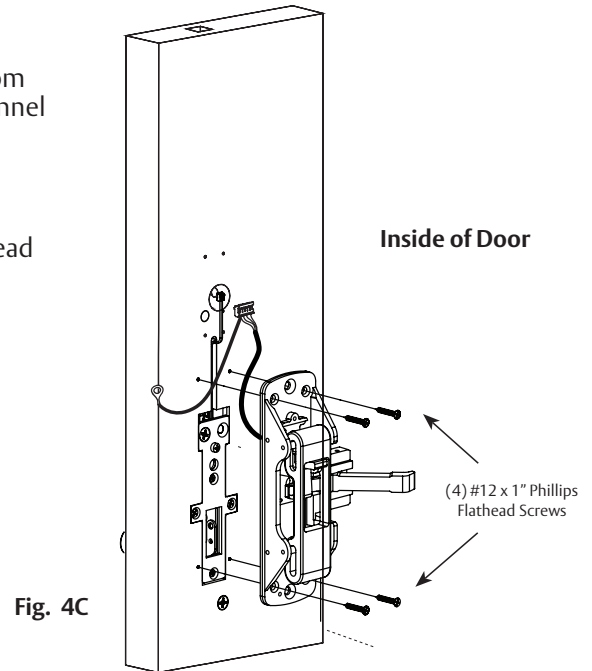

5 Install Reader Backplate and (Optional*) Fire Shield

1. For fire-rated doors only, install reader backplate and fire shield to door using two (2) #8-18 x 5/8" Phillips flat head self-drilling screws (Fig. 5).
2. For exterior doors, install reader backplate using two (2) #8-18 x 5/8" Phillips flat head self-drilling screws (Fig. 5).
3. *For non-fire rated interior doors, no fire shield is required; simply install backplate using two (2) #8-18 x 5/8" Phillips flat head self-drilling screws.

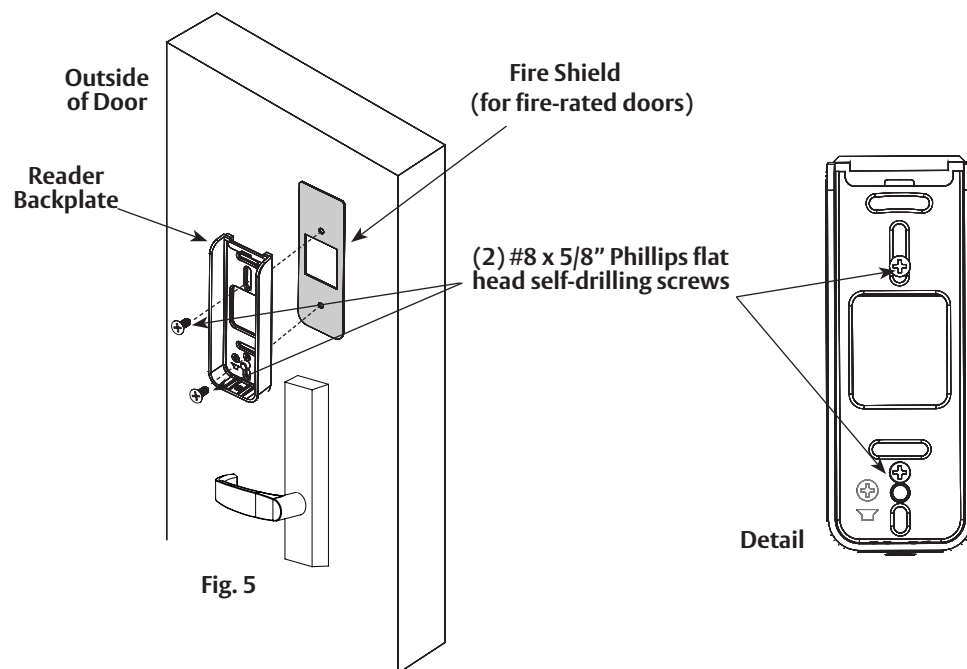

6 Installation of SN200/210 Reader



Observe precautions for handling electrostatic sensitive devices.

1. Feed reader harness through door (Fig. 6A).
2. Hook the top of the reader on the top of the mounting plate (Fig. 6B).
3. Align the bottom of the reader with the bottom of the mounting plate.
4. Secure the reader to the mounting plate using the supplied 6-32 x 3/8" T10 security Torx machine screw (Fig. 6C).

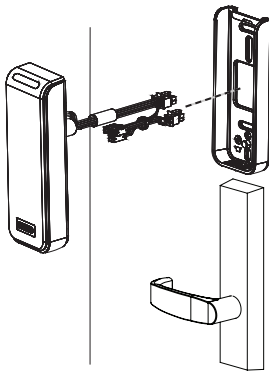

Fig. 6A

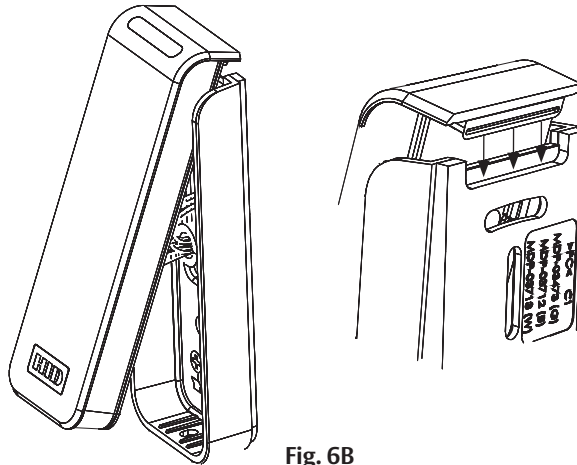
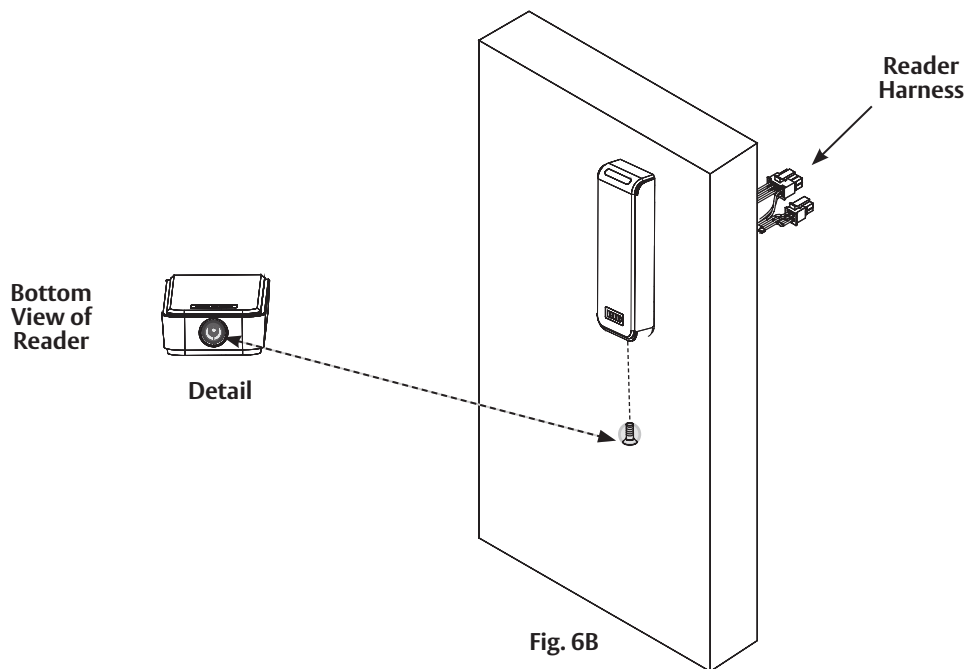

Fig. 6B



7 Inside Mounting Plate and Wire Connections

NOTE: Feed door harness through hole in mounting plate.

1. Attach the mounting plate using two (2) #8 x 1/2" lower screws (Fig. 7A).
Feed bottom left screw through green/yellow ground wire ring terminal. Install screw. Ensure that green/yellow wire points toward top of door in order to avoid interference with escutcheon.
2. If fire kit is not being used, install (2) #8 x 1/2" in upper mounting plate holes.
3. Connect 6-pin connector from lock body to P3 (6-pin) on reader harness.
4. Carefully tuck ElectroLynx connectors into 1 inch hole in door (Fig. 7E).

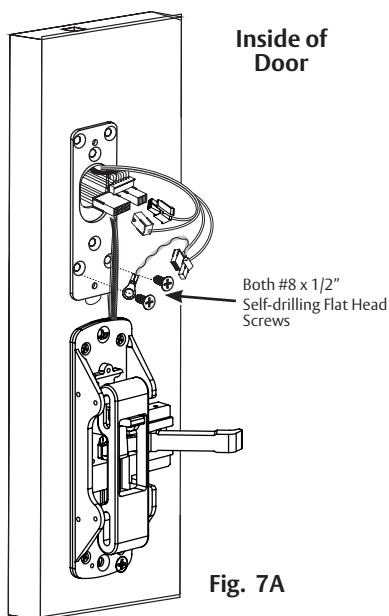

Fig. 7A

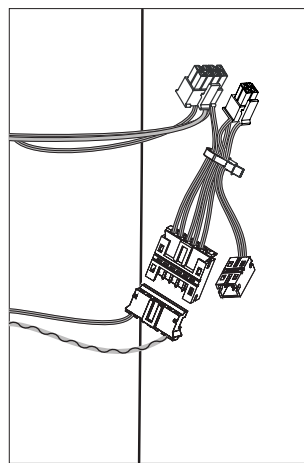

Fig. 7B

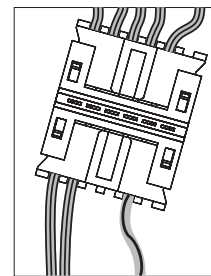

Fig. 7C

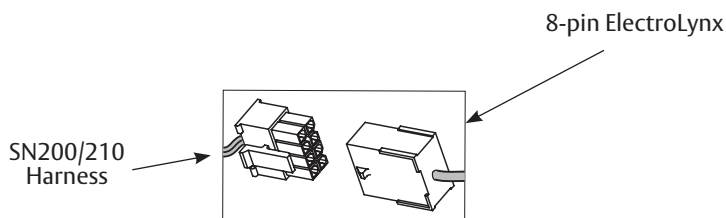

Fig. 7D



Fig. 7E

NOTE: Neatly fold excess wires into remaining space to prevent pinching wires when mounting inside escutcheon (Fig. 7E).

8 Fire Plate Installation and Earth Ground Connection

1. Fasten plate with two (2) #8 x 1 1/4" Phillips pan head self-drilling screws.

Note: For non-fire rated doors, omit fire plate.

Inside of
Door

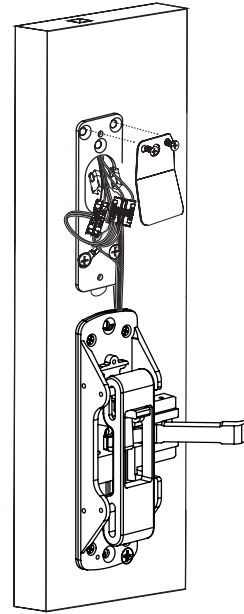

Fig. 8

9 Install Rail Assembly

1. Retrieve Request To Exit (REX) harness from end of rail. Harness has limited travel and can be damaged.
2. Attach harness to female connector on chassis.
3. Install rail and screws per exit device instructions.

Note: This view shows rim exit device version.

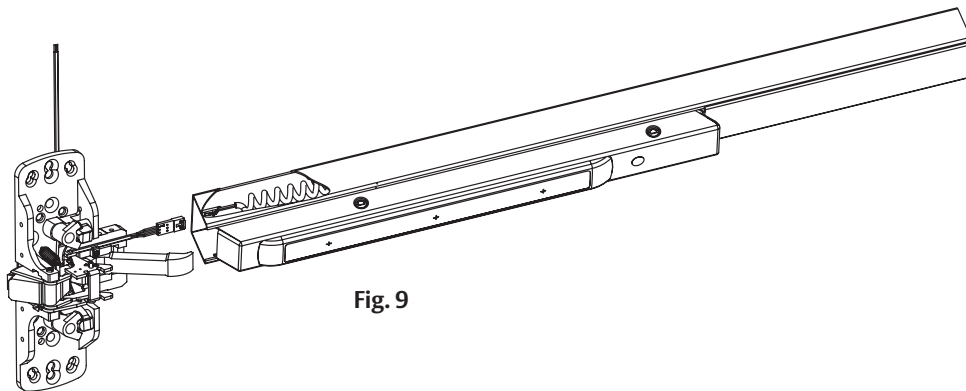

Fig. 9

10 Install Chassis and Inside Escutcheon

1. Secure chassis cover to chassis using (4) #8-32 x 5/16 oval head machine screws, Fig. 10A.
2. Carefully and neatly fold lock body wires onto themselves. ElectroLynx connectors should be positioned side-by-side under the fire block plate. Lock body connectors should be positioned side-by-side on top of the ElectroLynx connectors.
3. Position inside escutcheon in order to ensure wires are not pinched. Adjust wires as necessary to ensure they are clear of rear escutcheon. Seat inside escutcheon against door.
Note: Be sure to cover, but not pinch wires when mounting escutcheon.
4. Insert (2) #8-32 x 5/8" Phillips flat head escutcheon screws and thread into mounting plate, Fig 10B.

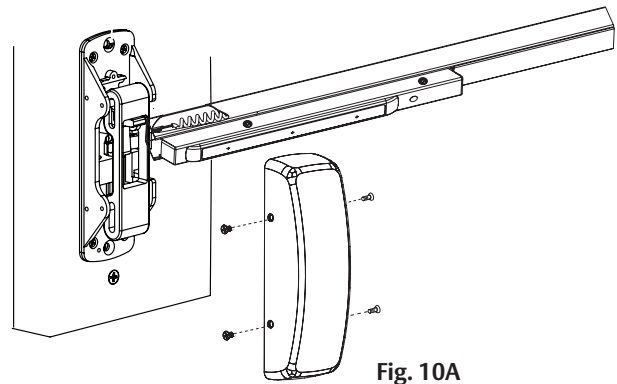

Fig. 10A

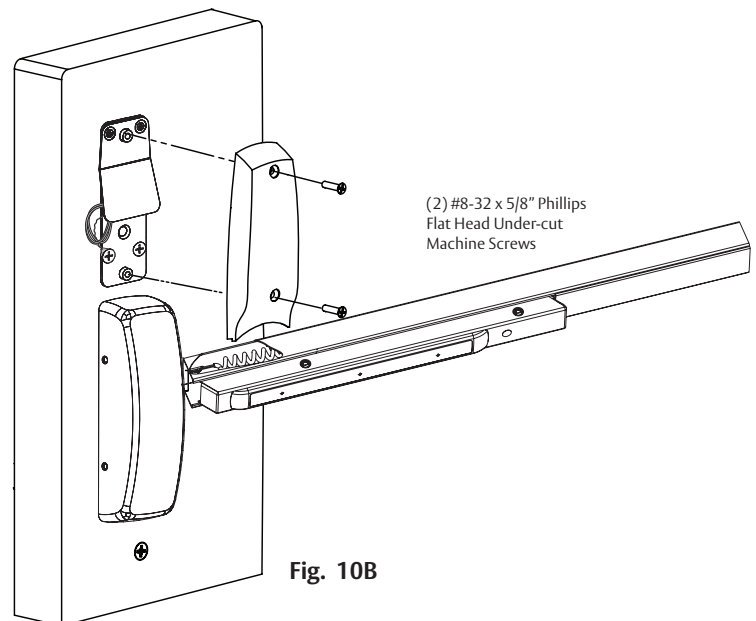

Fig. 10B

>>If you are installing 56- ELR Exit Device <<
Continue to Section 10 Operational Check

6

Installation Instructions SN200/210 (PE)8700 Surface Vertical Rod (SVR) Exit Device

Parts Breakdown

Left Hand Reverse Door Shown

Tools Required:

- #2 Phillips screwdriver
- Push pin (provided)
- T10 Torx Driver
- 3/32" drill bit
- 3/4" drill bit
- 5/16" drill bit
- 3/8" drill bit
- 7/16" drill bit
- 1" bore
- 2-1/8" bore

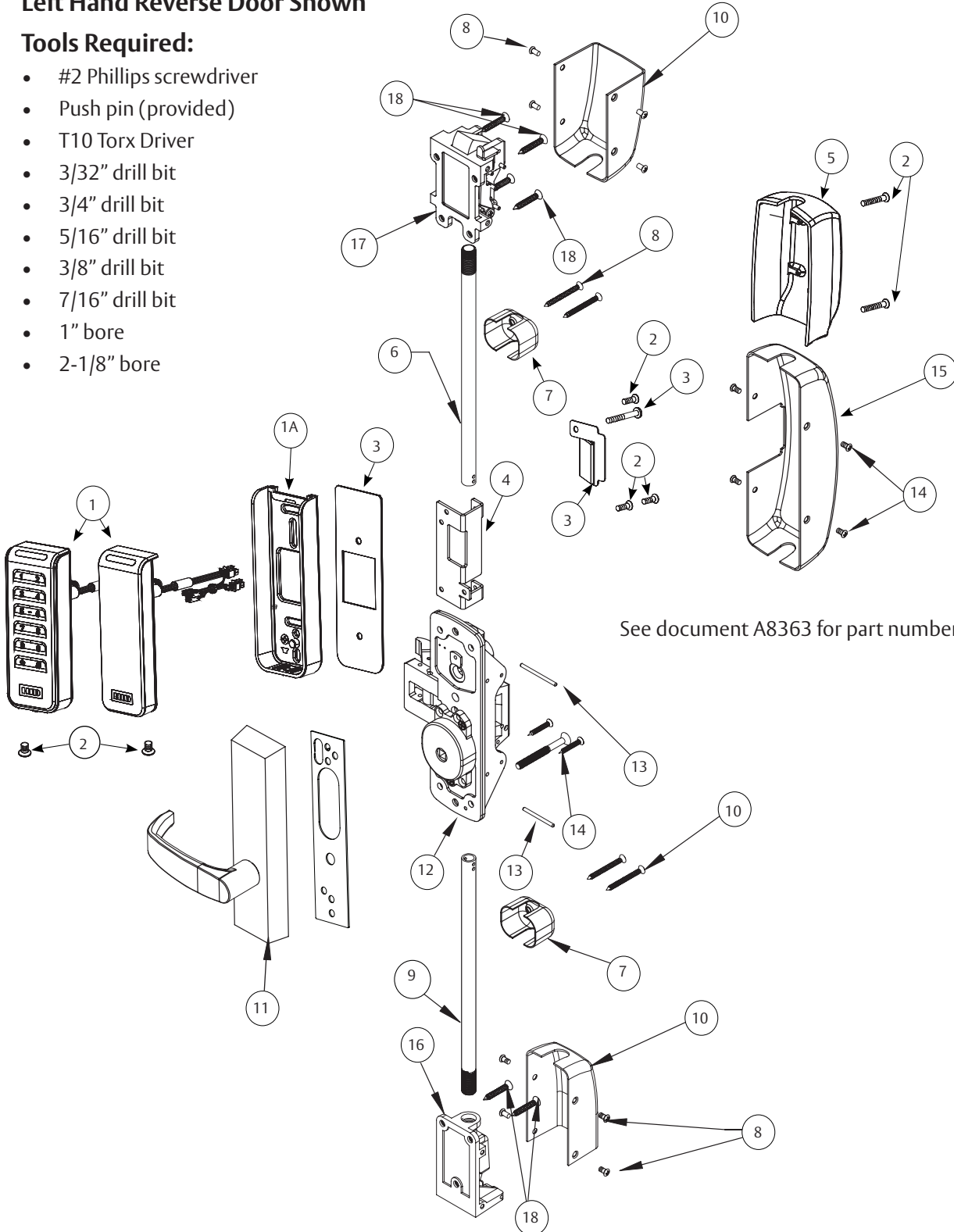

See document A8363 for part numbers

Parts Breakdown (PE)8700 (Continued)

1	SN200/210 Reader & Harness Assembly	1
1A	Signo Reader Back Plate	1
2	Screw Pack	1
3	SN200/210 (PE)8700 Standard Fire Kit	1
4	Mounting Bracket	1
5	Inside Escutcheon	1
6	Top Rod (consult factory)	1
7	Guide for Rod	2
8	Screw Pack for Guide and Covers	2
9	Bottom Rod (consult factory)	1
10	Case Assembly Cover	2
11	Trim (Trim with gasket shown)	1
12	NB Chassis Assembly (LHRB)	1
	NB Chassis Assembly (RHRB)	
	Chassis Assembly LHRB	
	Chassis Assembly RHRB	
13	Rod Adjustment Pin	2
14	Screw Pack "B"	1
	Screw Pack "A"	
15	Chassis Cover	1
16	Bottom Case Assembly	1
17	Top Case Assembly	1
18	Screw Pack (Top and Bottom Cases)	1

See document A8363 for part numbers

6

Installation Instructions SN200/210 (PE)8700 Surface Vertical Rod (SVR) Exit Device (Continued)

1 Door Preparation

A. Verify Hand and Bevel of Door

- Check hand of door. Exit Device may be handed.
- Door should be fitted and hung.
- Verify box label for size of exit device, function and hand.

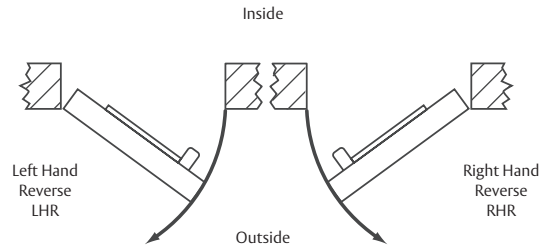

Fig. 1A

B. Door Preparation

Prepare door according to appropriate template. If necessary, refer to website, www.intelligentopenings.com:

- Prior to installation, make sure all holes are free of burrs, debris, and sharp edges.
- If doors are not properly reinforced per ANSI 115.2, commercially available reinforcements should be installed.

Templates:

- Field Template (ships with product): A8125 or MEFT8 (for PE Series), A8126, A8129 or MEFT12 (for PE Series)
- Door Manufacturer's Template: 4705 or MEFT55 (for PE Series)

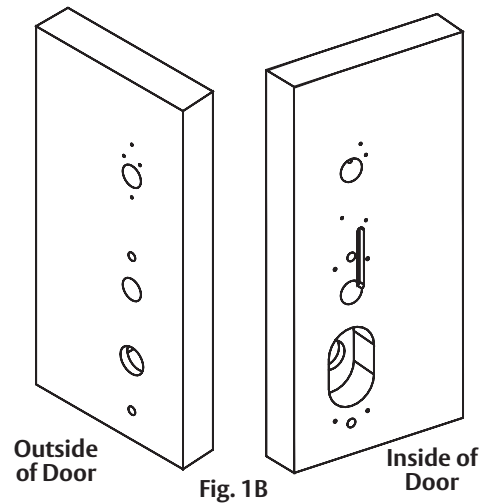

Fig. 1B

2 Concealed Door Position Switch (3287) Instructions

Use SARGENT 3287 Concealed Door Position Switch with this SN200/210/S product.

1. Install the 3287 Concealed Door Position Switch described in SARGENT document A7448.
2. Wire the 3287 Concealed Door Position Switch to the EAC door position Input.
3. Connect the common wire of the switch to the common input terminal of the EAC; and the normally open wire of the switch to the normally open input terminal of the EAC.

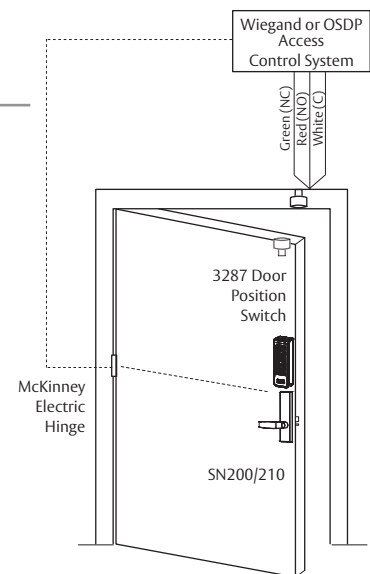

Fig. 2

3 Install Outside Trim and Exit Chassis

Line exit trim and gasket (if required) up with through-holes:

1. For exterior application, use trim gasket to seal between trim escutcheon and outside door surface.
NOTE: For 56- ELR install, skip Step 2
2. For wood doors: Route trim wire harness connector through the cylinder hole, up and through the wire run channel to the controller cutout.

For metal doors: Route trim wire harness through the cylinder hole out the controller cutout.

3. Trim spindle will engage the hub of chassis.

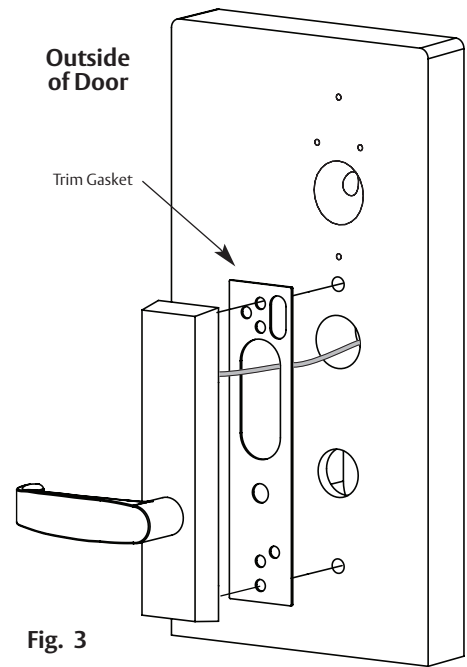

Fig. 3

4 Install Exit Chassis and

1. Position chassis carefully onto the inner case assembly from the inside of the door.
Feed wires up through the routed channel as shown (Fig.4A).

Note: Keep wires in routed channel. DO NOT pinch.

2. Mount chassis to trim using (2) # 1/4 -20 x 2-3/8" flat head machine screws.

3. Fasten the chassis to door using either:

- (4) #10 wood screws for wood doors (or)
- (4) #10-24 x 3/4" machine screws for metal doors

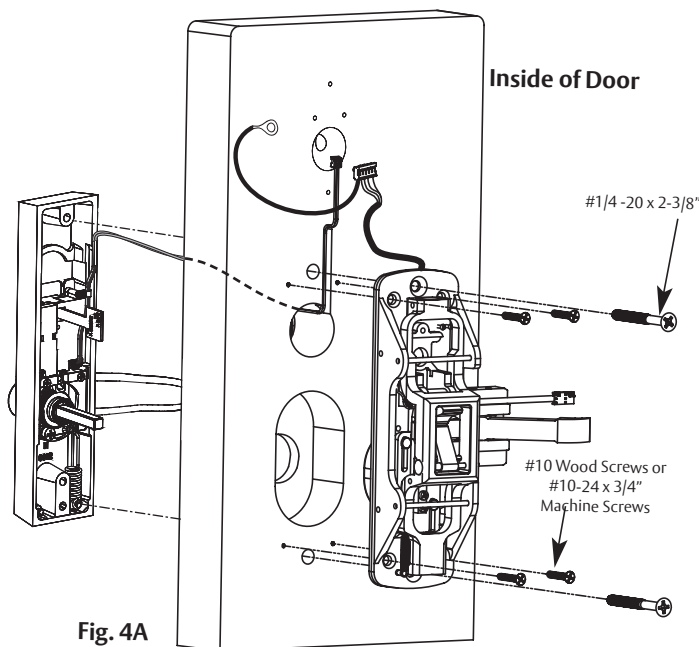
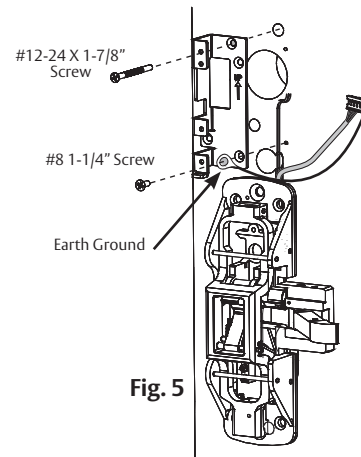

Fig. 4A

5 Install Mounting Bracket and Earth Ground Connection

1. Secure mounting bracket to inside of door using (1) #12-24 x 1-7/8 inch screw (Fig. 5).
2. Attach the green/yellow wire ring terminal using (1) #8 1 1/4" Phillips pan head self-drilling screw to the lower right mounting plate screw (Fig.5).



6 Fire Plate Installation* (Optional) and Earth Ground Connection

1. Fasten the plate with (1) #8 1 1/4" Phillips pan head self-drilling screw.

*Note: For non-fire rated doors, omit the fire plate.

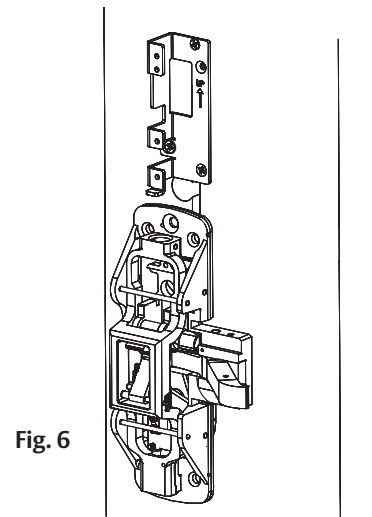

7 Install Reader Backplate and (Optional*) Fire Shield

1. Attach backplate using (2) #8 x 5/8" self-drilling screws (Fig. 7).

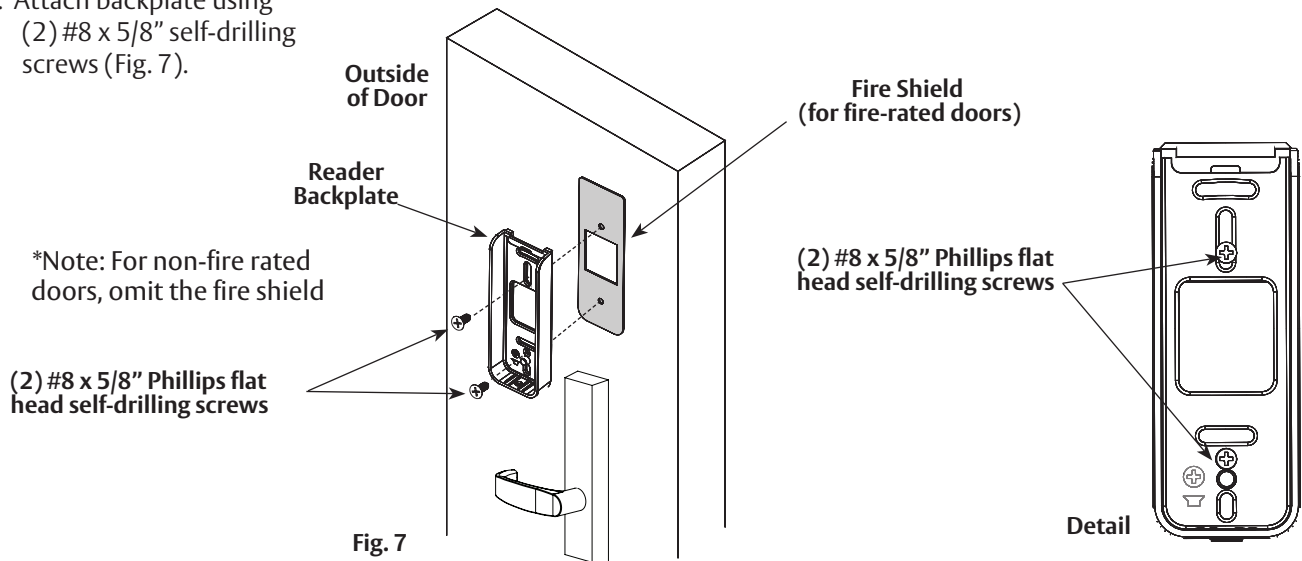

8 Installation of SN200/210 Reader



Observe precautions for handling electrostatic sensitive devices.

1. Feed reader harness through door (Fig. 8A).
2. Hook the top of the reader on the top of the mounting plate (Fig. 8B).
3. Align the bottom of the reader with the bottom of the mounting plate.
4. Secure the reader to the mounting plate using (supplied) 6-32 x 3/8" T10 security Torx machine screw (Fig. 8B).

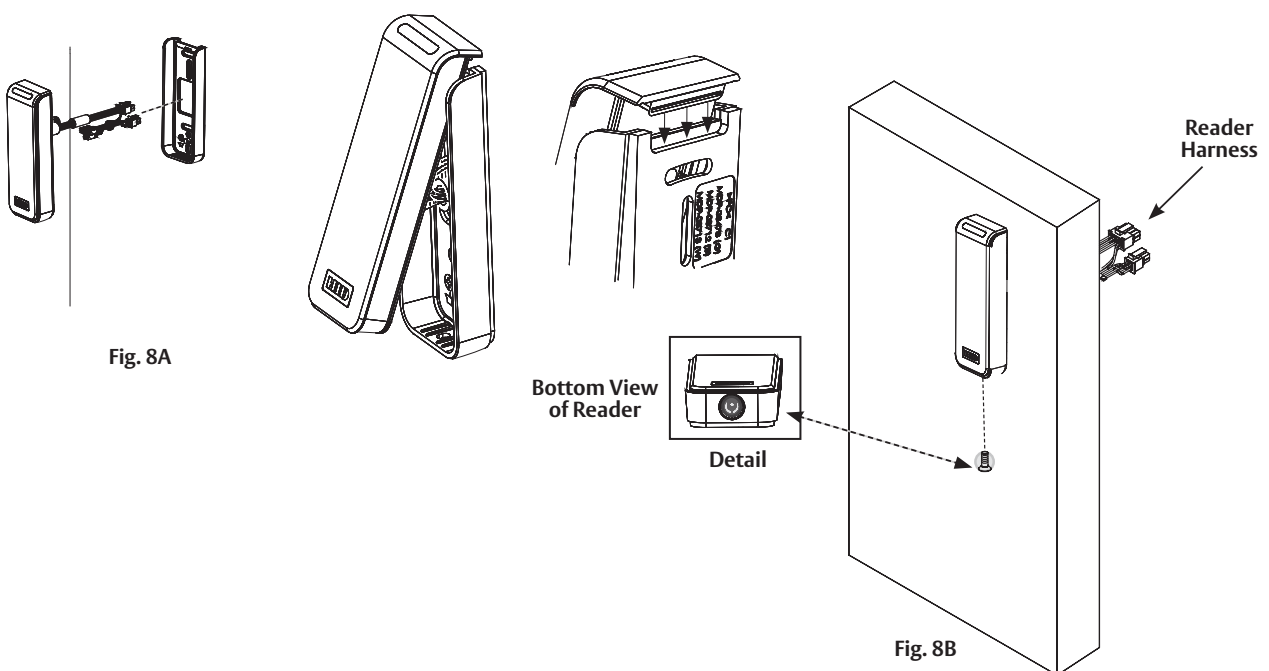

9 Installation of Rail Assembly

1. Retrieve Request To Exit (REX) harness from end of rail. Harness has limited travel and can be damaged.
2. Attach harness to female connector on chassis.
3. Install rail and screws per exit device instructions.

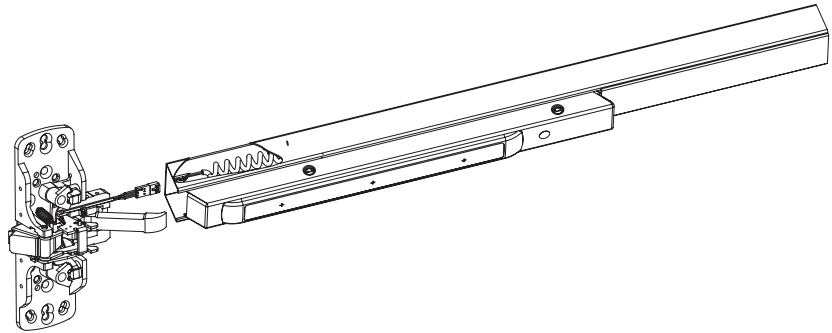

Fig. 9

10 Install Chassis Cover and Inside Escutcheon

1. Secure chassis cover to chassis using (4) #8-32 x 5/16 oval head machine screws (Fig. 10A).
2. Position inside gasket and escutcheon against door. Verify that no wires are being pinched.
3. Mount inside escutcheon assembly to plate using (2) #8-32 x 7/8" Phillips flat head undercut machine screws (Fig. 10B).

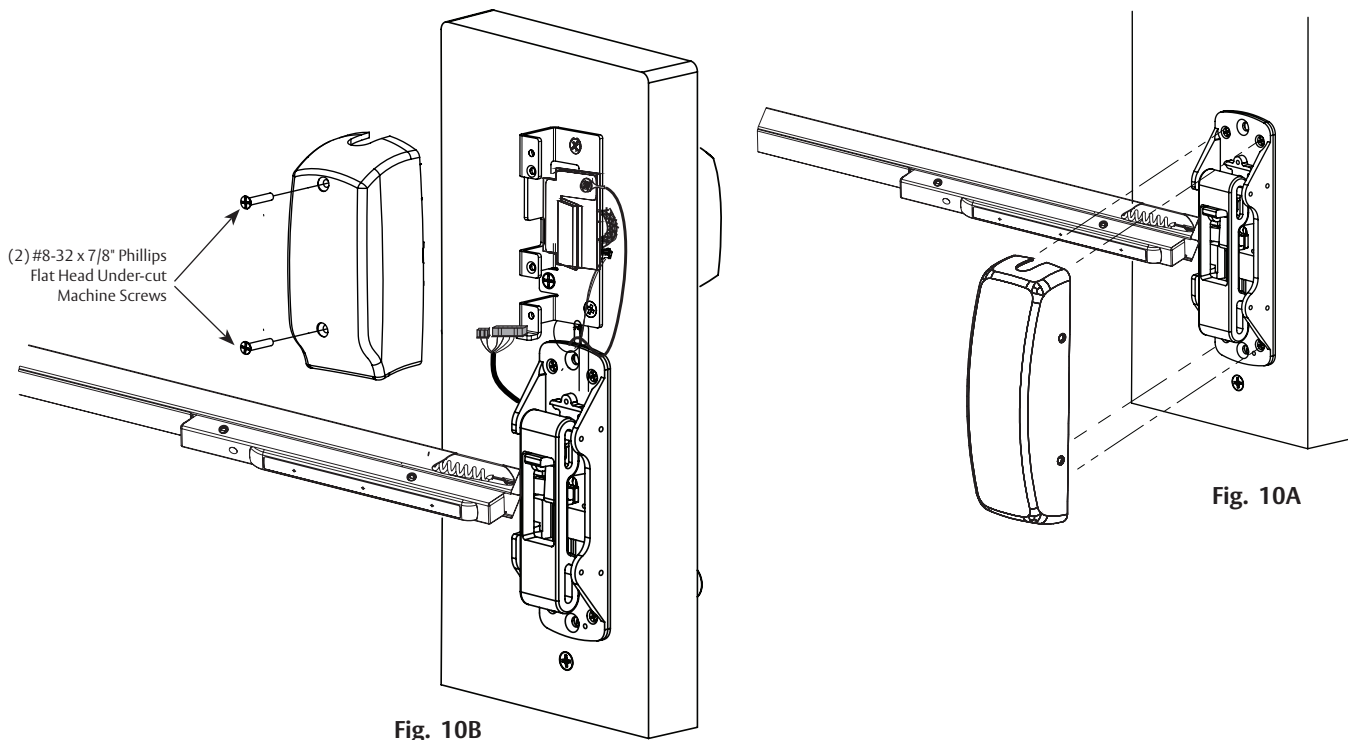

Fig. 10A

Fig. 10B

>>If you are installing 56- ELR Exit Device <<
Continue to Section 10 Exit Device Controller Configuration Check

7 Installation Instructions SN200/210 8877/8878 Rim Exit Device

Parts Breakdown

Tools Required:

- #2 Phillips screwdriver
- Push pin (provided)
- T10 Torx Driver
- 3/32" drill bit
- 3/4" drill bit
- 5/16" drill bit
- 3/8" drill bit
- 7/16" drill bit
- 1" bore
- 2-1/8" bore

Left Hand Reverse Door Shown

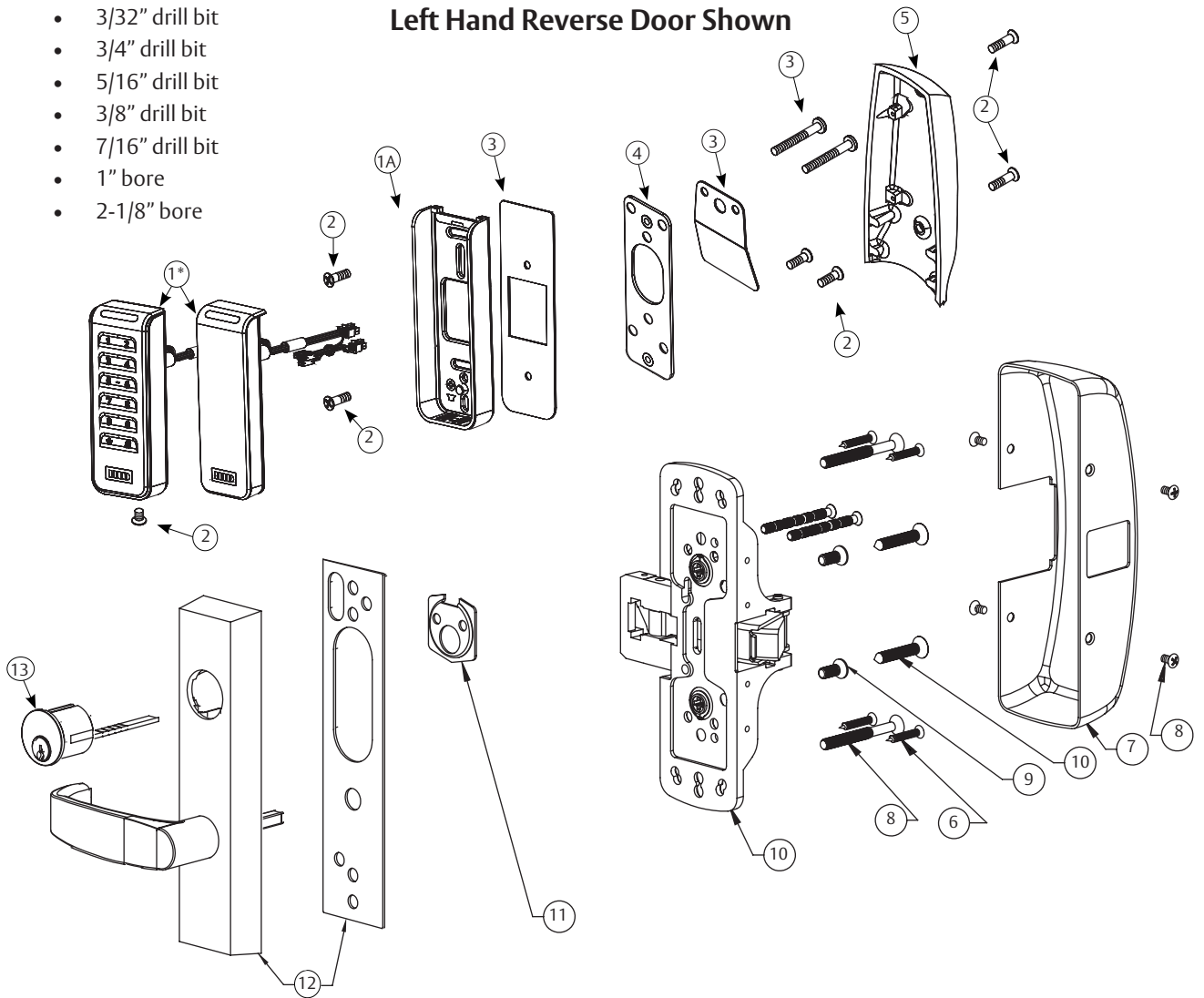

See document A8363 for part numbers

Copyright © 2020-2023 Sargent Manufacturing Company, an ASSA ABLOY Group company. All rights reserved. Reproductions in whole or in part without express written permission of Sargent Manufacturing Company is prohibited.

01/31/23

Parts Breakdown (PE)8800 (Continued)

ITEM	Description	Req.
1	SN200/210 Reader & Harness Assembly	1
1A	Signo Reader Back Plate	1
2	Screw Pack	1
3	SN200/210 Standard Fire Kit	1
4	Inside Mounting Plate	1
5	Inside Escutcheon	1
6	Screw Pack (Rail and Chassis Cover)	1
7	Chassis Cover	1
8	Screw Pack (Chassis)	1
9	Cylinder Connecting Screws	2
10	(PE)8800 Chassis Assembly	1
11	Cylinder back Plate (Used with non-Sargent Cylinders)	1
12	Trim (Trim with gasket shown)	1
13	Reference SN200/210 Catalog for Available Cylinders	1
14	DPS Door Position Switch (not shown)	1

See document A8363 for part numbers

7 Installation Instructions 8877/8878 Rim Exit Device (Continued)

1 Door Preparation

A. Verify Hand and Bevel of Door

- Check hand of door. Exit Device may be handed.
- Door should be fitted and hung.
- Verify box label for size of exit device, function and hand.

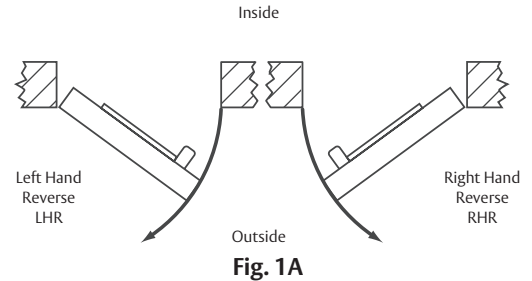

B. Door Preparation

Prepare door according to appropriate template. If necessary, refer to website, www.intelligentopenings.com:

- Prior to installation, make sure all holes are free of burrs, debris and sharp edges.
- If doors are not properly reinforced per ANSI 115.2, commercially available reinforcements should be installed.

Templates:

- Field Template (shipped with product): A8127 or MEFT15 (for PE Series) and A8129 or MEFT12 (for PE Series).
- Door Manufacturer’s Template: 4707 or MEDT56.

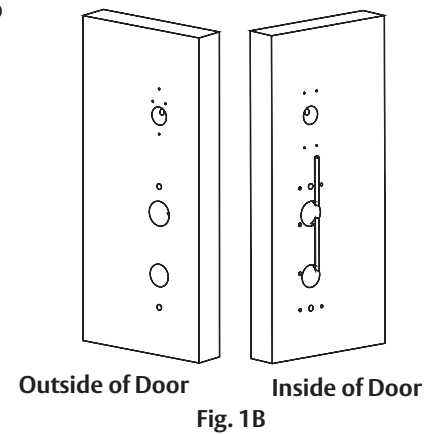

2 Concealed Door Position Switch (3287) Instructions

1. Install the 3287 Concealed Door Position Switch described in SARGENT document A7448.
2. Wire the 3287 Concealed Door Position Switch to the EAC door position Input.
3. Connect the common wire of the switch to the common input terminal of the EAC; and the normally open wire of the switch to the normally open input terminal of the EAC.

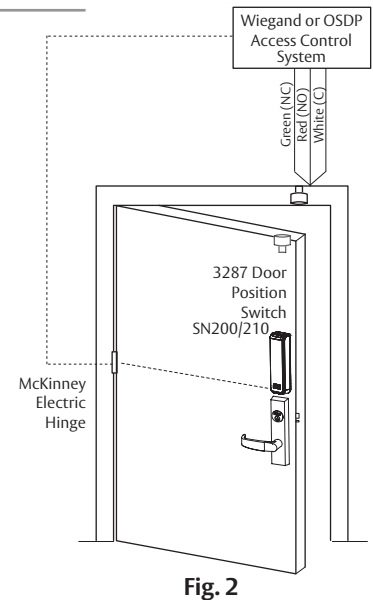

Copyright © 2020-2023 Sargent Manufacturing Company, an ASSA ABLOY Group company. All rights reserved. Reproductions in whole or in part without express written permission of Sargent Manufacturing Company is prohibited.

01/31/23

3 Install Outside Trim

Line exit trim and gasket (if required) up with through-holes:

1. For exterior application, use trim gasket to seal between trim escutcheon and outside door surface.
NOTE: For 56- ELR install, skip Step 2.
2. For wood doors: Route trim wire harness connector through the cylinder hole, up and through the wire run channel to the controller cutout.

For metal doors: Route trim wire harness through the cylinder hole out the controller cutout.

3. Trim spindle will engage the hub of chassis.

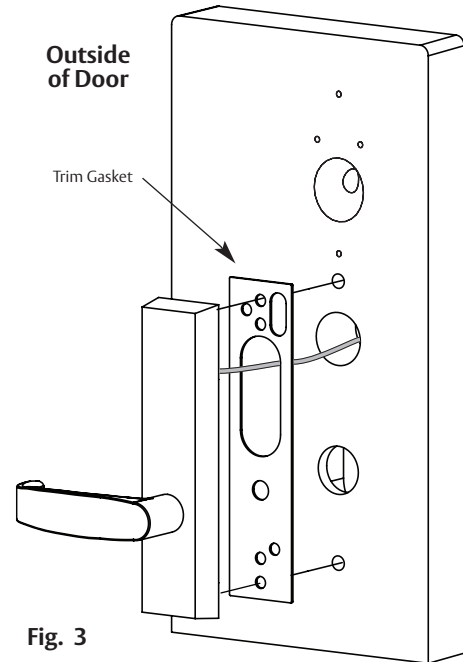

Fig. 3

4 Mounting Chassis

1. Position chassis carefully; avoid pinching wire harness.
2. Trim spindle will engage the lower hub of chassis.
3. Cylinder tailpiece should engage upper hub of the chassis.
4. Through bolt chassis to trim with (2) 1/4 -20 x 2-3/8" flat head machine screws.
5. Using (4) #10 wood screws or #10-24 machine screws fasten chassis to door.

Feed wires up through the routed channel as shown (Fig.).
Note: Keep wires in routed channel.
DO NOT pinch.

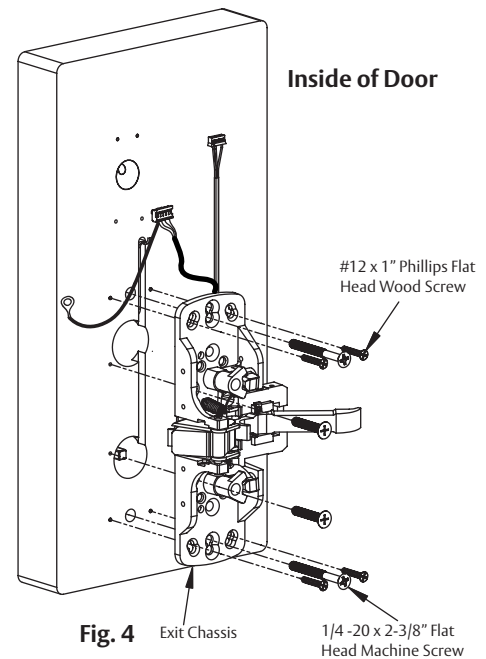

Fig. 4

5 Cylinder Installation (if required)

1. Position cylinder in trim control.
2. For non-Sargent cylinder ONLY: Secure cylinder with cylinder backplate using (2) #12-24 x 1-7/8" screws.

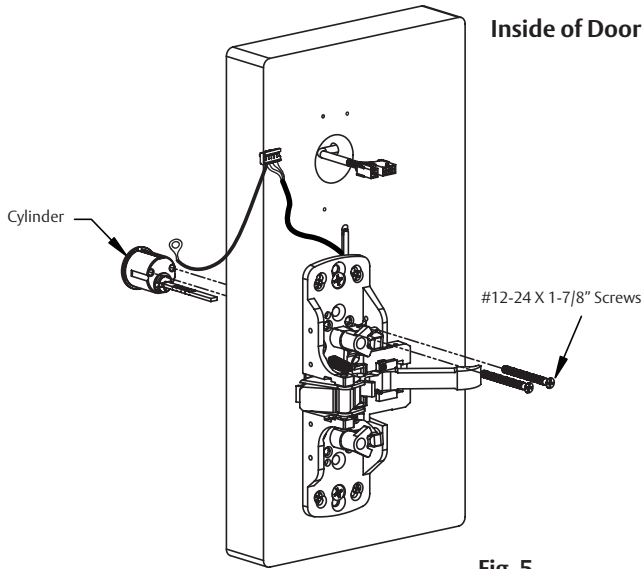

Fig. 5B

Fig. 5

6 Install Reader Backplate and (Optional*) Fire Shield

1. For fire-rated doors only, install reader backplate and fire shield to door using two (2) #8-18 x 5/8" Phillips flat head self-drilling screws (Fig. 6).
2. For exterior doors, install reader backplate using two (2) #8-18 x 5/8" Phillips flat head self-drilling screws (Fig. 6A).
3. *For non-fire rated interior doors, no fire shield is required; simply install backplate using two (2) #8-18 x 5/8" Phillips flat head self-drilling screws.

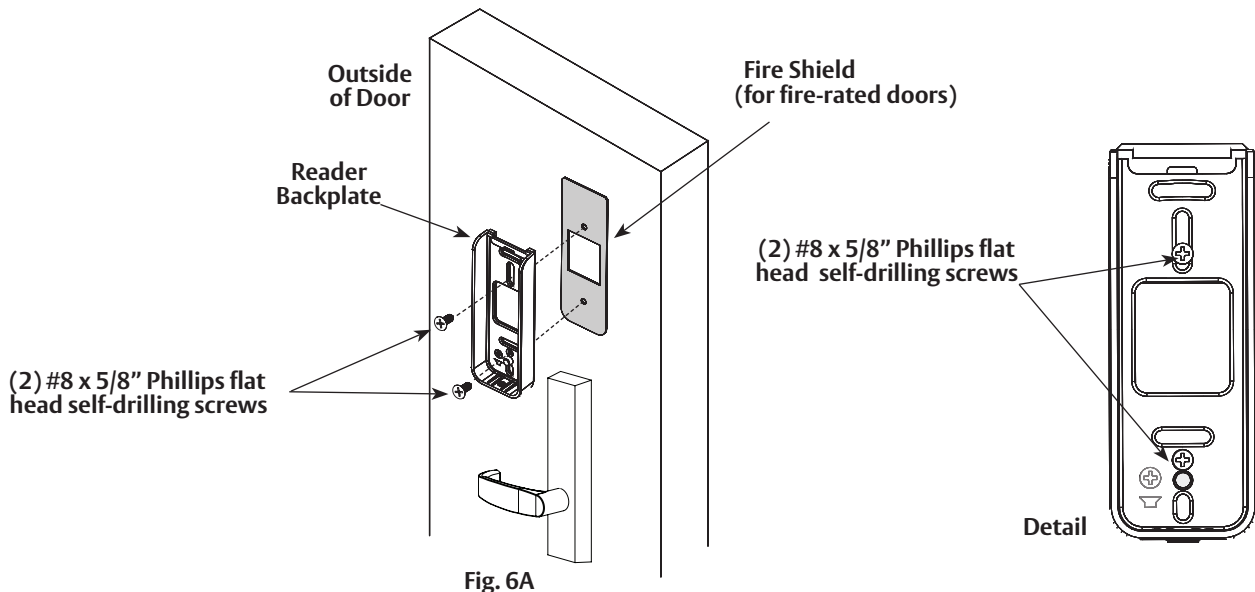

Fig. 6A

7 Installation of SN200/210 Reader



Observe precautions for handling electrostatic sensitive devices.

1. Feed reader harness through door (Fig. 7A).
2. Hook the top of the reader on the top of the mounting plate (Fig. 7B).
3. Align the bottom of the reader with the bottom of the mounting plate.
4. Secure the reader to the mounting plate using the supplied 6-32 x 3/8" T10 security machine screw (Fig. 7C).

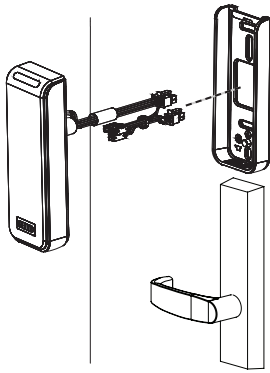

Fig. 7A

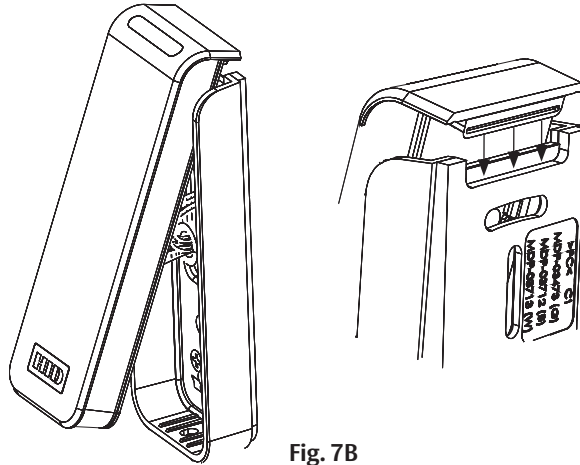
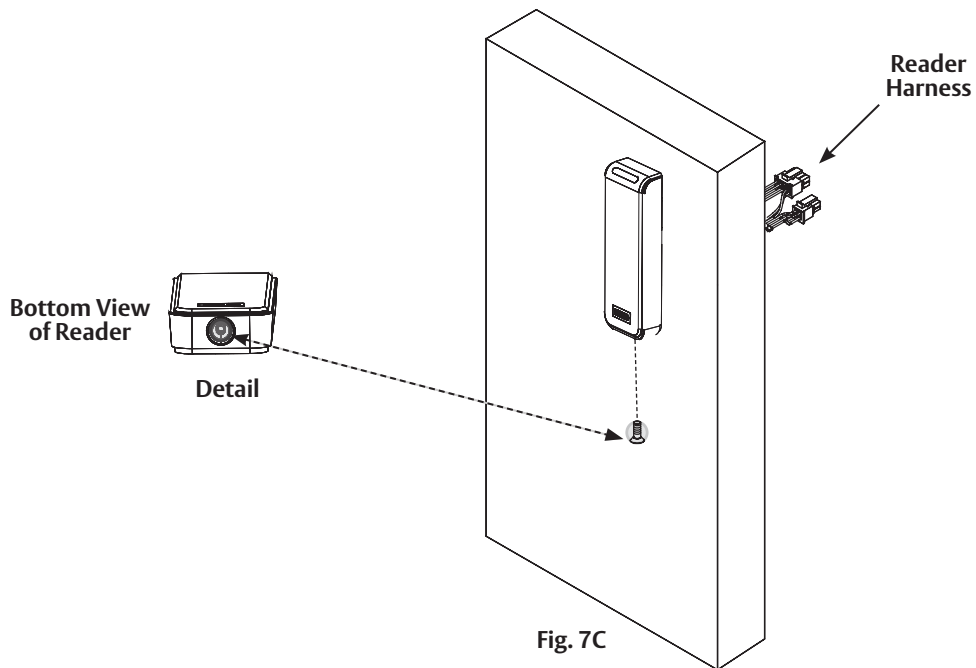
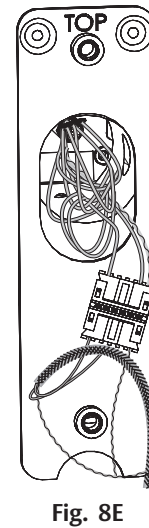
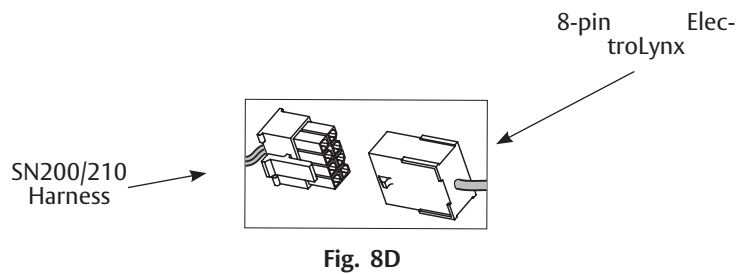
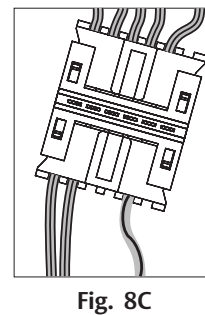
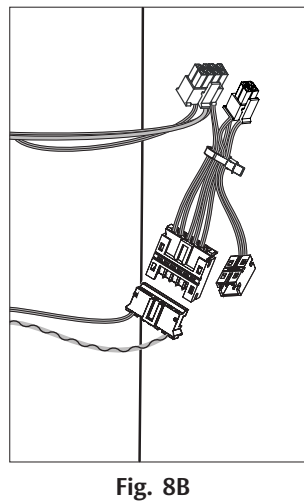
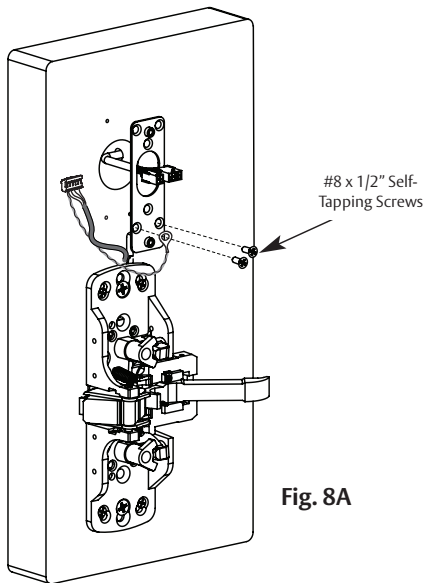

Fig. 7B



8 Inside Mounting Plate and Wire Connections

1. Attach the mounting plate using two (2) #8 x 1/2" lower screws (Fig. 8A). Feed bottom left screw through green/yellow ground wire ring terminal. Install screw. Ensure that green/yellow wire points toward top of door in order to avoid interference with escutcheon. Connect 6-pin connector from lock body to 6-pin connector on reader harness (Fig. 8B, C).
2. Connect ElectroLynx 8-pin connector from the door harness to (black) 8-pin connector of the SN200/210 harness (Fig. 8D).



NOTE: Neatly fold excess wires into remaining space to prevent pinching wires when mounting inside escutcheon (Fig. 8E).

9 Fire Plate Installation (Optional)

1. Fasten plate with two #8 x 1 1/4" Phillips pan head self-drilling screws.
Note: For non-fire rated doors, omit fire plate.

Attach the green/yellow wire ring terminal using (1) #8 1 1/4" Phillips pan head self-drilling screw to the lower left mounting plate screw.

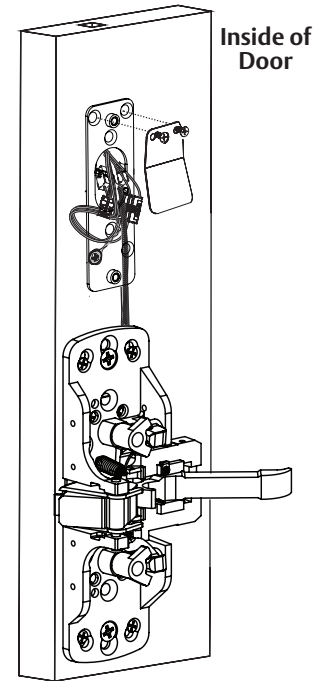

Fig. 9

10 Installation of Rail Assembly

1. Retrieve Request To Exit (REX) harness from end of rail. Harness has limited travel and can be damaged.
2. Attach harness to female connector on chassis.
3. Install rail and screws per exit device instructions.

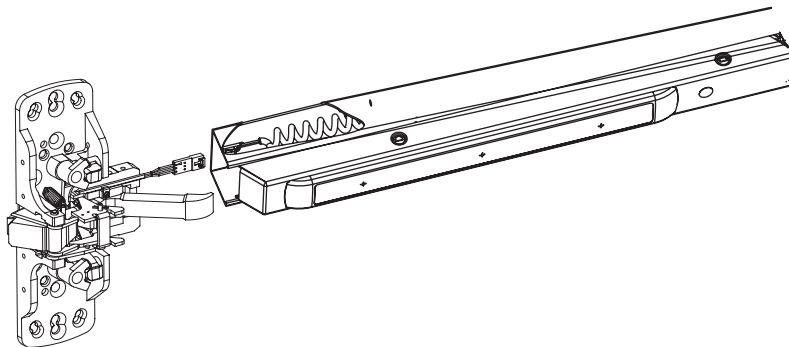
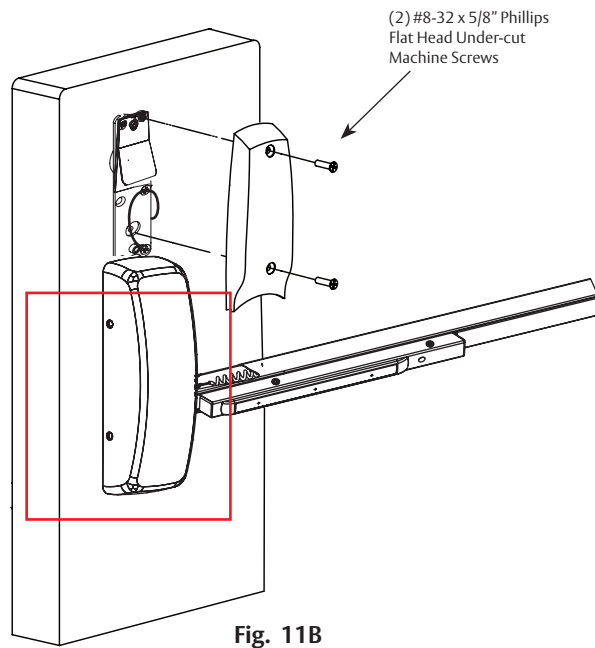
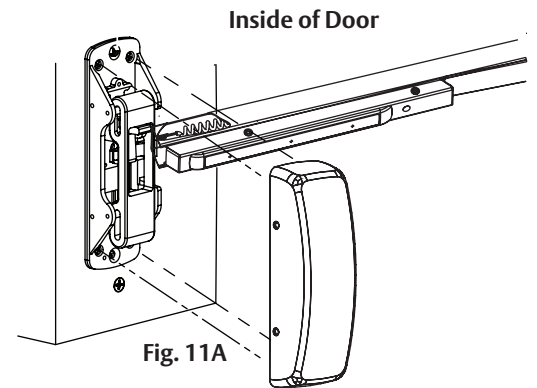

Fig. 10

11 Inside Escutcheon and Lever

1. Secure chassis cover to chassis using (4) #8-32 x 5/16 oval head machine screws (Fig. 11A).
2. Carefully and neatly fold lock body wires into themselves.
3. Position inside escutcheon against left side of mounting plate in order to ensure wires are not pinched. Adjust wires as necessary to ensure they are clear of rear escutcheon. Position inside escutcheon against door (Fig. 11B).

Note: Be sure to cover but not pinch wires when mounting escutcheon.



>>If you are installing 56- ELR Exit Device <<
 Continue to Section 10 Exit Device Controller Configuration Check

8

Installation Instructions SN200/210 (PE)8900 Mortise Exit Device

Parts Breakdown

Left Hand Reverse Door Shown

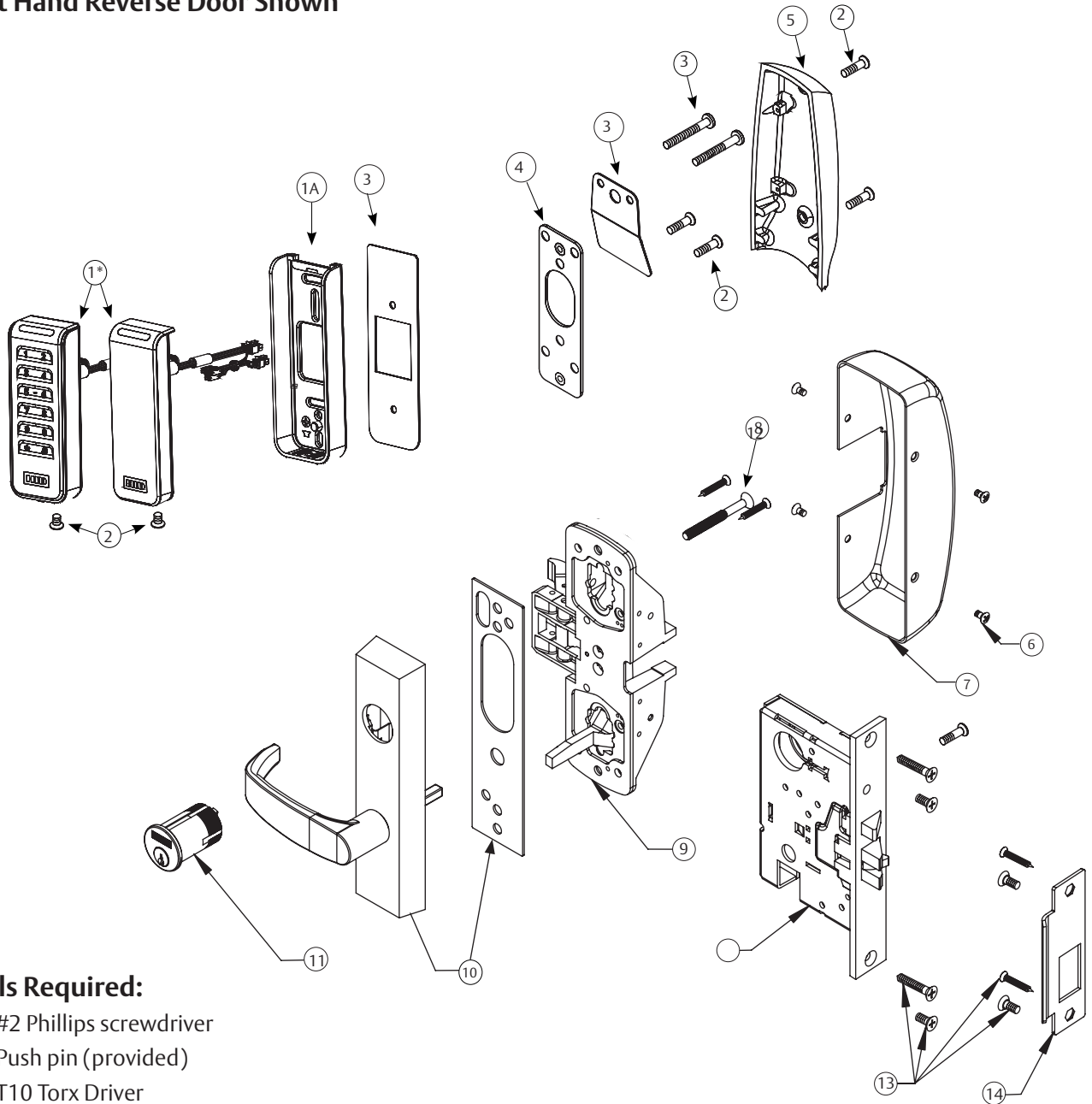

Tools Required:

- #2 Phillips screwdriver
- Push pin (provided)
- T10 Torx Driver
- 3/32" drill bit
- 3/4" drill bit
- 5/16" drill bit
- 3/8" drill bit
- 7/16" drill bit
- 1" bore
- 2-1/8" bore

Copyright © 2020-2023 Sargent Manufacturing Company, an ASSA ABLOY Group company. All rights reserved. Reproductions in whole or in part without express written permission of Sargent Manufacturing Company is prohibited.

01/31/23

Parts Breakdown (PE)8900 (Continued)

ITEM	Description	Req.
1	SN200 Reader & Harness Assembly	1
1A	Signo Reader Back Plate	1
2	Screw Pack	1
3	SN200/210 Standard Fire Kit	1
4	Inside Mounting Plate	1
5	Inside Escutcheon	1
6	Screw Pack (Rail and Chassis Cover)	1
7	Chassis Cover	1
8	Screw Pack (Chassis)	1
9	(PE)8900 Chassis Assembly LHRB	1
	(PE)8900 Chassis Assembly RHRB	1
10	Trim (Trim with gasket shown)	1
11	Reference SN200/210 Catalog for Available Cylinders	1
12	(PE)8900 Lock Body Assembly LHRB	1
	(PE)8900 Lock Body Assembly RHRB	
13	Screw Pack (Mortise Lock)	1
14	Strike Pack (Specify Bevel and Lip Length)	1
15	Door Position Switch (not shown)	1

Copyright © 2020-2023 Sargent Manufacturing Company, an ASSA ABLOY Group company. All rights reserved. Reproductions in whole or in part without express written permission of Sargent Manufacturing Company is prohibited.

01/31/23

8 Installation Instructions (PE)8900 Mortise Exit (Continued)

1 Door Preparation

A. Verify Hand and Bevel of Door

- Check hand of door. Exit Device may be handed.
- Door should be fitted and hung.
- Verify box label for size of exit device, function and hand.

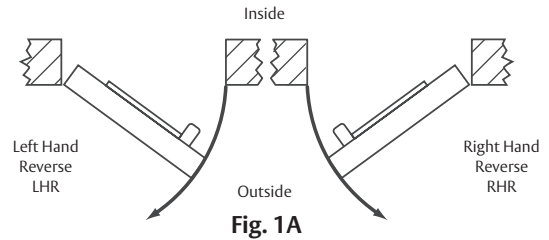

B. Door Preparation

Prepare door according to appropriate template. If necessary, refer to website: www.intelligentopenings.com

- Prior to installation, make sure all holes are free of burrs, debris, and sharp edges.
- If doors are not properly reinforced per ANSI 115.2, commercially available reinforcements should be installed.
- Templates:
 - Field Template (ships with product): **A8128** or **MEFT11** (for PE Series) and **A8129** or **MEFT12** (for PE Series)
 - Door Manufacturer's Template): **4708** or **MEDT57** (for PE Series)

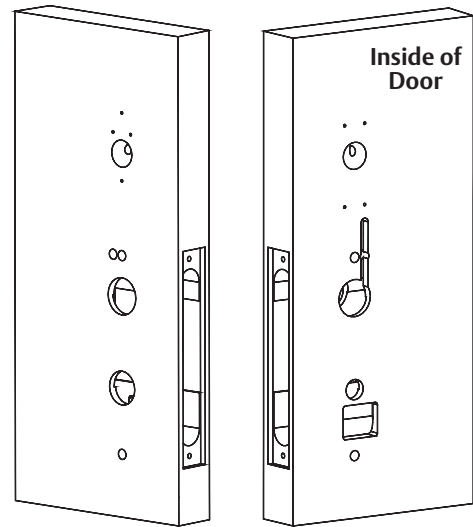

Fig. 1B

2 Concealed Door Position Switch (3287) Instructions

Use SARGENT 3287 Concealed Door Position Switch with this SN200/210 product.

1. Install the 3287 Concealed Door Position Switch described in SARGENT document A7448.
2. Wire the 3287 Concealed Door Position Switch to the EAC door position Input.
3. Connect the common wire of the switch to the common input terminal of the EAC; and the normally open wire of the switch to the normally open input terminal of the EAC.

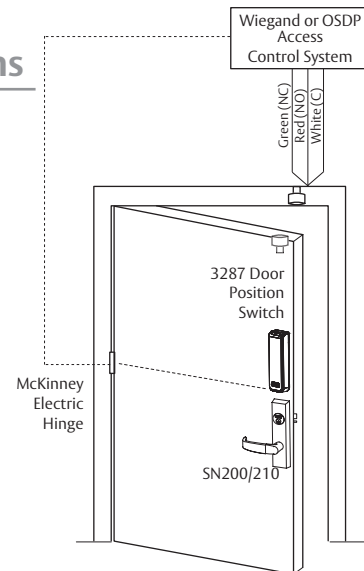

Fig. 2

3 Mortise Lock and Outside Exit Trim Installation

1. Slide mortise lock into pocket and securely fasten with (2) flat head screws (Fig. 3A).
2. For exterior applications, use trim gasket to seal between trim escutcheon and outside door surface (Fig. 3B Detail). NOTE: For 56- ELR install, skip Step 3.
3. For wood doors: Route trim wire harness connector through the cylinder hole, up and through the wire run channel to the controller cutout.

For metal doors: Route trim wire harness through the cylinder hole out the controller cutout.

4. Place trim control on door with spindle engaging the mortise lock.

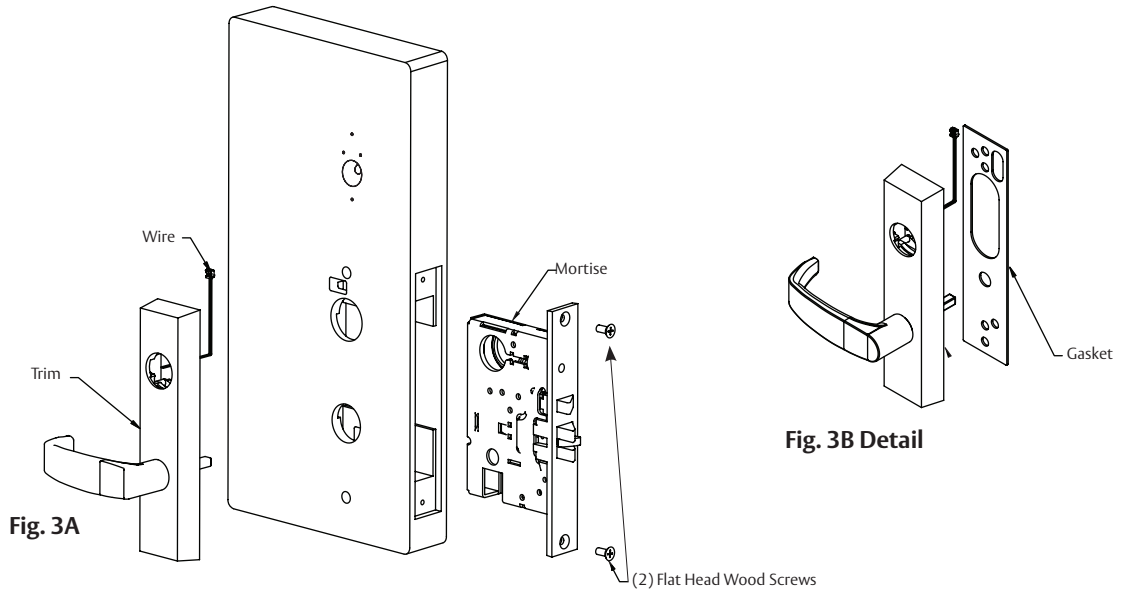

4 Cylinder Installation

For devices without cylinders, skip this section.

1. Back cylinder set screw out slightly (Fig. 4A).
2. Insert cylinder through trim control and thread into mortise lock until cylinder is flush with trim.
Keyway must be vertical and SARGENT Position Sargent Logo at top of cylinder (Fig. 4B).
3. Tighten cylinder set screw.

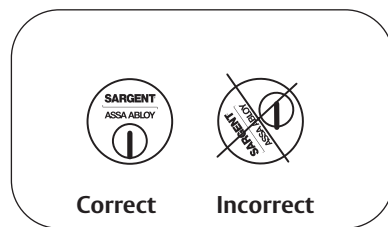

Fig. 4B

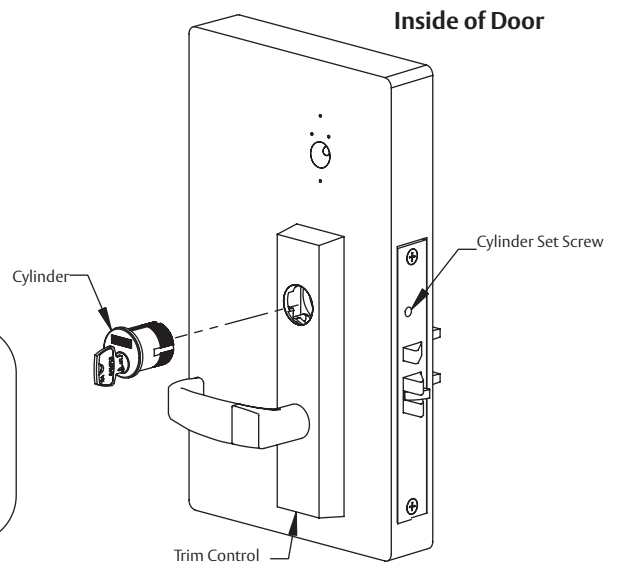
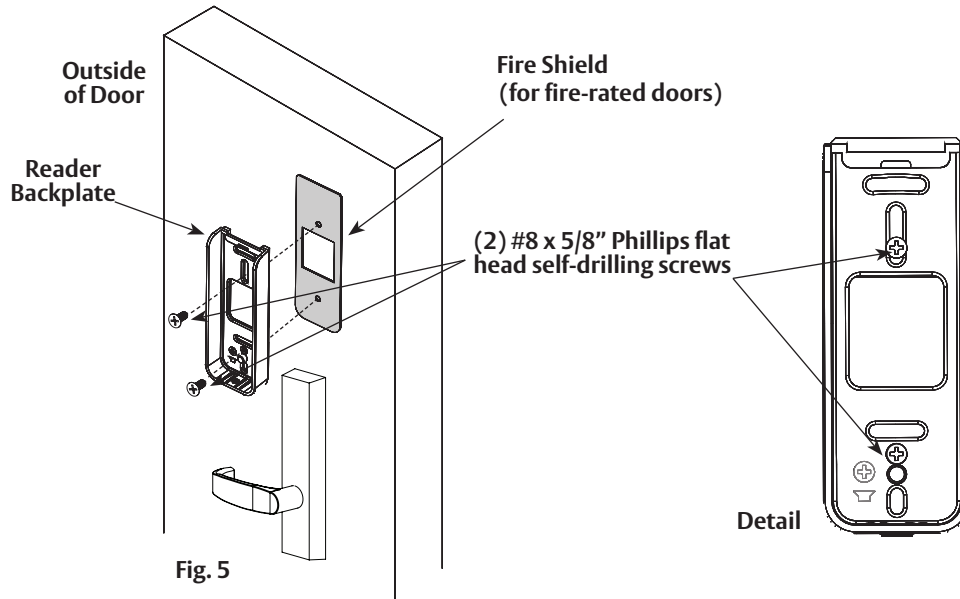

Fig. 4A

Experience a safer
and more open world

5 Install Reader Backplate and (Optional*) Fire Shield

1. For fire-rated doors only, install reader backplate and fire shield to door using two (2) #8-18 x 5/8" Phillips flat head self-drilling screws (Fig. 5).
2. For exterior doors, install reader backplate using two (2) #8-18 x 5/8" Phillips flat head self-drilling screws (Fig. 5).
3. *For non-fire rated interior doors, no fire shield is required; simply install backplate using two (2) #8-18 x 5/8" Phillips flat head self-drilling screws.



6 Installation of SN200/210 Reader



Observe precautions for handling electrostatic sensitive devices.

1. Feed reader harness through door (Fig. 6A).
2. Hook the top of the reader on the top of the mounting plate (Fig. 6B).
3. Align the bottom of the reader with the bottom of the mounting plate.
4. Secure the reader to the mounting plate using the supplied 6-32 x 3/8" T10 security Torx machine screw (Fig. 6C).

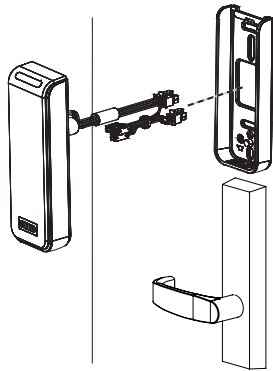

Fig. 6A

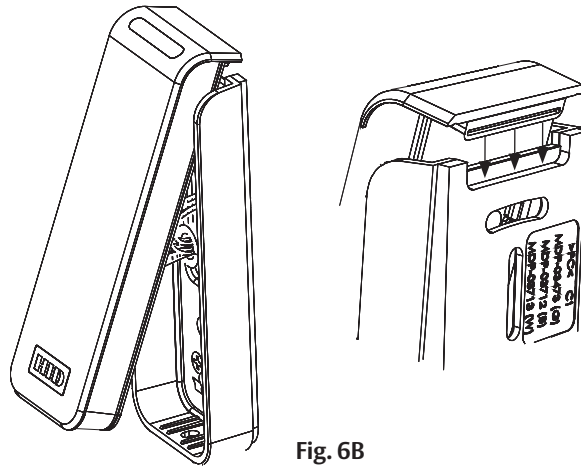

Fig. 6B

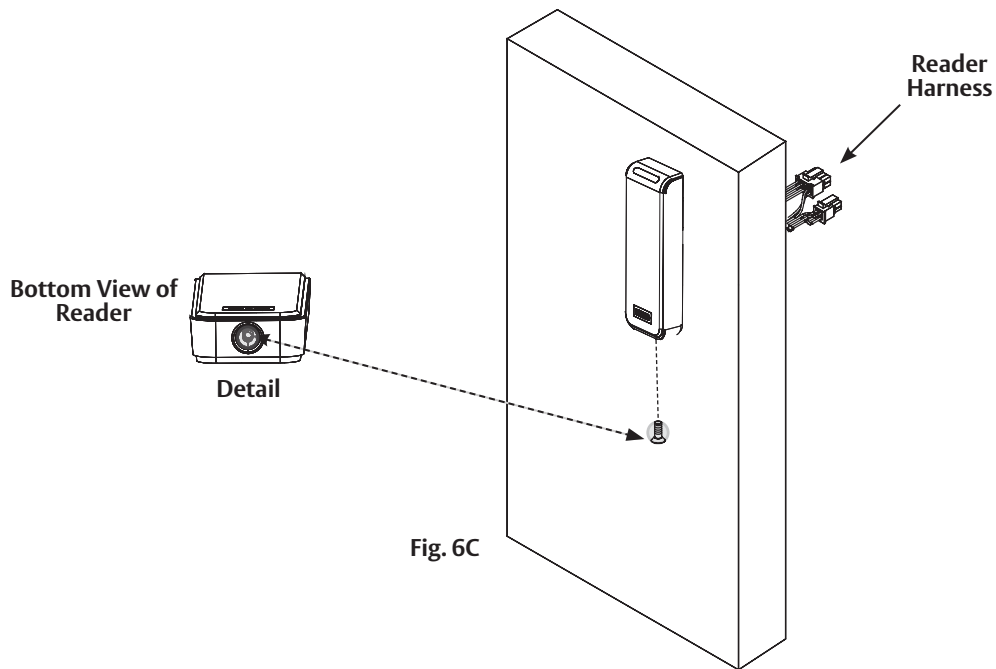
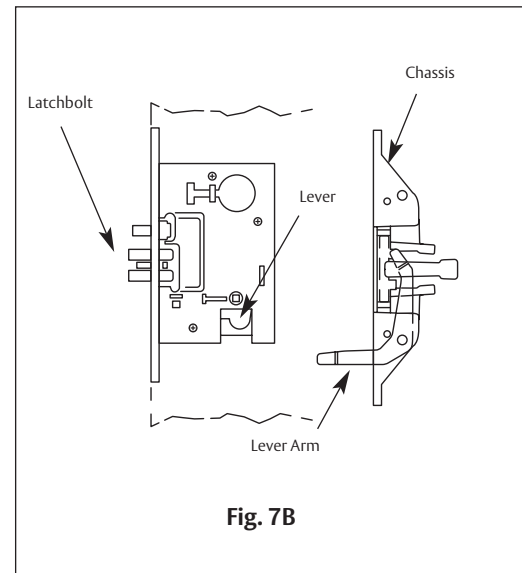
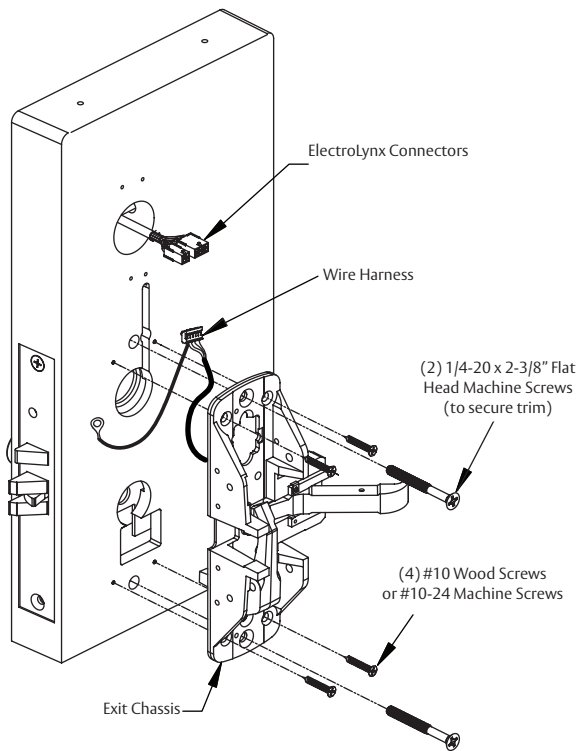

Fig. 6C

7 Chassis to Door Installation

1. Route wire harness along track cutout for wood doors and access hole for metal doors (Fig. 7A).
2. Position chassis on door so that lever arm is under rear section of mortise lock lever.
Next (while holding down the chassis lift arm), lift up until latch bolt is completely retracted.
With chassis in this position, mark location of chassis mounting holes (Fig. 7B).
Drill holes for screws.
3. Mount chassis on door. Do not pinch harness wires.
4. Fasten exit chassis to door using (4) #10 wood screws or #10-24 x 3/4" machine screws.
5. Using (2) 1/4-20 x 2-3/8" flat head screws, attach trim to chassis.



8 Inside Mounting Plate and Wire Connections

NOTE: Feed door harness through the corresponding hole on the mounting plate.

1. Attach the mounting plate using two (2) #8 x 1/2" lower screws (Fig. 6). Feed bottom left screw through green/yellow ground wire ring terminal. Install screw. Ensure that green/yellow wire points toward top of door in order to avoid interference with escutcheon.
2. If fire kit is not being used, install (2) #8 x 1/2" in upper mounting plate holes.
3. Connect 6-pin connector from lock body to P3 (6-pin) on reader harness.
4. Carefully tuck ElectroLynx connectors into 1 inch hole in door (Fig. 8B).

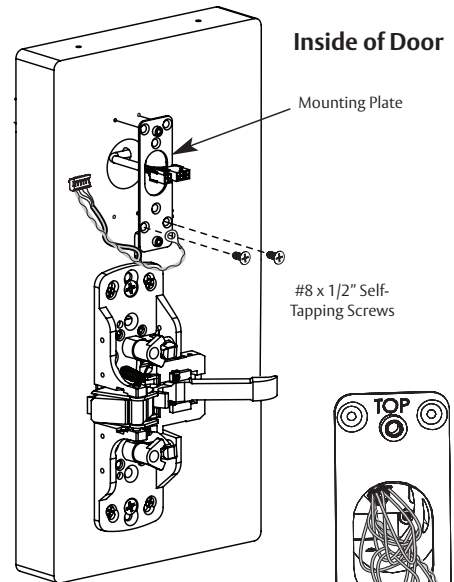

Fig. 8A

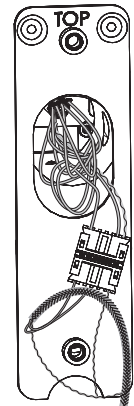

Fig. 8B

9 Fire Plate Installation*

1. Fasten plate with two (2) #8 x 1 1/4" Phillips pan head self-drilling screws.

*Note: For non-fire rated doors, omit fire plate.

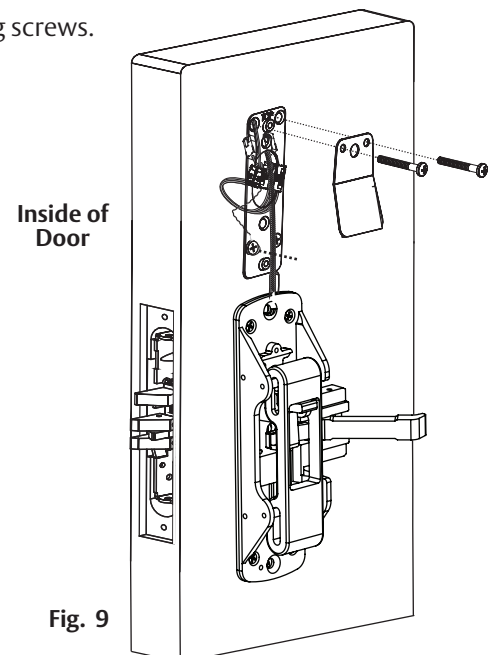

Fig. 9

10 Installation of Rail Assembly

1. Retrieve Request To Exit (REX) harness from end of rail. Harness has limited travel and can be damaged.
2. Attach harness to female connector on chassis.
3. Install rail and screws per exit device instructions.

Note: This view shows rim exit device version

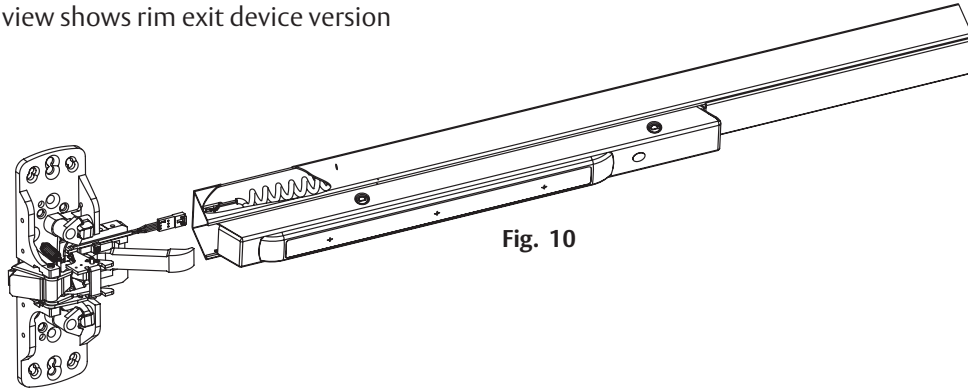

Fig. 10

11 Installation of Inside Escutcheon

1. Secure chassis cover to chassis using (4) #8-32 x 5/16 oval head machine screws (Fig. 11A).
2. Position inside gasket and escutcheon against door. Verify that no wires are pinched.
3. Mount inside escutcheon assembly to plate using (2) #8-32 x 5/8" Phillips flat head undercut machine screws (Fig. 11B).

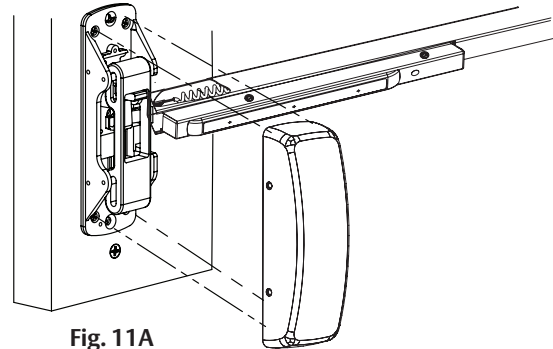

Fig. 11A

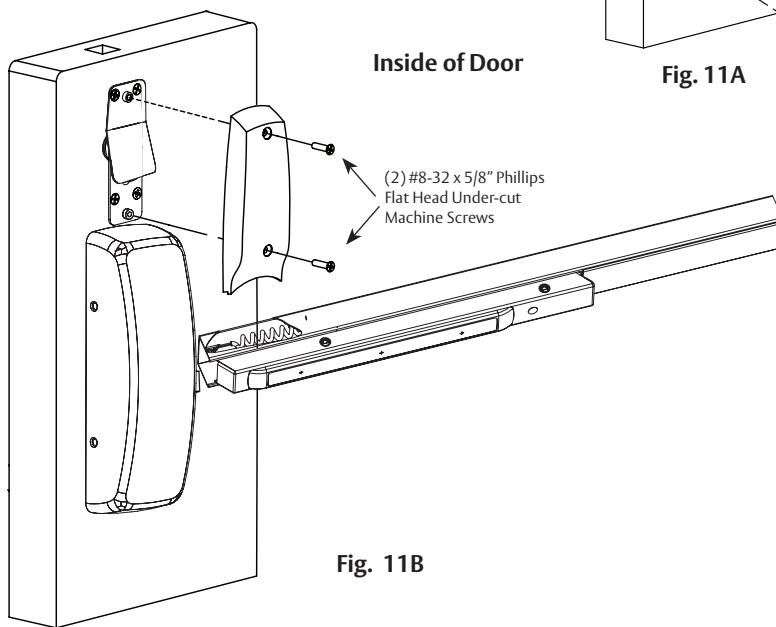

Fig. 11B

**>>If you are installing 56- ELR Exit Device <<
Continue to Section 10 56- ELR Operational Check**

9

56- ELR Exit Device Controller Configuration Check

1. Locate controller at end of rail (Fig. 12A).
2. Ensure 'Power Mode' is set to ON as shown in Detail 12B.

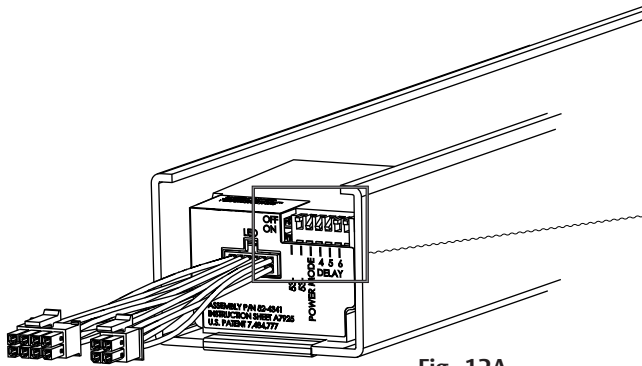

Fig. 12A

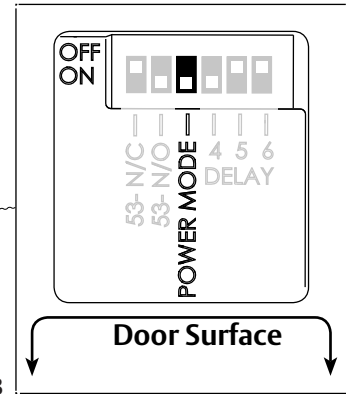

Fig. 12B

NOTE: For more information, refer to 56- Installation Instructions (A7925)

>> Continue to Section 5 for Wiring Diagrams to wire device to EAC panel <<

10 Operational Check

Wiegand Test Unit

The ASSA ABLOY Wiegand Test Unit verifies your installation in the field*. The test unit checks for:

- proper wiring
- card reader data integrity
- lock functionality including lock/unlock, door position status, and request-to-exit (REX) status

In addition, this tool provides demonstration abilities to highlight the product's features and capabilities**.

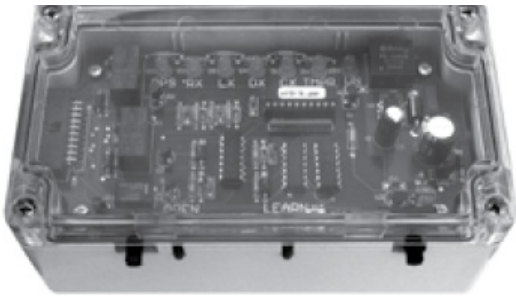

Wiegand Test Unit - WT1



Wiegand Test Unit - WT2

Feature	WT1	WT2
12 or 24VDC solenoid lock voltage adjustable	X	X
Operates as Fail Safe or Fail Secure	X	X
"Learn" mode allows testing of specific cards without programming at panel level	X	X
Card reader data integrity is validated at test unit	X	X
Displays detailed Wiegand data, including hexadecimal string and total bits received		X
Displays measured end-of-line resistor values (if applicable)		X
Displays key-press data from keypad readers†		X

*For directions on use, see operating instructions provided with unit.

**SN200/210 keypad version works only with WT2

† WT2 unit with 1.03 firmware or later is required

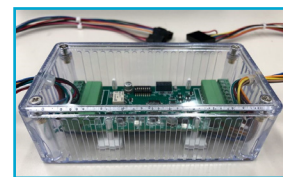

(SNT1) WTU OSDP adapter wiring harness

The SNT1 is an adapter harness assembly that connects and converts OSDP lock signaling to work with a Wiegand Test Unit (WTU).

If using the OSDP adapter, the WT1 will unlock on credential read or any key press, regardless of what credential is learned (OSDP reader only).

When connected to a Wiegand reader or using OSDP adapter: the WT2 will unlock on credential read and display credential value. Credentials can be learned, as usual. Individual key press will be displayed for any key press, but they cannot be learned.

10 Operational Check (Continued)

NOTE: Ensure LED operates as configured:

- LED remains green when panel asserts GREEN_LED signal or issues OSDP command

For devices without cylinders, go to step 3.

1. For devices with cylinders, insert key into cylinder and rotate.
2. The key will retract the latch and rods, the key should rotate freely.
3. Depress inside rail to retract latch and rods.

Note: Once electrical wiring has been successfully completed according to proper application, perform the following:

1. Ensure lock is interfaced with Wiegand Test Unit to verify installation & wiring up to the point of hinge (frame side).
2. Turn power ON.
3. Wait for LED to turn RED and then present a compatible credential and verify LED and sounder activity.
4. Verify valid card read on Wiegand Test Unit or at the EAC panel.
5. Verify system operation functions; i.e., when a valid credential is presented to reader, the door should unlock (or 56- will retract).

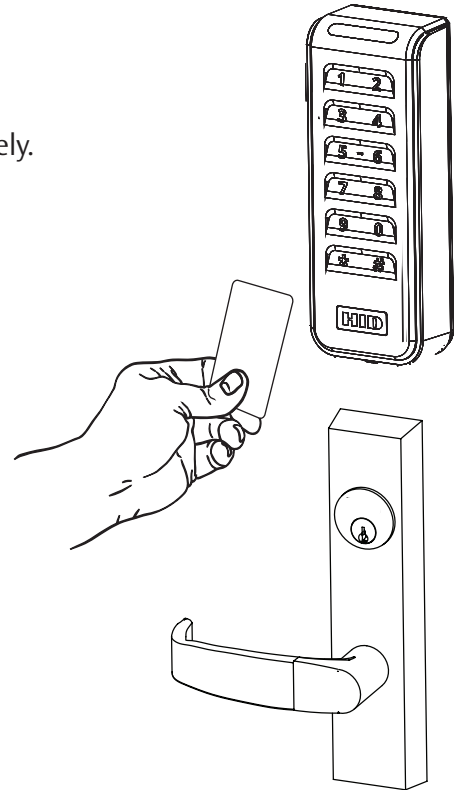

If the lock fails to operate when DC voltage is applied:

1. Remove power.
2. Confirm the polarity of the supply (i.e., '+' is positive).

If the lock is functioning opposite to the desired fail-safe or fail-secure operation:

1. Remove power and check the "Fail" condition by attempting to rotate the outside lever (e.g. if fail-secure, the outside lever should be rigid with power removed).

SARGENT®

ASSA ABLOY

SN200/210 Exit Device

Copyright © 2020-2023 Sargent Manufacturing Company, an ASSA ABLOY Group company. All rights reserved.
Reproductions in whole or in part without express written permission of Sargent Manufacturing Company is prohibited.

01/31/23

Experience a safer
and more open world

The ASSA ABLOY Group is the global leader in access solutions. Every day, we help billions of people experience a more open world.

ASSA ABLOY Opening Solutions leads the development within door openings and products for access solutions in homes, businesses and institutions. Our offering includes doors, frames, door and window hardware, mechanical and smart locks, access control and service.

SARGENT[®]
ASSA ABLOY

SARGENT Manufacturing
100 Sargent Drive
New Haven, CT 06511 USA
800-727-5477 • www.sargentlock.com

Copyright © 2020-23 Sargent Manufacturing Company, an ASSA ABLOY Group company. All rights reserved.
Reproduction in whole or in part without the express written permission of Sargent Manufacturing Company is prohibited.
Patent pending and/or patent - www.assaabloydss.com/patents.
HID, iCLASS, and Edge are trademarks or registered trademarks of HID Global Corporation.

A8284B-01/23