

Installation Instructions

SARGENT
ASSA ABLOY

Dummy Rail

PE8893 & PE8895 Exit Devices

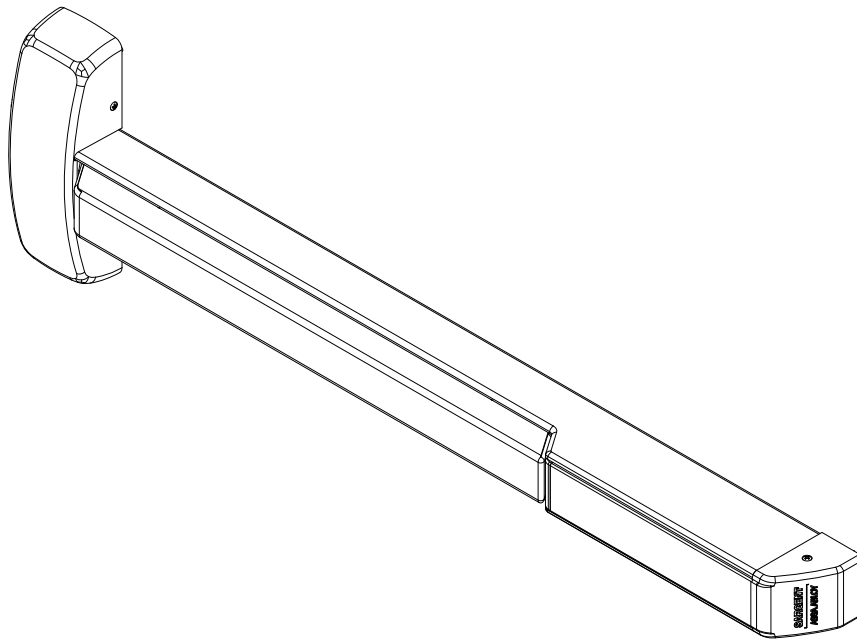

WARNING

This product can expose you to lead which is known to the state of California to cause cancer and birth defects or other reproductive harm. For more information go to www.P65warnings.ca.gov.

WARNING

Attention Installer: Improper installation may result in damage to the product and void the factory warranty.

1-800-727-5477 • www.sargentlock.com

Copyright © 2023, SARGENT Manufacturing Company. All rights reserved. Reproduction in whole or in part without the express written permission of SARGENT Manufacturing Company is prohibited. Patent pending and/or patent www.assaabloyds.com/patents.

A8320-1 5/23

Experience a safer
and more open world

Dummy Rail







PE8893 Exit Device

Installation Instructions

SARGENT

ASSA ABLOY

Screw Chart

DESCRIPTION	TOTAL QTY SUPPLIED	WHERE USED
 <p>#10-24 X 3/4" FLAT HEAD MACHINE SCREW</p>	4	(4) CHASSIS CORNER MOUNTING HOLES (METAL DOOR)
 <p>#10 X 1-1/4" FLAT HEAD WOOD SCREW</p>	4	(4) CHASSIS CORNER MOUNTING HOLES (WOOD DOOR)
 <p>#10-24 X 3/4" ROUND HEAD MACHINE SCREW</p>	2	(2) REAR MOUNTING PLATE (METAL DOOR)
 <p>#10 X 1-1/4" ROUND HEAD WOOD SCREW</p>	2	(2) REAR MOUNTING PLATE (WOOD DOOR)
 <p>#8-32 X 5/16" W/ #6 OVAL HEAD MACHINE SCREW</p>	6	(4) CHASSIS COVER (2) END CAP
 <p>1/4"-20 X 2-3/8" KNURLED FLAT HEAD MACHINE SCREW</p>	2	(2) EXIT TRIM (IF USED)

Dummy Rail

PE8893 Exit Device

Installation Instructions

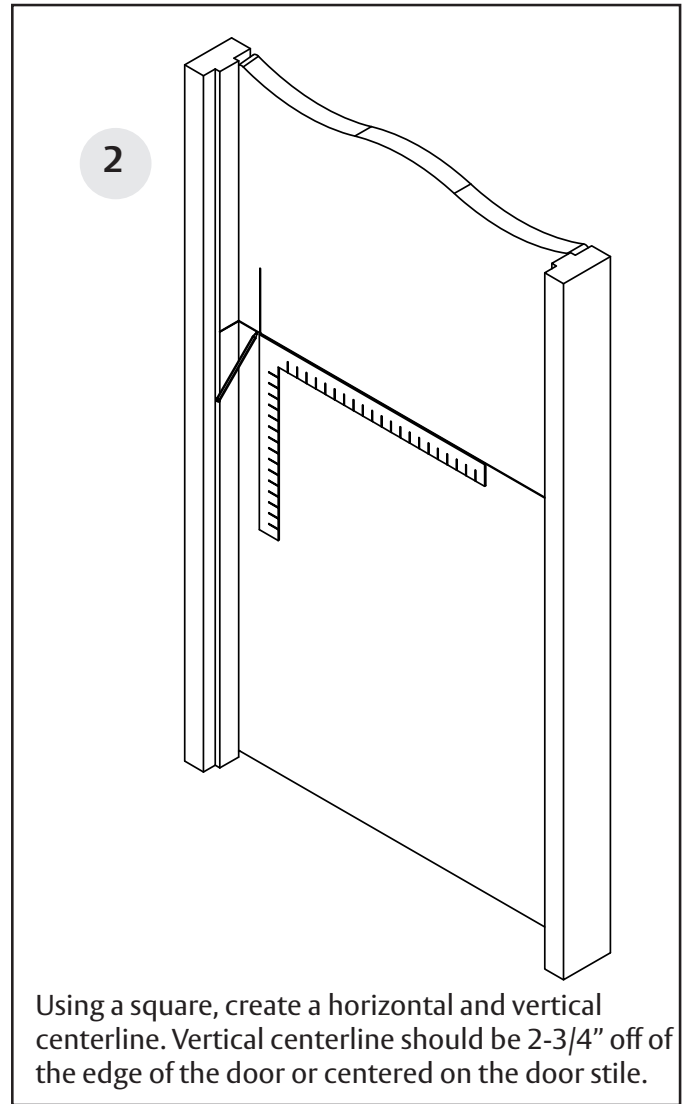
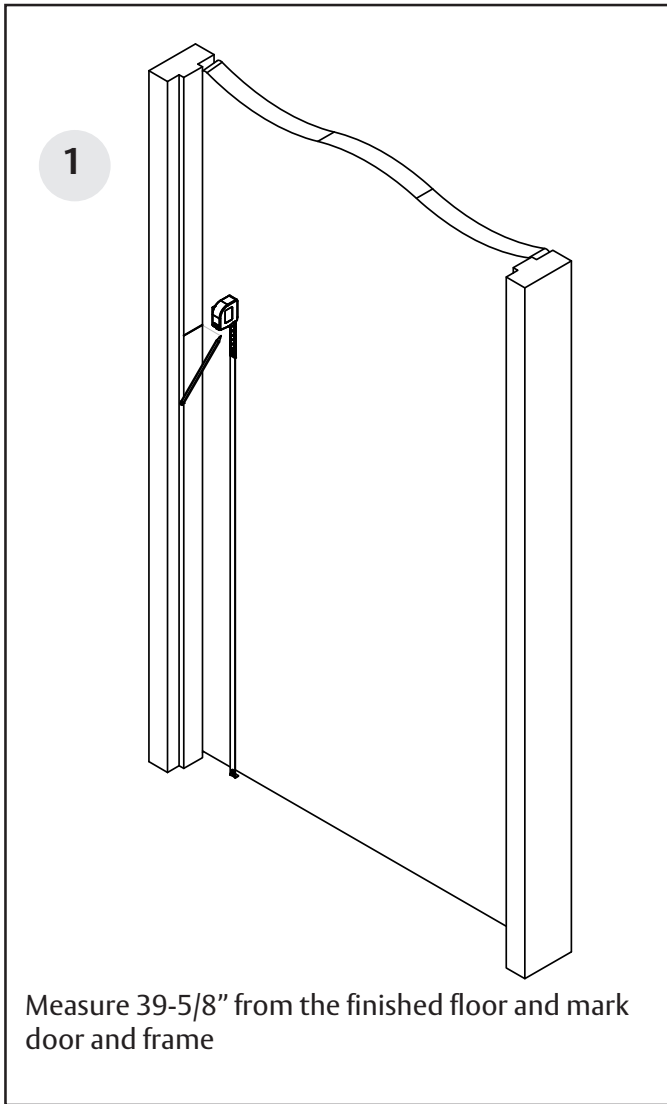

Dummy Rail

PE8893 Exit Device

Installation Instructions

SARGENT

ASSA ABLOY

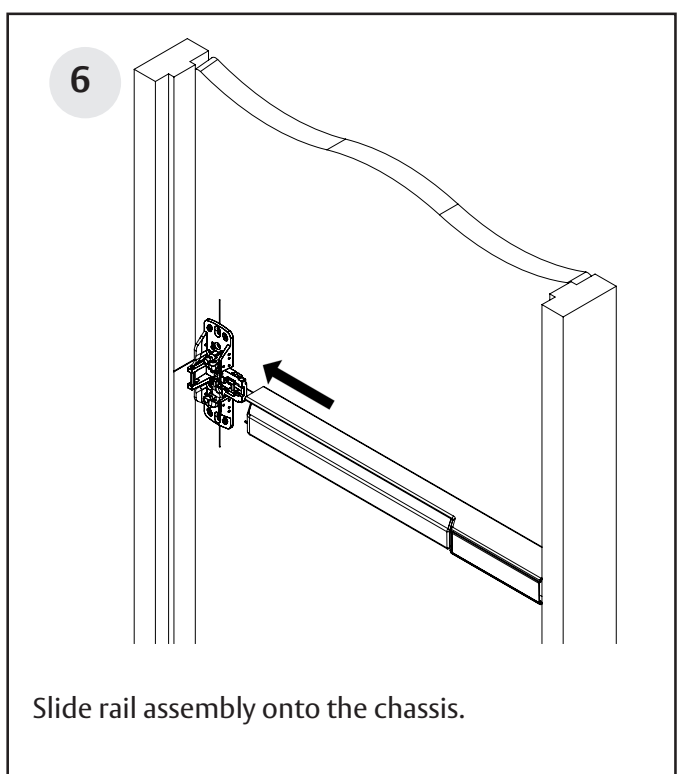
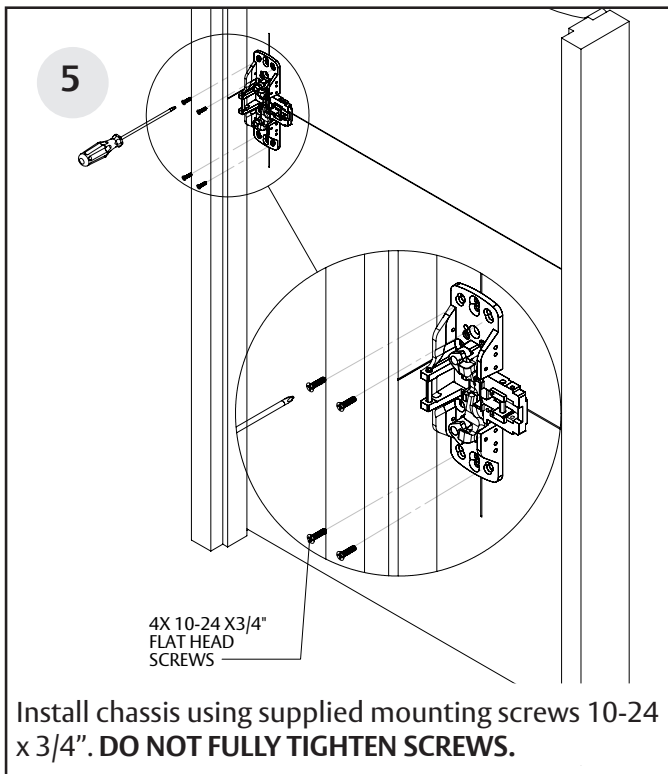
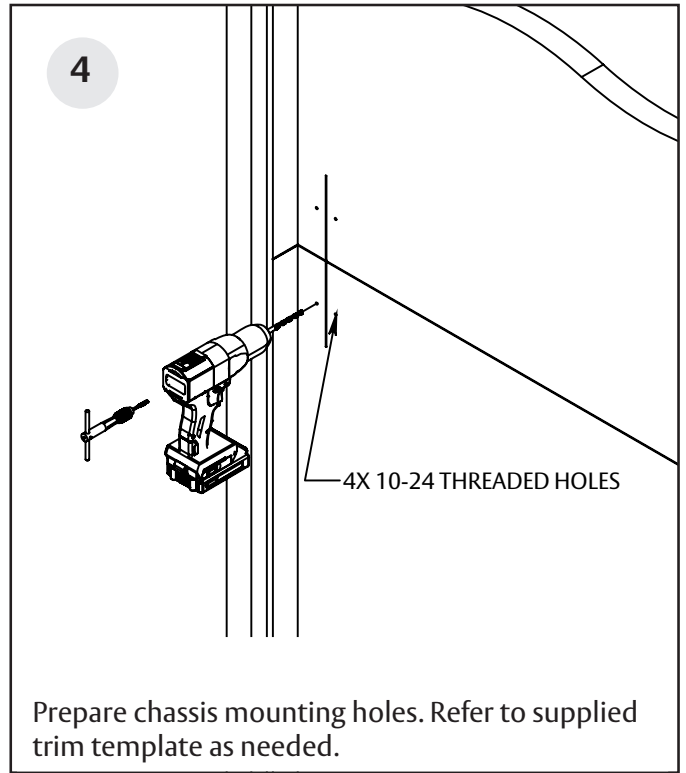
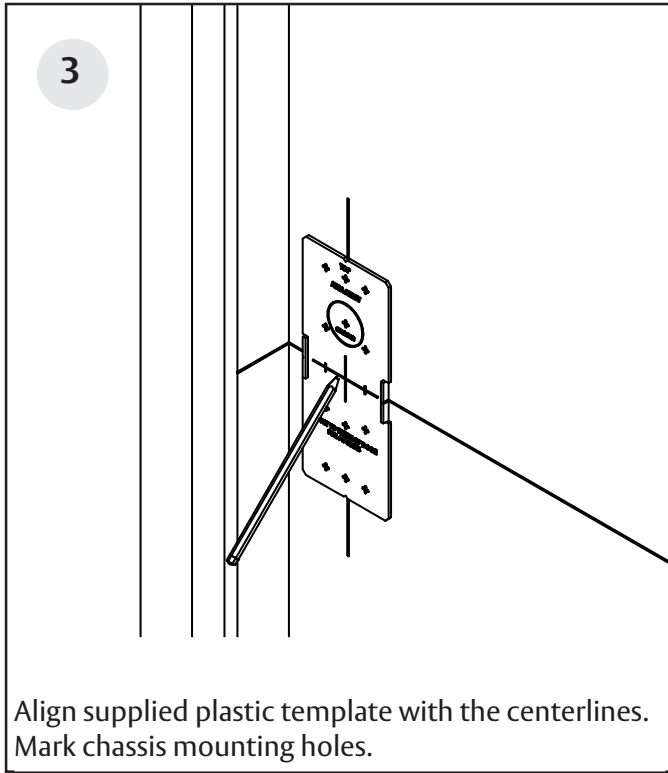

Dummy Rail

PE8893 Exit Device

Installation Instructions

SARGENT

ASSA ABLOY

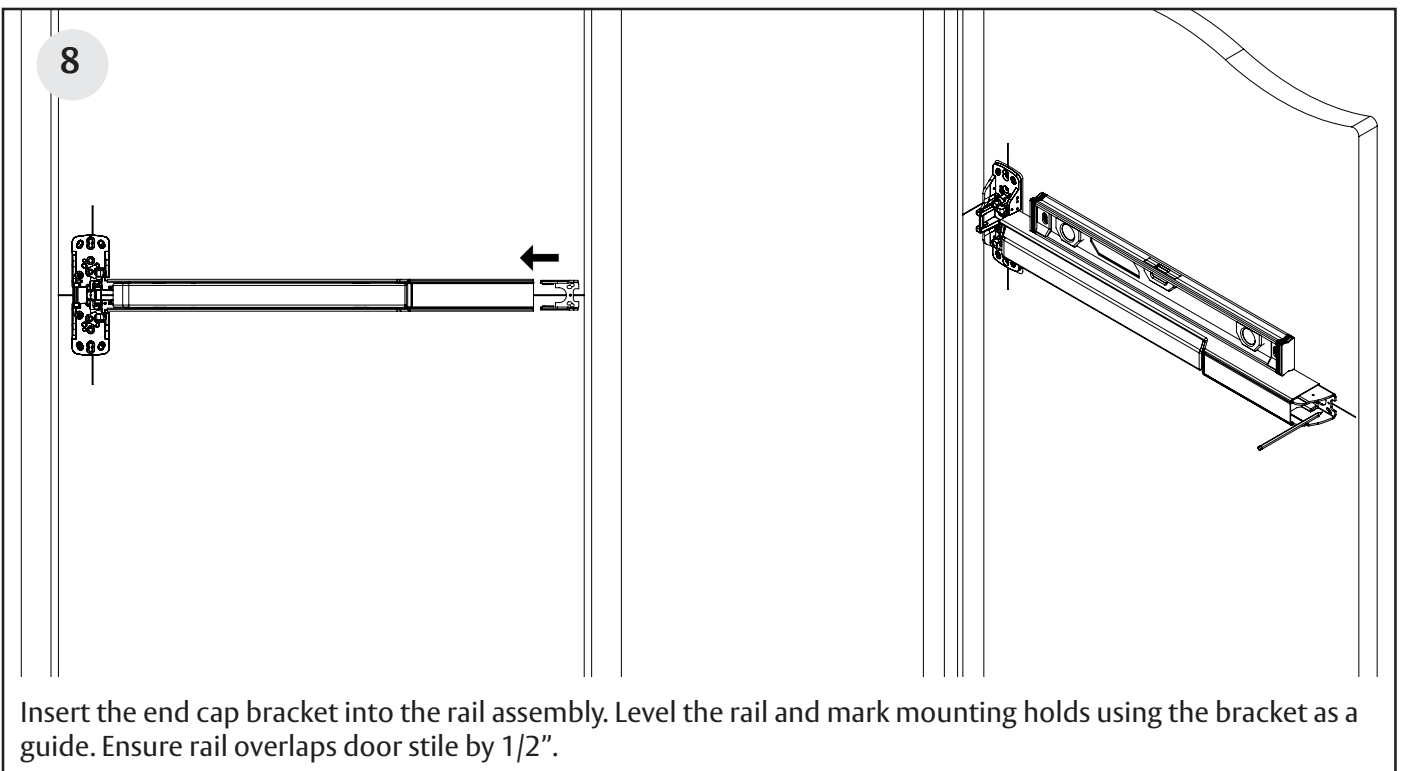
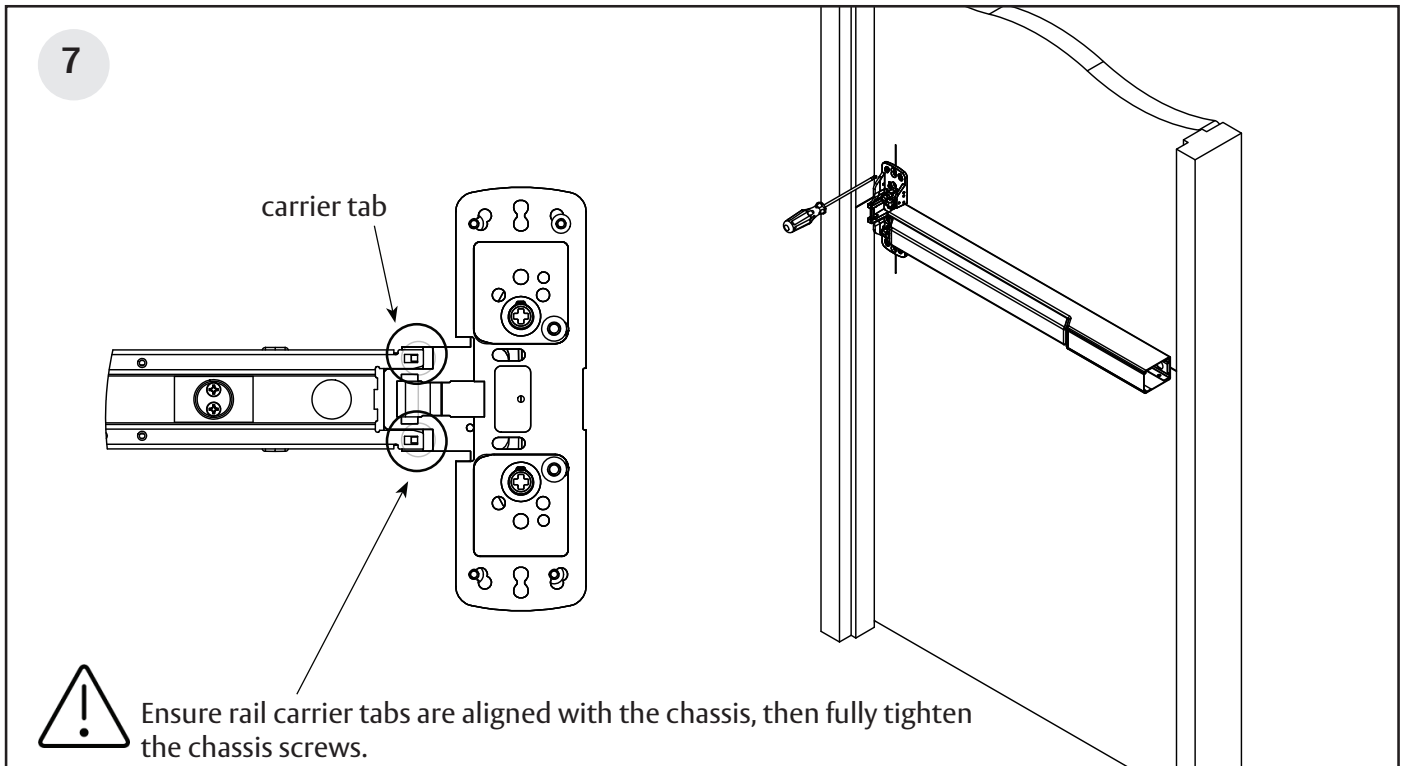

Dummy Rail

PE8893 Exit Device

Installation Instructions

SARGENT

ASSA ABLOY

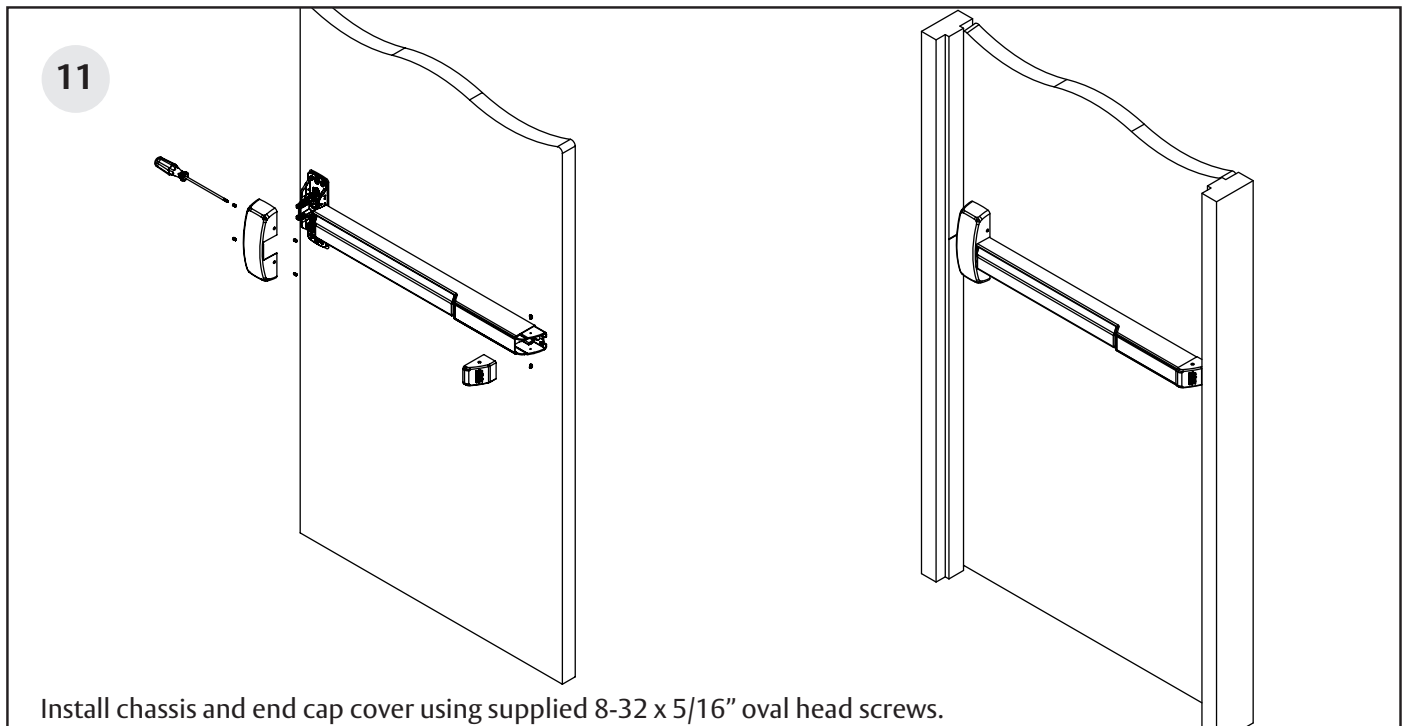
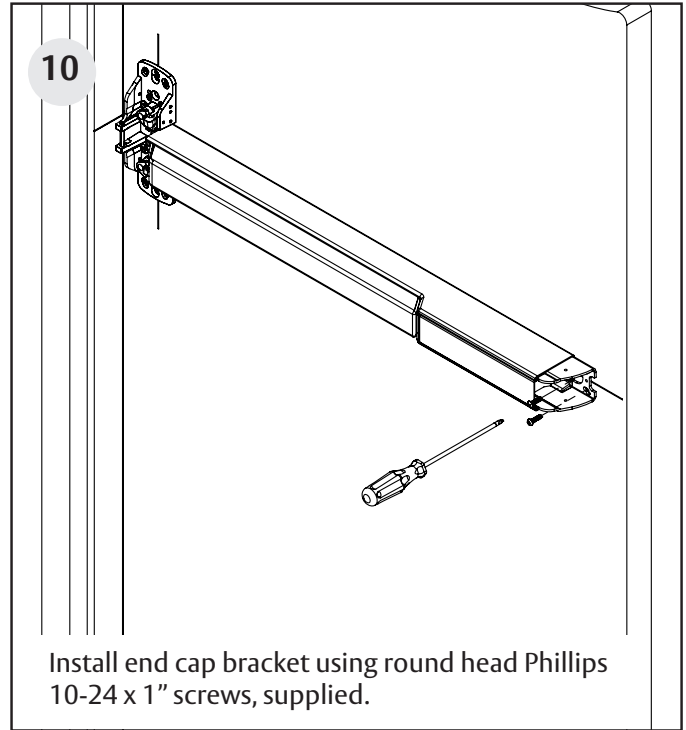
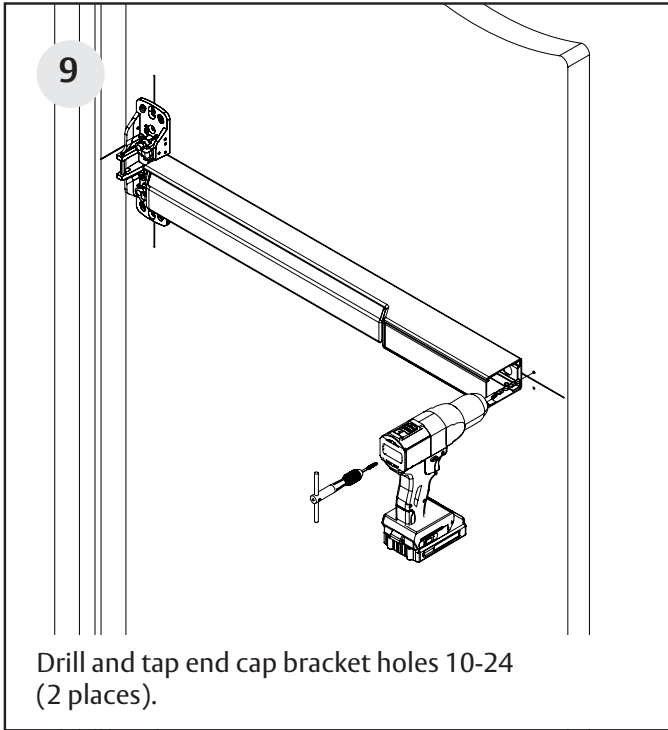

Dummy Rail

PE8893 Exit Device

Installation Instructions



