

# Installation Instructions

**SARGENT**  
**ASSA ABLOY**

## PE8600 Series (12-WD, WD, NB-12-WD, & NB-WD)

### Concealed Vertical Rod Exit Devices

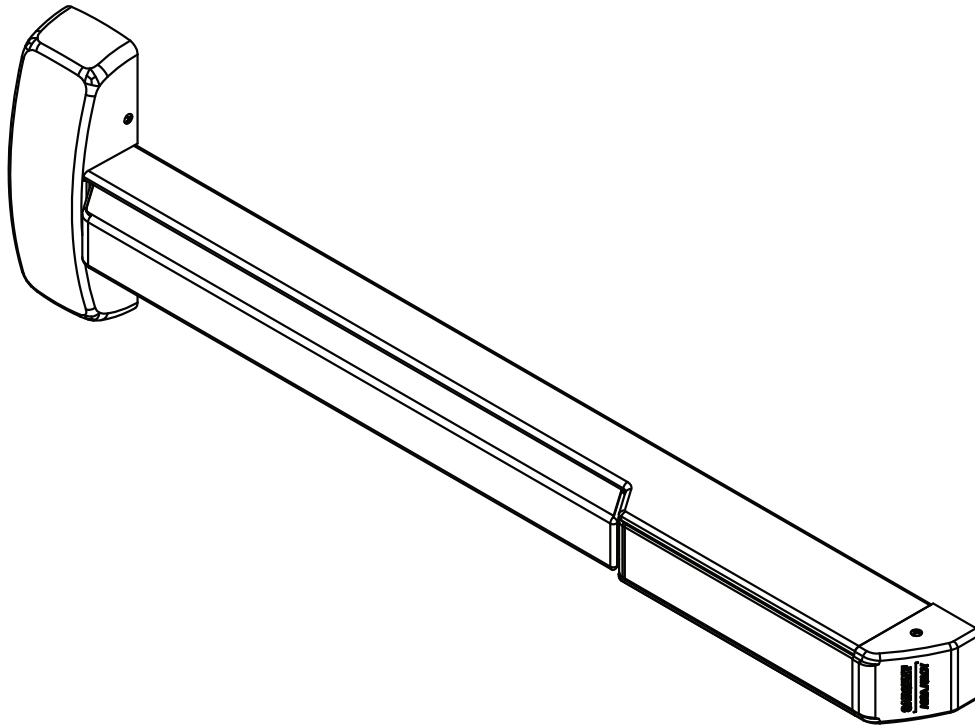

#### **WARNING**

This product can expose you to lead which is known to the state of California to cause cancer and birth defects or other reproductive harm. For more information go to [www.P65warnings.ca.gov](http://www.P65warnings.ca.gov).

#### **WARNING**

Attention Installer: Improper installation may result in damage to the product and void the factory warranty.

1-800-727-5477 • [www.sargentlock.com](http://www.sargentlock.com)

Copyright © 2023, SARGENT Manufacturing Company. All rights reserved. Reproduction in whole or in part without the express written permission of SARGENT Manufacturing Company is prohibited. Patent pending and/or patent [www.assaabloyds.com/patents](http://www.assaabloyds.com/patents).

A8315-1 5/23

Experience a safer  
and more open world

# PE8600 Series (12-WD, WD, NB-12-WD & NB-WD)









**SARGENT**

**ASSA ABLOY**

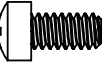
## Concealed Vertical Rod Exit Devices

### Installation Instructions

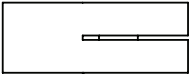
#### Screw Chart

DESCRIPTION	TOTAL QTY SUPPLIED	WHERE USED
 <p style="text-align: center;">(CC)</p> <p style="text-align: center;">#10 X 1-1/4" FLAT HEAD WOOD SCREW</p>	10	(4) CHASSIS CORNER MOUNTING HOLES (2) INNER CHASSIS PLATE (2) 650 STRIKE, TOP (WOOD FRAME) (2) 650 STRIKE, BOTTOM (WOOD FRAME)
 <p style="text-align: center;">(BB)</p> <p style="text-align: center;">#10 X 1-1/4" ROUND HEAD WOOD SCREW</p>	2	(2) REAR MOUNTING PLATE (WOOD DOOR)
 <p style="text-align: center;">(HH)</p> <p style="text-align: center;">#10-24 X 3/8" FILLISTER HEAD MACHINE SCREW</p>	1	(1) INNER CHASSIS
 <p style="text-align: center;">(AA)</p> <p style="text-align: center;">#12 X 2" FLAT HEAD WOOD SCREW</p>	4	(4) TOP CASE BRACKET
 <p style="text-align: center;">(DD)</p> <p style="text-align: center;">1/4" X 1/2" FLAT HEAD WOOD SCREW</p>	2	(2) BOTTOM BRACKET
 <p style="text-align: center;">#10-24 X 1/2" U'CUT FLAT HEAD MACHINE SCREW</p>	4	(2) 650 STRIKE, TOP (METAL FRAME) (2) 650 STRIKE, BOTTOM (METAL FRAME)
  <p style="text-align: center;">1/4"-20 X 2" FLAT HEAD MACHINE SCREW W/ANCHOR</p>	2	(2) 606 BOTTOM STRIKE (FIRE RATED)
 <p style="text-align: center;">(FF)</p> <p style="text-align: center;">#8-32 X 5/16" W/ #6 OVAL HEAD MACHINE SCREW</p>	6	(4) CHASSIS COVER (2) END CAP
 <p style="text-align: center;">(GG)</p> <p style="text-align: center;">1/4"-20 X 2-3/8" KNURLED FLAT HEAD MACHINE SCREW</p>	2	(2) EXIT TRIM (IF USED)

# PE8600 Series (12-WD, WD, NB-12-WD & NB-WD)

# SARGENT

# ASSA ABLOY

## Concealed Vertical Rod Exit Devices

### Installation Instructions

### Equipment Needed

#### Tools

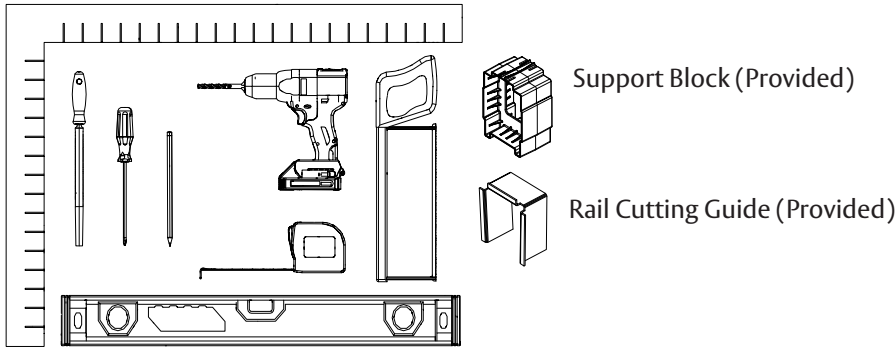

#### Strike Packs

Strike Pack for WD-PE8600

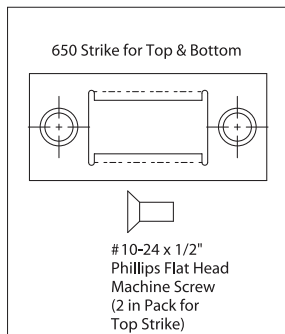

Strike Pack for 12-WD-PE8600

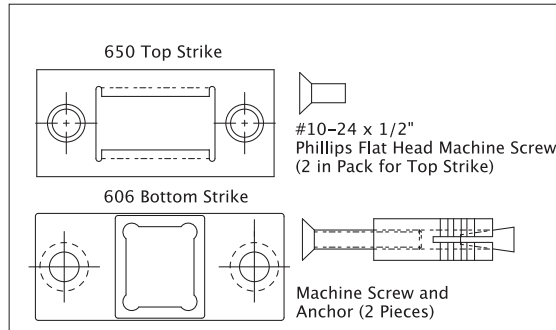

650 Top Strike Pack NB-WD-PE8600 & 12-NB-WD-PE8600

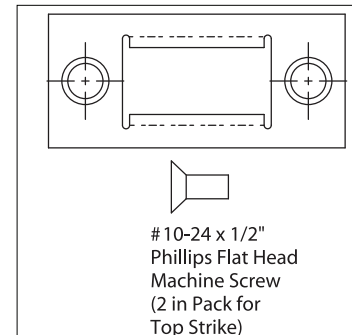

\*Note: The NB-WD-PE8600, 12-NB-WD-PE8600 do not have a bottom strike.



#### Before installation:

1. Fit and hang door.
2. Check the box's label for the size of the exit device.



The surface of the door where the exit device is to be applied must be flush. Clear away any raised projections to allow exit device to rest on the flat surface of the door. If shim kit is required, contact your distributor.

Note: Please refer to trim and other installation instructions provided in the box.

# PE8600 Series (12-WD, WD, NB-12-WD & NB-WD)

**SARGENT**

**ASSA ABLOY**

## Concealed Vertical Rod Exit Devices

### Installation Instructions

### Template for WD-PE8600, 12-WD-PE8600, NB-WD-PE8600 and NB-12-WD-PE8600 with P700 Series Trim

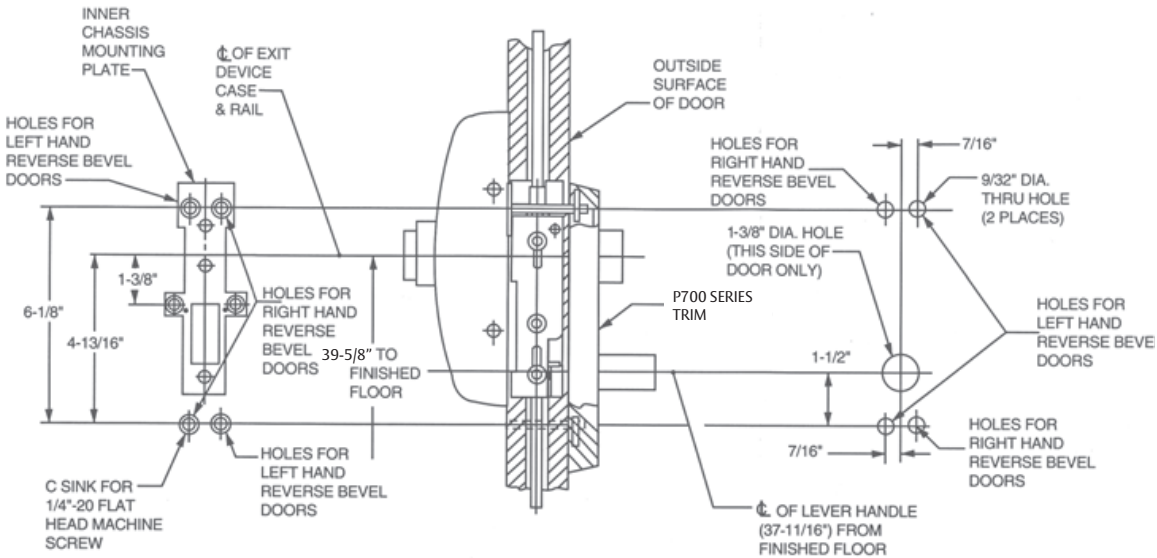

The P700-4 series trim needs to be attached through the door with (2) 1/4-20 x 2-3/8" flat head machine screws (GG).



# PE8600 Series (12-WD, WD, NB-12-WD & NB-WD)

# SARGENT®

# ASSA ABLOY

## Concealed Vertical Rod Exit Devices

### Installation Instructions

#### Exploded View

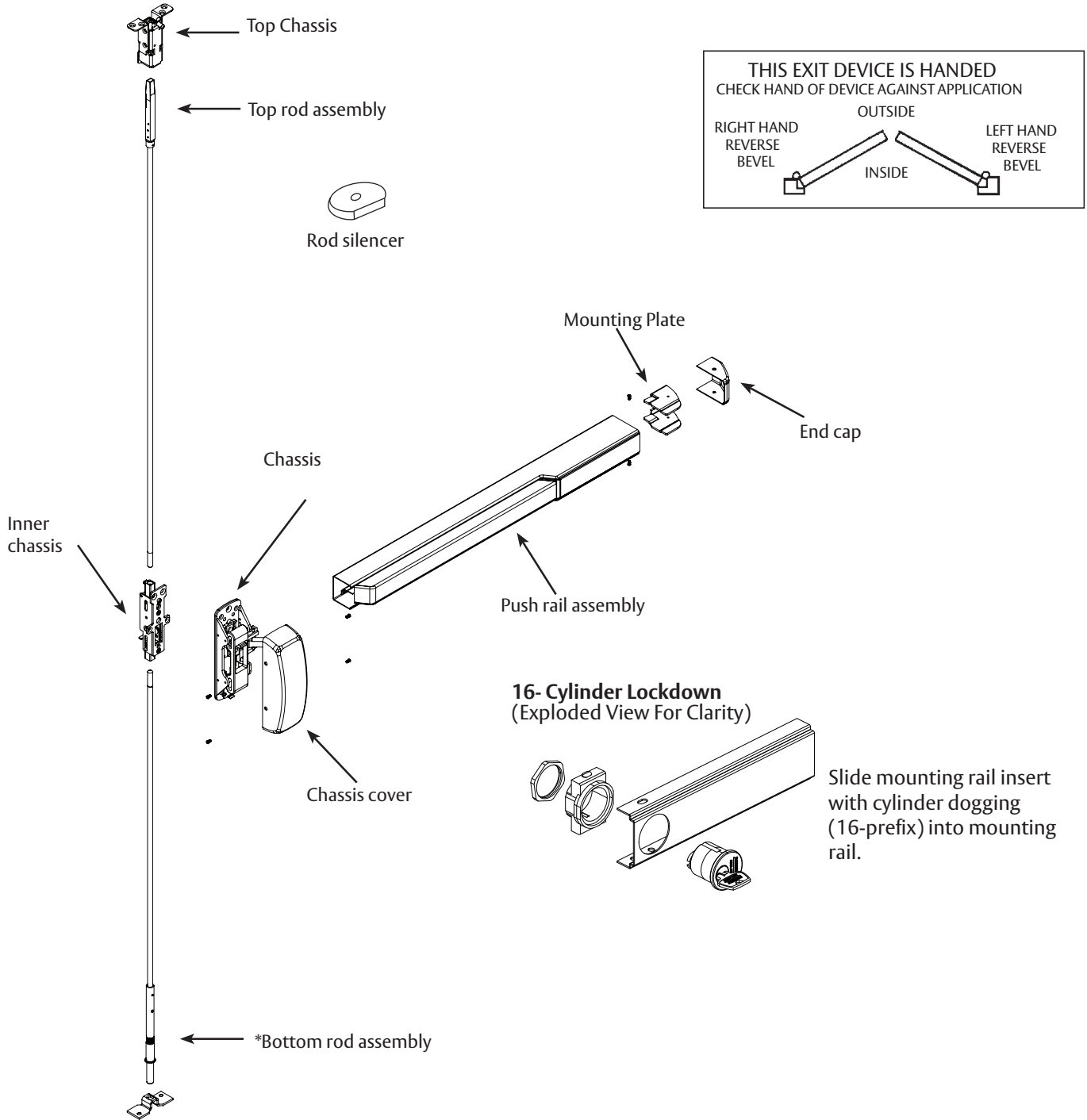

\*Note: The NB-WD-PE8600 and the 12-NB-WD-PE8600 do not have a bottom rod assembly.

1-800-727-5477 • [www.sargentlock.com](http://www.sargentlock.com)

Copyright © 2023, SARGENT Manufacturing Company. All rights reserved. Reproduction in whole or in part without the express written permission of SARGENT Manufacturing Company is prohibited. Patent pending and/or patent [www.assaabloyds.com/patents](http://www.assaabloyds.com/patents).

# PE8600 Series (12-WD, WD, NB-12-WD & NB-WD)

**SARGENT**

**ASSA ABLOY**

## Concealed Vertical Rod Exit Devices

### Installation Instructions

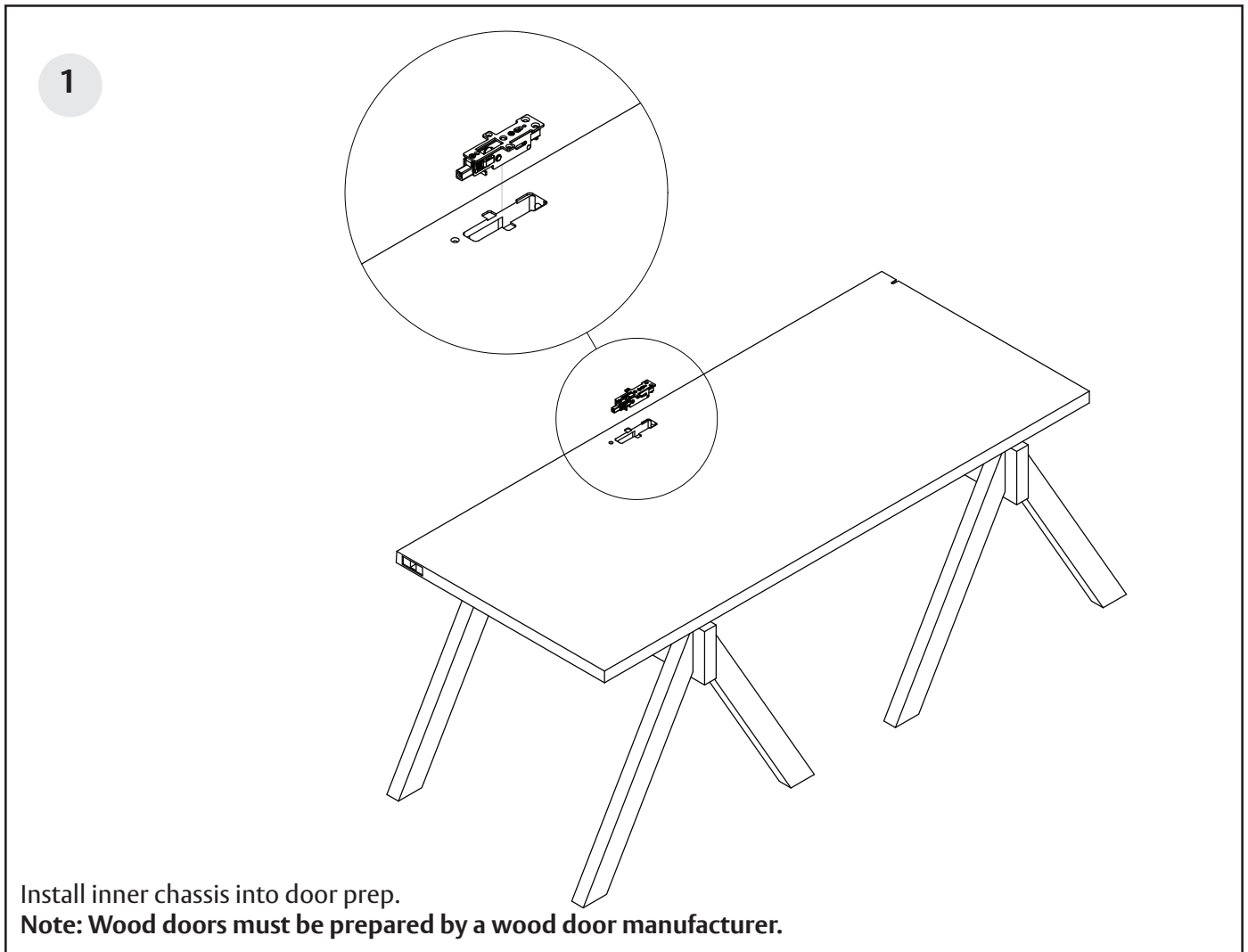

# PE8600 Series (12-WD, WD, NB-12-WD & NB-WD)

**SARGENT**

**ASSA ABLOY**

## Concealed Vertical Rod Exit Devices

### Installation Instructions

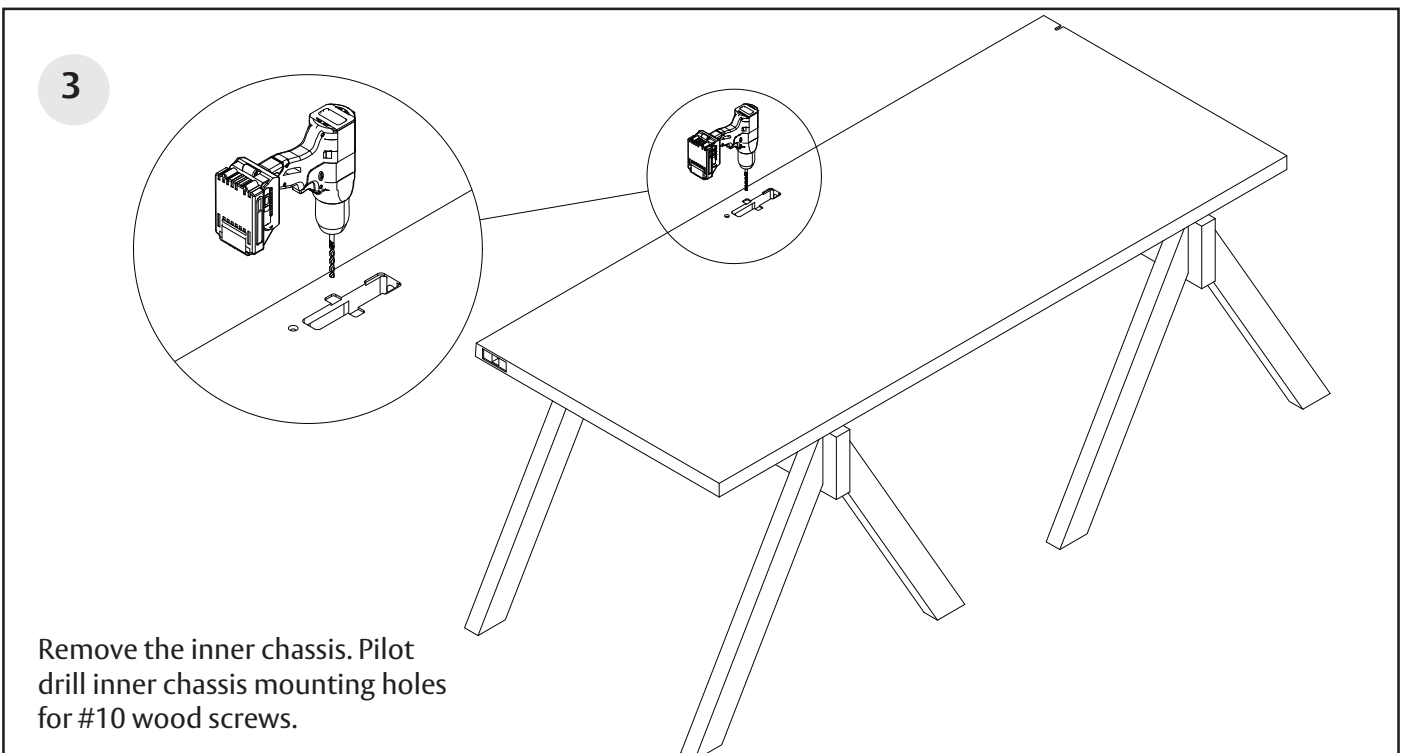
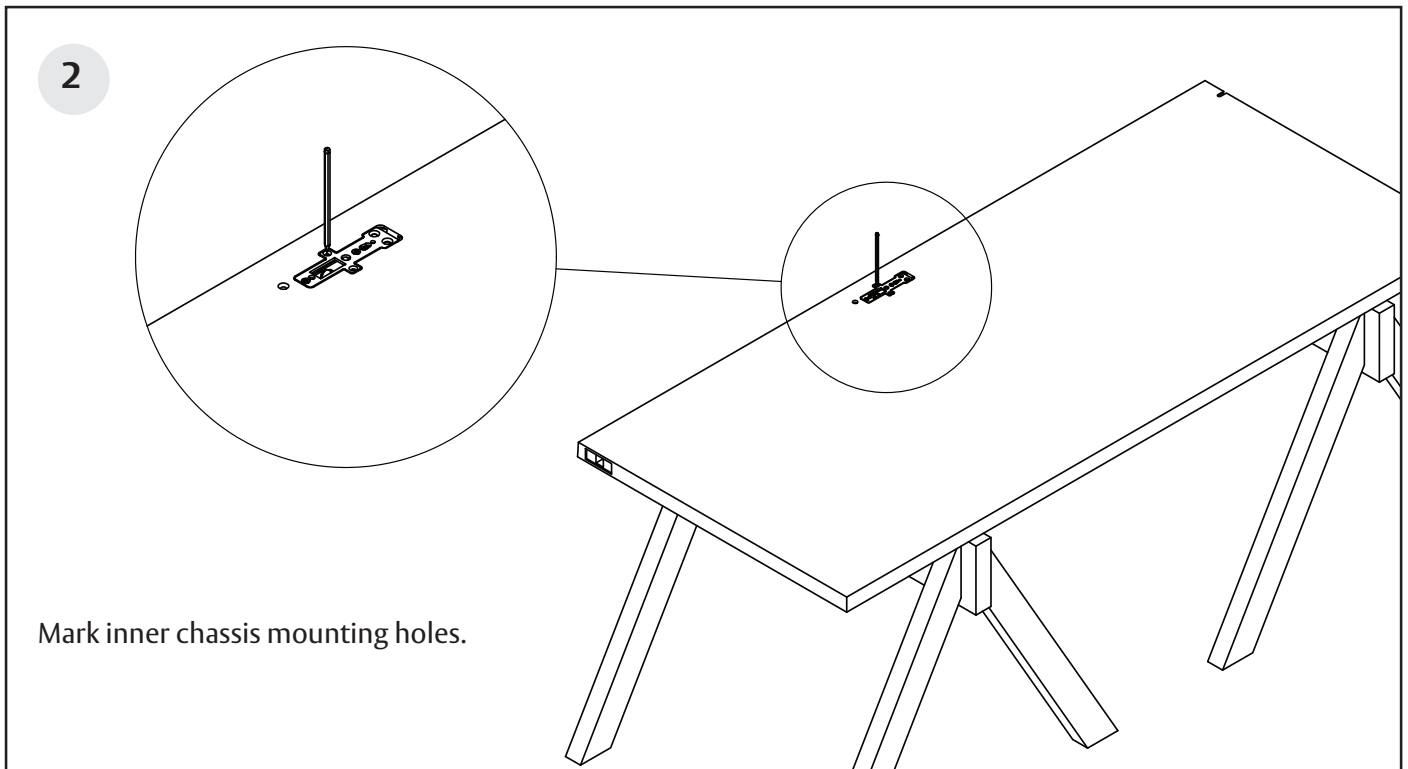

# PE8600 Series (12-WD, WD, NB-12-WD & NB-WD)

**SARGENT**

**ASSA ABLOY**

## Concealed Vertical Rod Exit Devices

### Installation Instructions

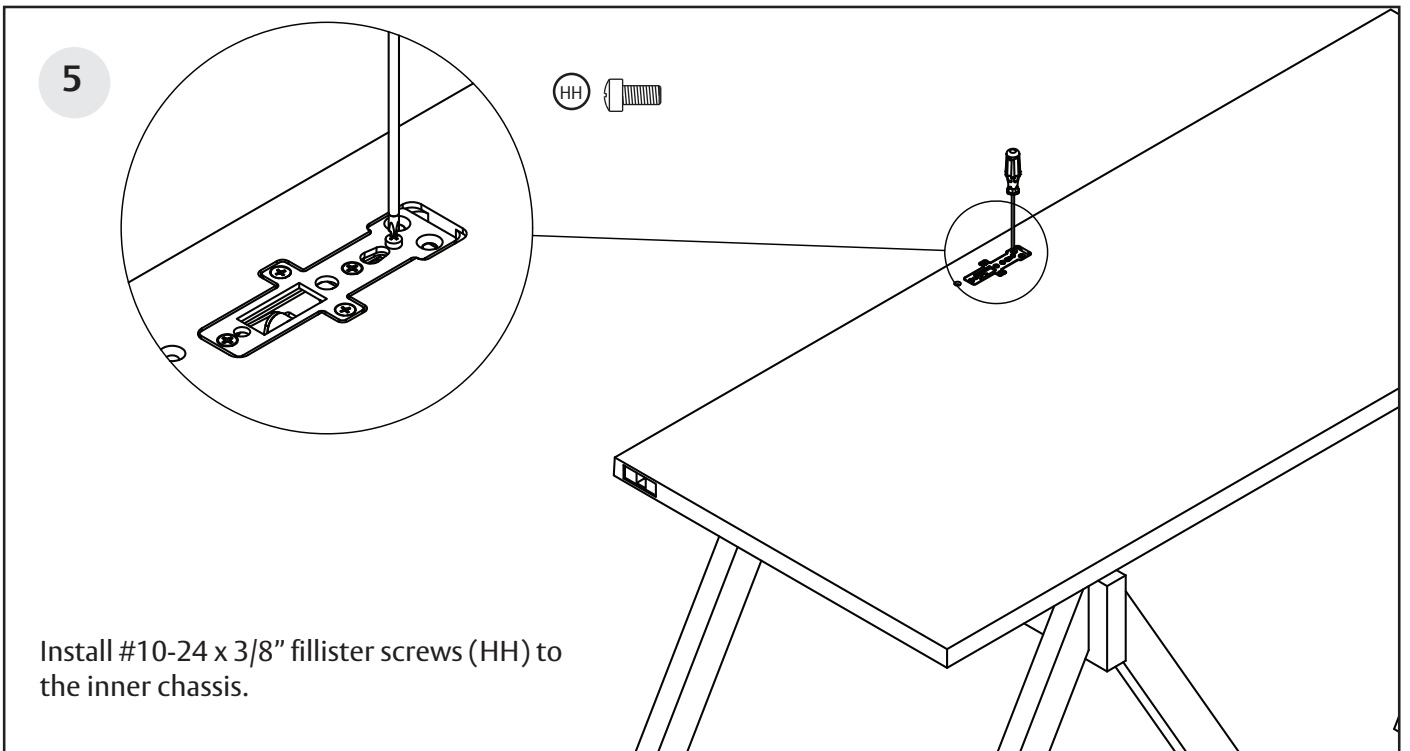
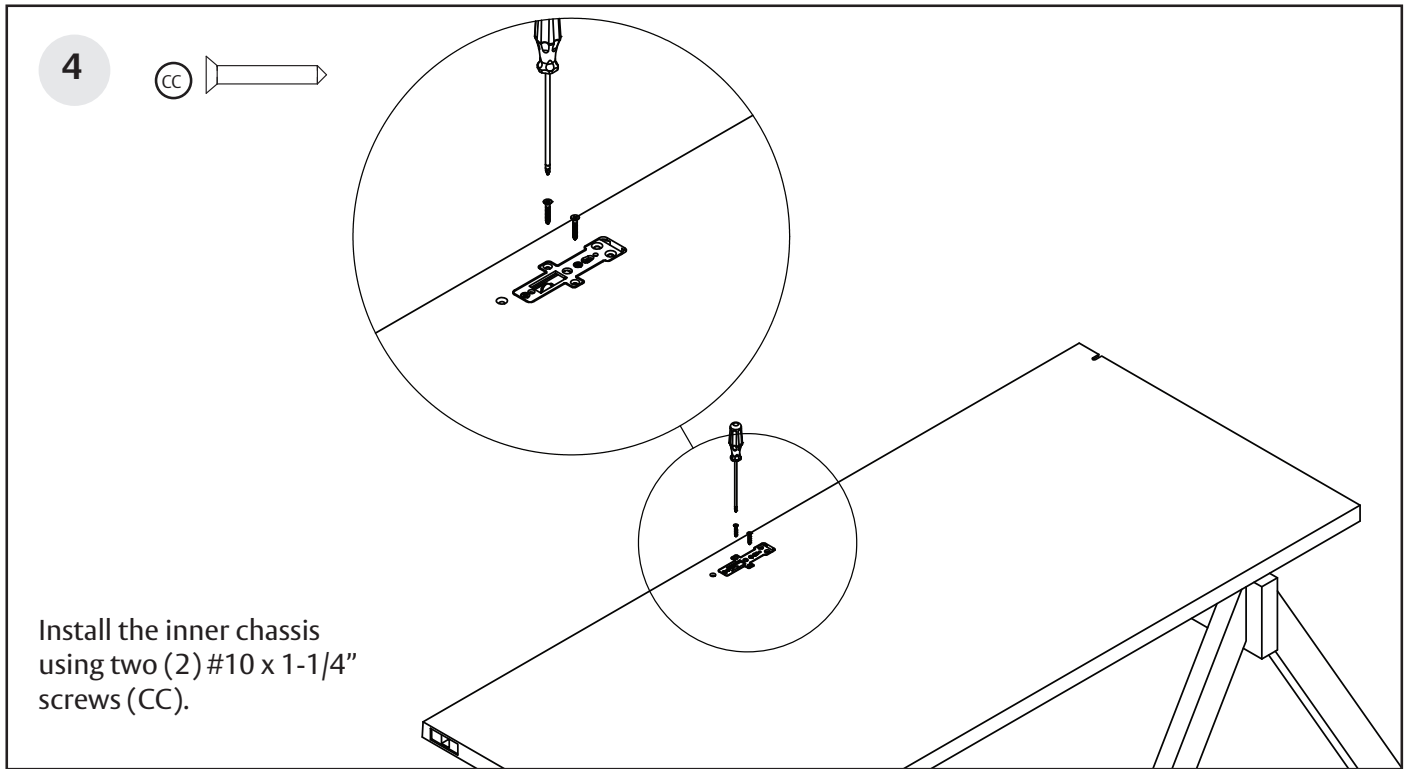

A8315-1 5/23

1-800-727-5477 • [www.sargentlock.com](http://www.sargentlock.com)

Copyright © 2023, SARGENT Manufacturing Company. All rights reserved. Reproduction in whole or in part without the express written permission of SARGENT Manufacturing Company is prohibited. Patent pending and/or patent [www.assaabloydss.com/patents](http://www.assaabloydss.com/patents).



Concealed Vertical Rod Exit Devices

Installation Instructions

6

- Slide top rod into the door and thread into the inner chassis.
- Ensure the teeth on the top bolt are facing opposite of the inside face of the door.

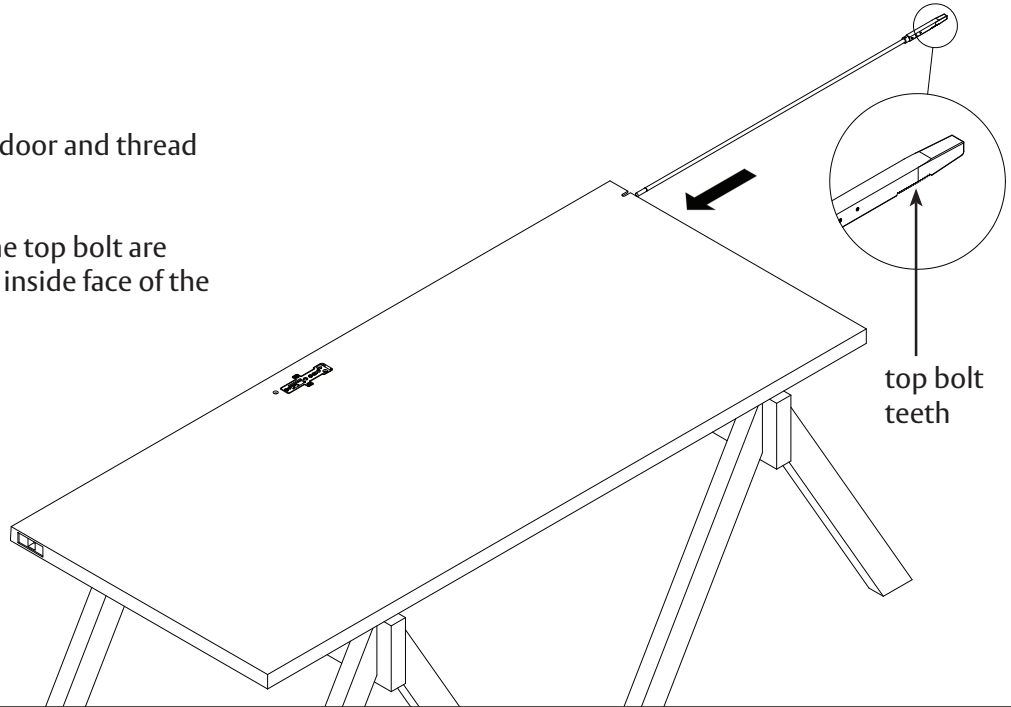

7

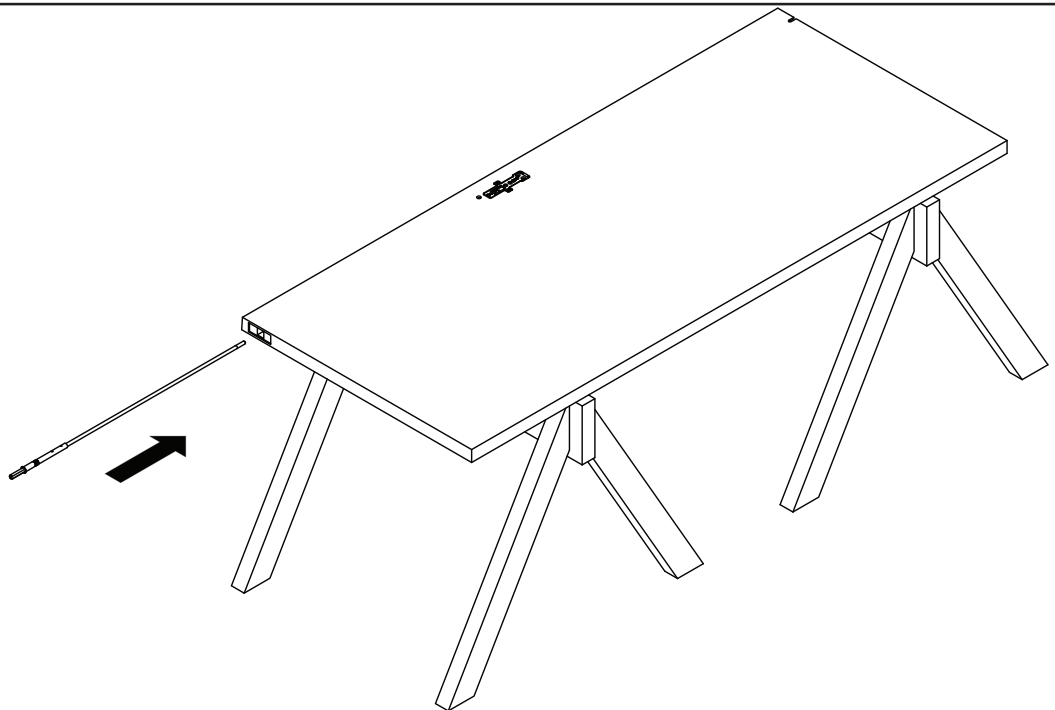

Slide bottom rod into the door and thread into the inner chassis.

# PE8600 Series (12-WD, WD, NB-12-WD & NB-WD)

**SARGENT**

**ASSA ABLOY**

## Concealed Vertical Rod Exit Devices

### Installation Instructions

8

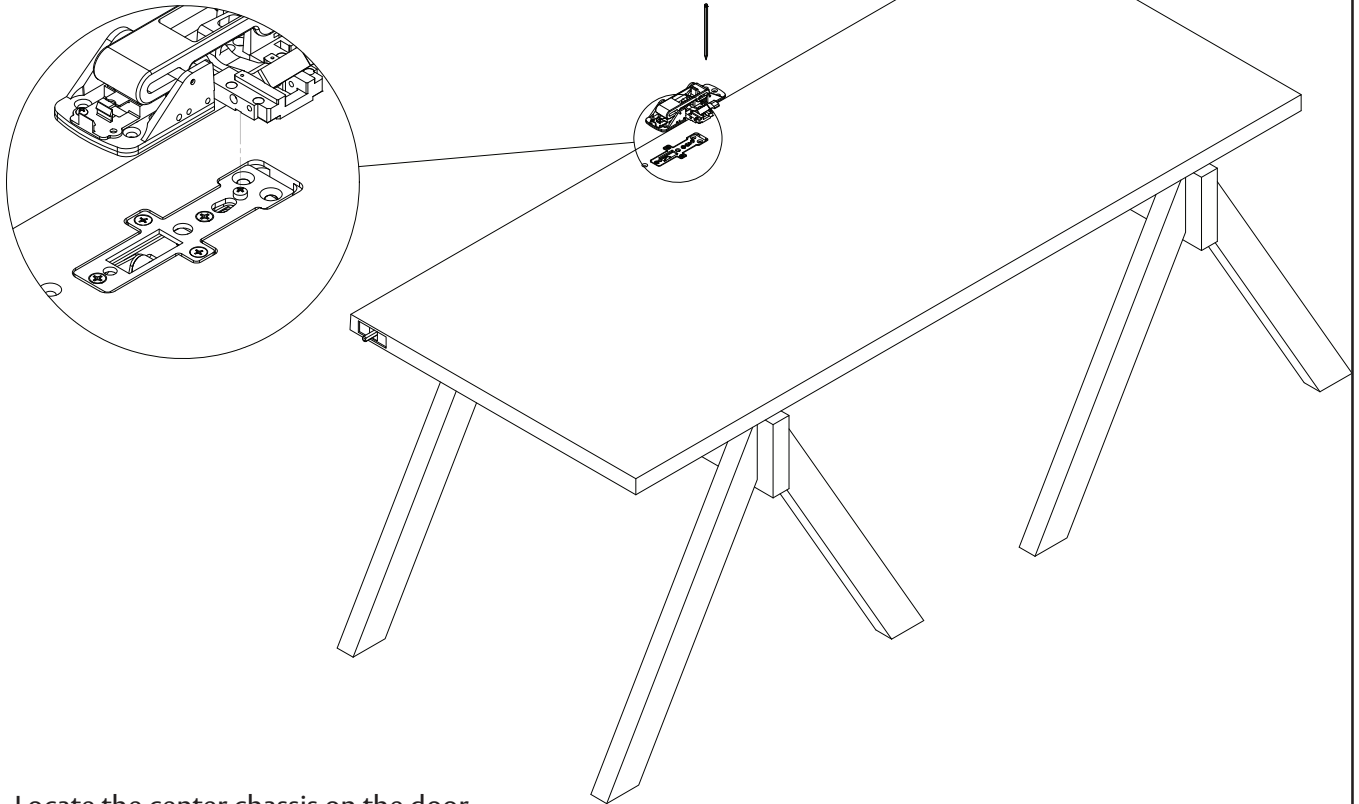

- Locate the center chassis on the door by keying it to the fillister head screw projecting off the door face.
- Mark the four corner mounting holes.

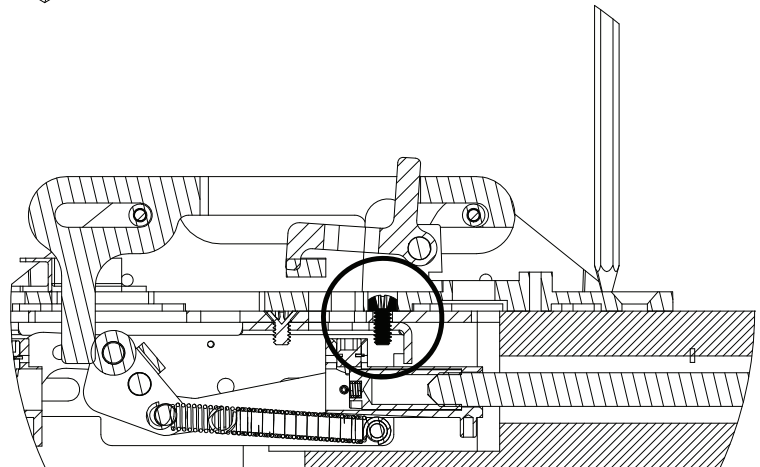

A8315-1 5/23

1-800-727-5477 • [www.sargentlock.com](http://www.sargentlock.com)

Copyright © 2023, SARGENT Manufacturing Company. All rights reserved. Reproduction in whole or in part without the express written permission of SARGENT Manufacturing Company is prohibited. Patent pending and/or patent [www.assaabloyds.com/patents](http://www.assaabloyds.com/patents).

## Concealed Vertical Rod Exit Devices

### Installation Instructions

9

Remove the center chassis from the door.  
Pilot mounting holes for a #10 wood screw.

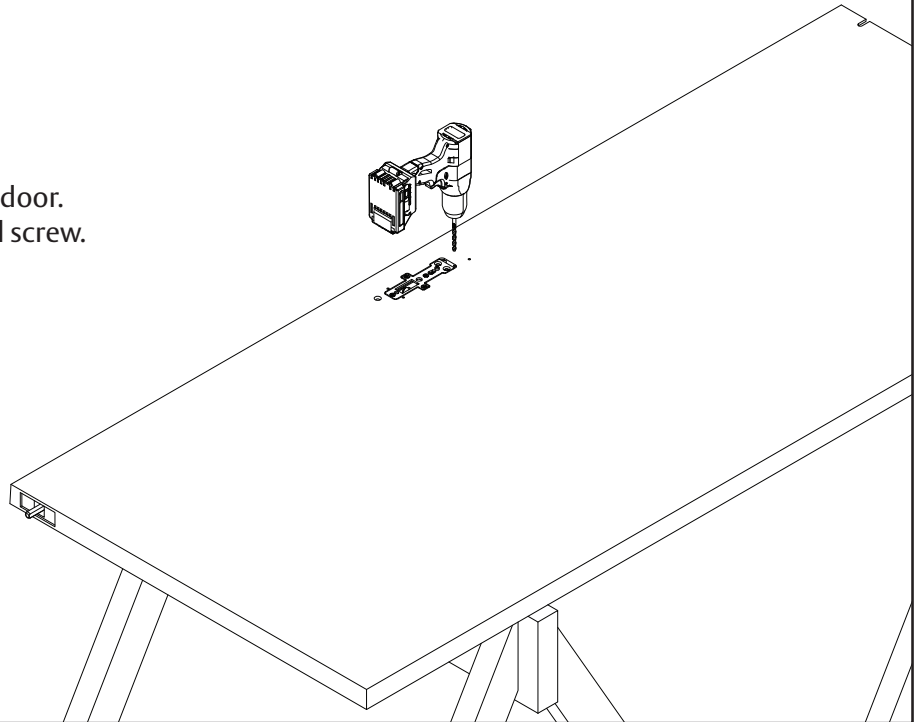

10

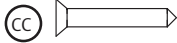

Install the center chassis using  
four (4) #10 x 1-1/4" screws  
(CC). **Do not fully tighten.**

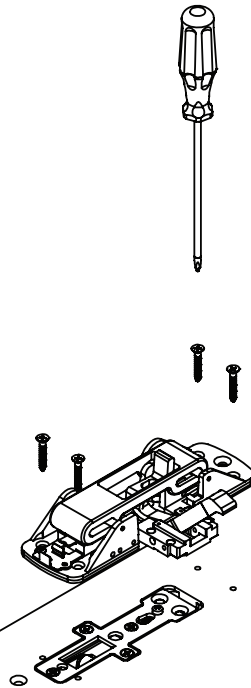

Concealed Vertical Rod Exit Devices

Installation Instructions

11

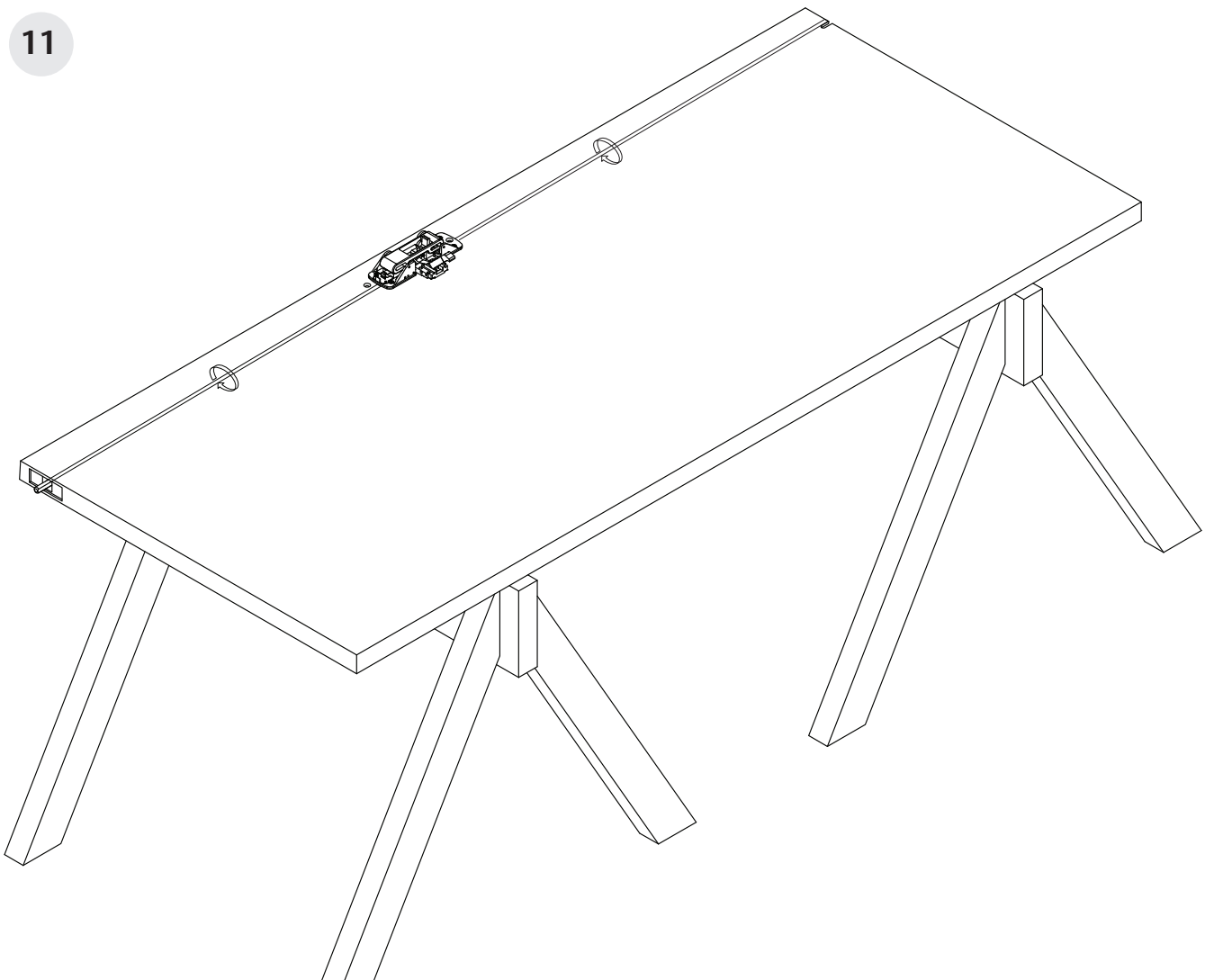

**Adjusting the top bolt and rod assembly**

- 1/8" gap or less between door top and frame: Rotate bolt to make it even with the top of the door.
- 1/8" gap or greater: Bolt must extend above the door, equal to the gap, minus 1/8".

**Adjusting the bottom bolt and rod assembly** (Not needed for NB exit devices)

- 1/8" gap or less between door bottom and high point: Rotate bolt to make it even with the top of the door.
- 1/8" gap or greater: Bolt must extend below the door, equal to the gap, minus 1/8".

**Note:** Rod must be retracted while adjusting bolt projection. Depress chassis lift arm to retract top bolt and rod assembly.

A8315-1 5/23

## Concealed Vertical Rod Exit Devices

### Installation Instructions

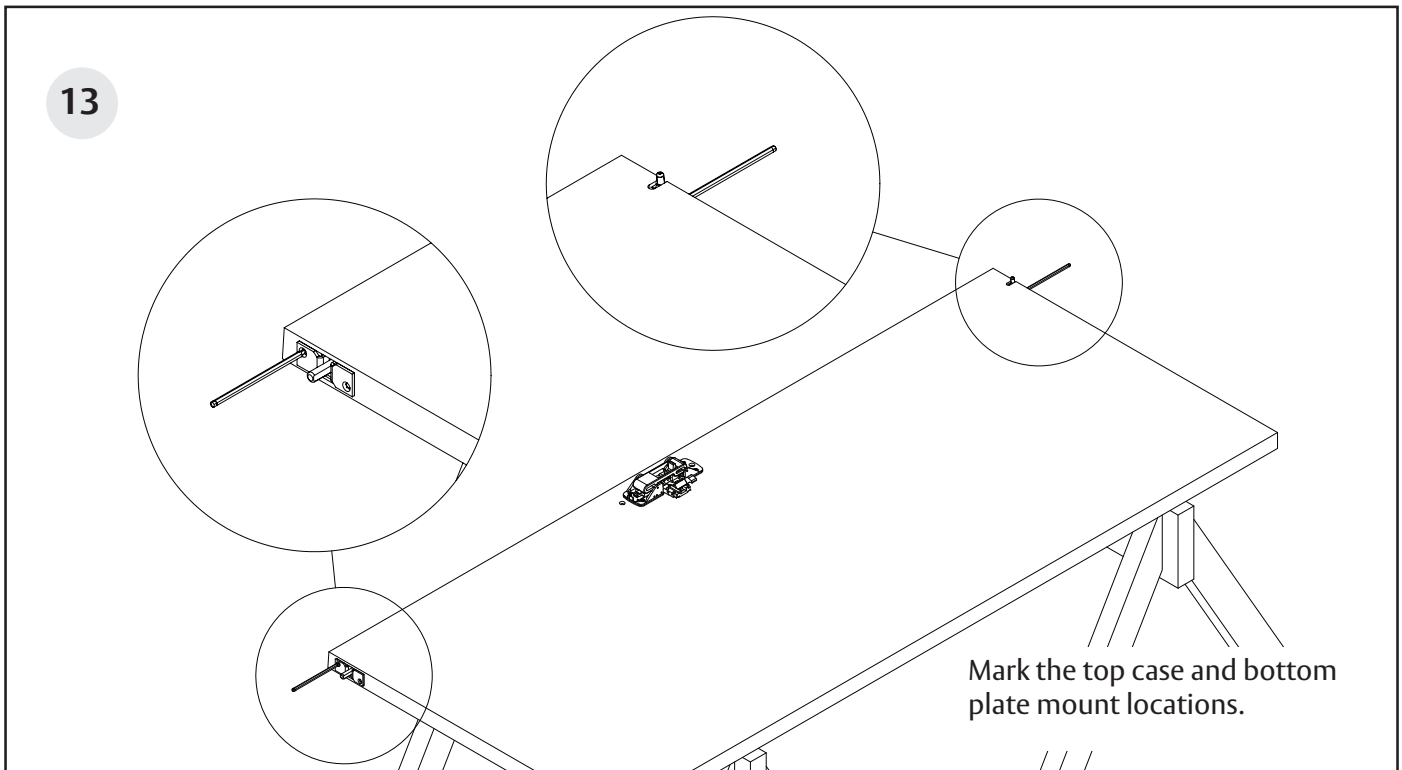
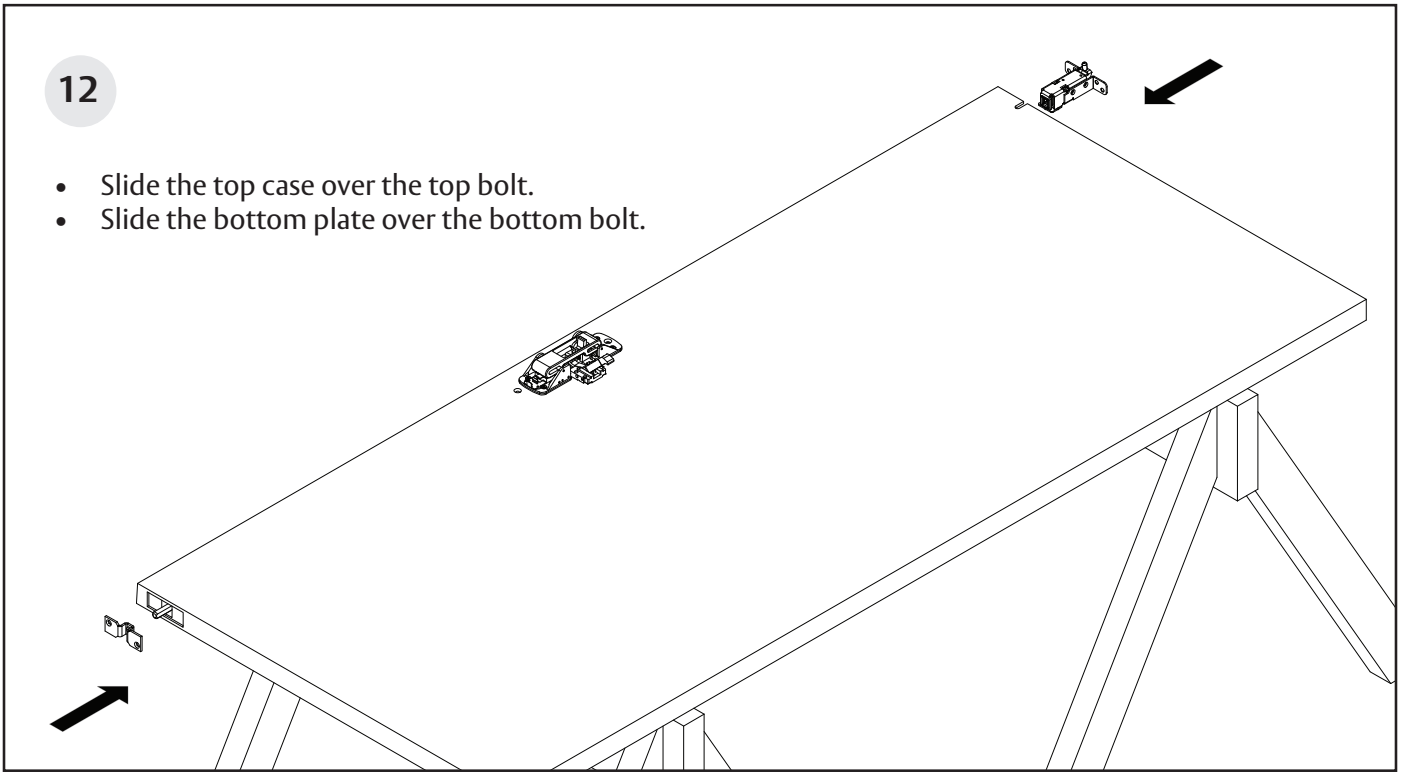

## Concealed Vertical Rod Exit Devices

### Installation Instructions

14

- Remove the top case and bottom plate.
- Pilot drill the top case holes for #12 wood screws.
- Pilot drill the bottom plate holes for 1/4" wood screws

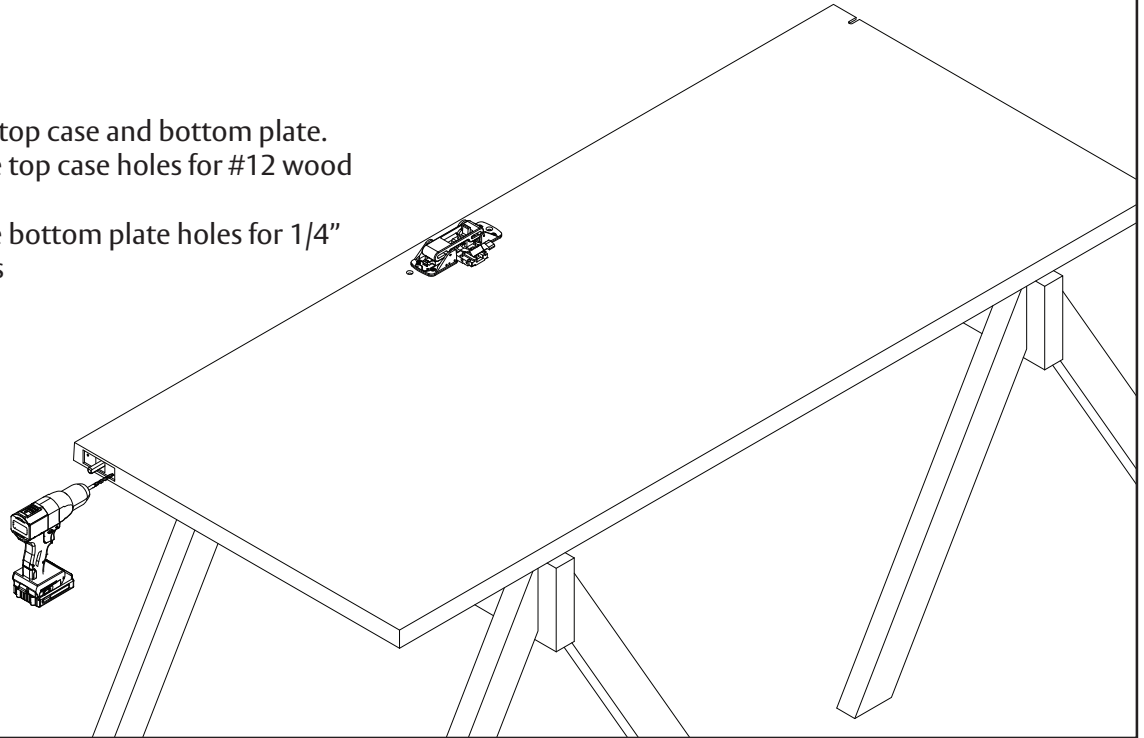

15

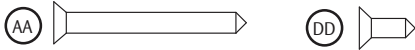

- Slide the top case over the top bolt. Secure to the top of the door with (4) #12 x 2" wood screws (AA).
- Install the bottom plate over the bottom bolt. Secure with (2) 1/4" x 1/2" wood screws (DD).

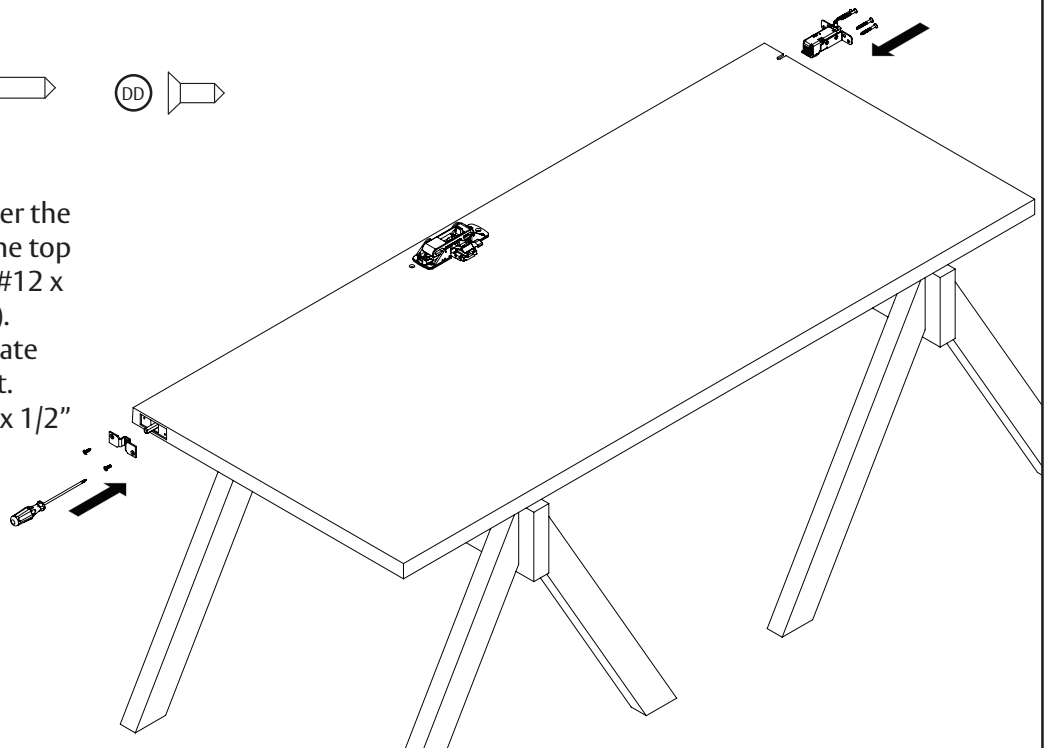

A8315-1 5/23

## Concealed Vertical Rod Exit Devices

### Installation Instructions

16

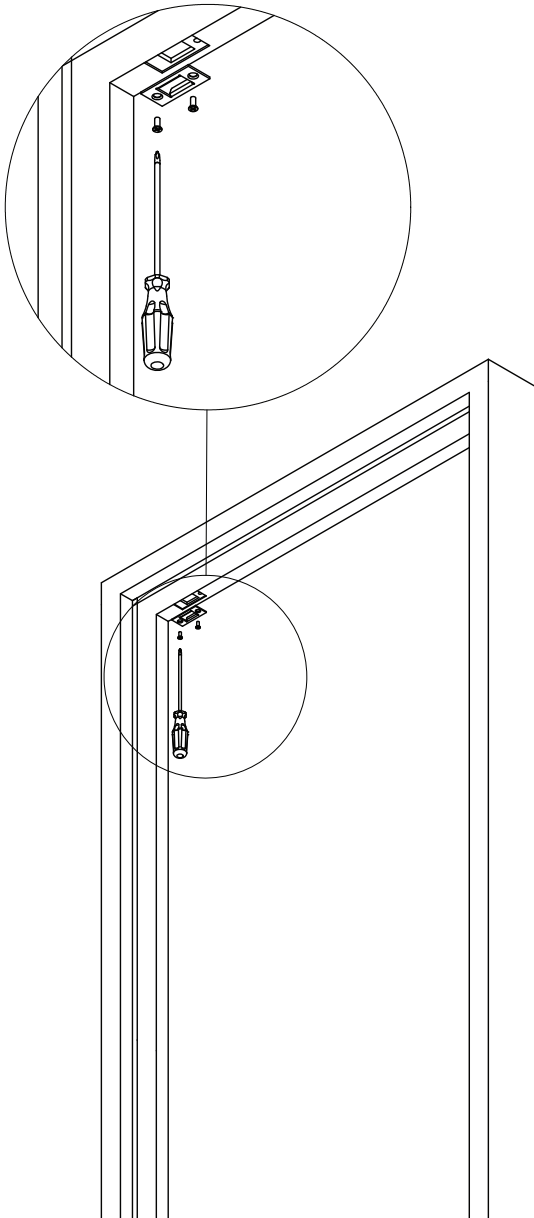

- Attach 650 strike to frame with (2) #10-24 x 1/2" flat head screws.

# PE8600 Series (12-WD, WD, NB-12-WD & NB-WD)

**SARGENT**

**ASSA ABLOY**

## Concealed Vertical Rod Exit Devices

### Installation Instructions

17

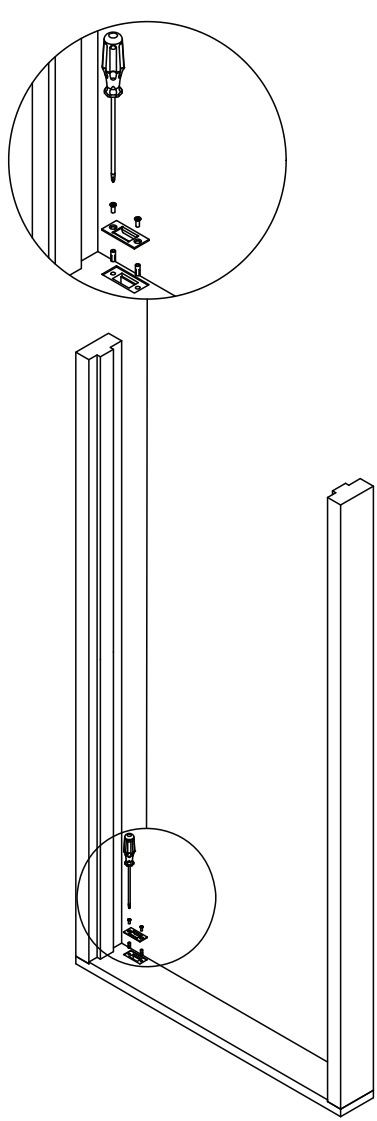

- For WD-PE8600: Attach 650 bottom strike to floor with anchors and supplied fasteners.
- For 12-WD-PE8600 attach 606 bottom strike to floor with anchors and supplied fasteners.

18

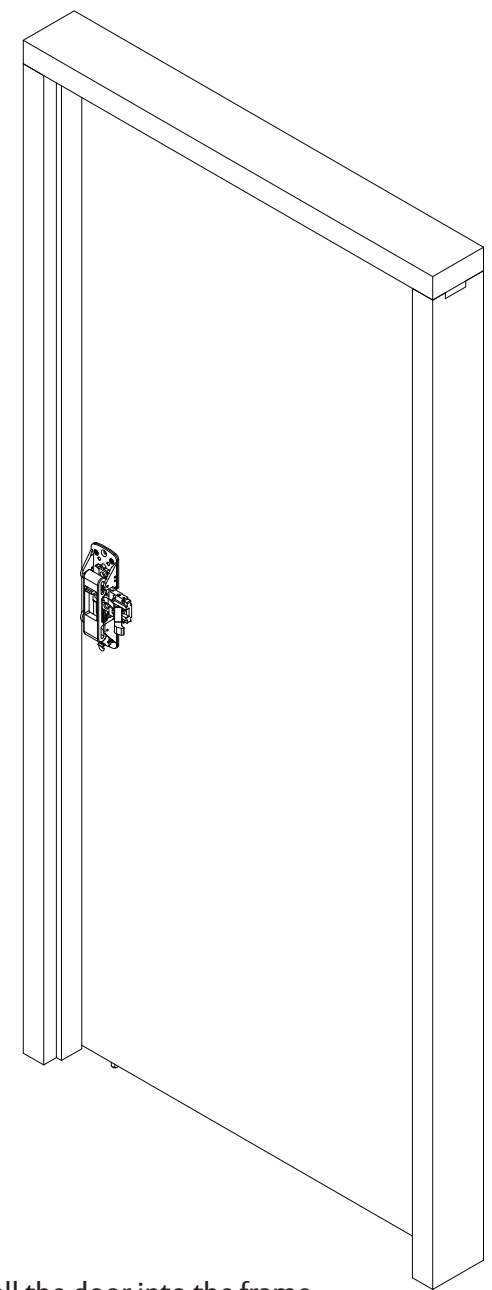

Reinstall the door into the frame.



# PE8600 Series (12-WD, WD, NB-12-WD & NB-WD)

**SARGENT**

**ASSA ABLOY**

## Concealed Vertical Rod Exit Devices

### Installation Instructions

#### Rail cutting guide

If the rail doesn't need to be cut, continue to page 18 step 19.

If the rail must be cut, follow these steps on page 16 and 17:

Refer to the individual exit device installation instructions for rail cutting requirements / restrictions. Instructions will vary based on device type and options.

- Determine cut off dimension "X" by subtracting 2-7/8" from dimension "Y". Mark cut off point on mounting rail. (See below.)

 Do not cut closer than 1-5/8" from the the front edge of the rail insert.

Information for Cutting Rails		
Rail Sizes	Door Widths	
	Standard	Minimum
E	32"	24"
F	36"	33"
J	42"	37"
G	48"	43"

Verticle reference line (C of chassis)

For doors with stile rail, the stile must overlap by 5/16" min.

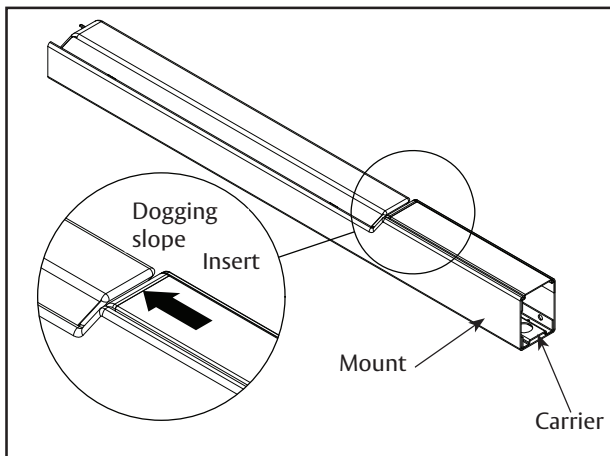
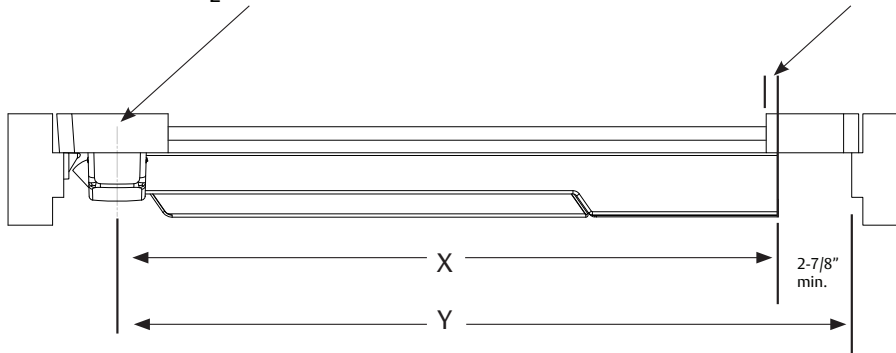

A. Ensure there isn't a gap between the insert and the dogging slope, and the carrier is flush with the mount.

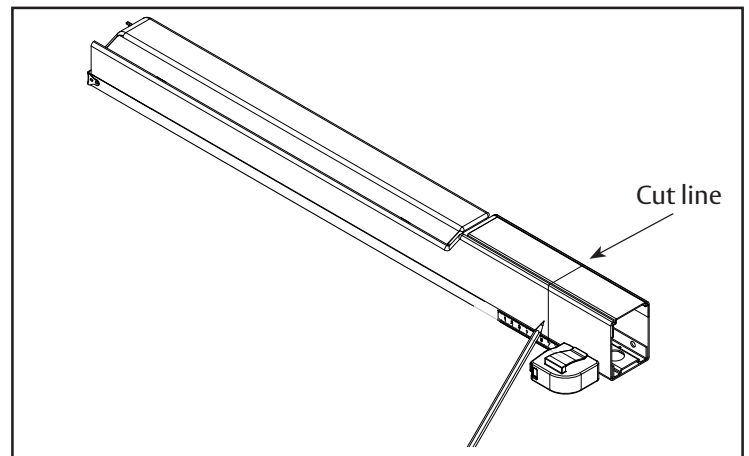

B. Mark rail at the required cut length.

# PE8600 Series (12-WD, WD, NB-12-WD & NB-WD)

**SARGENT**

**ASSA ABLOY**

## Concealed Vertical Rod Exit Devices

### Installation Instructions

### Rail cutting guide, continued.

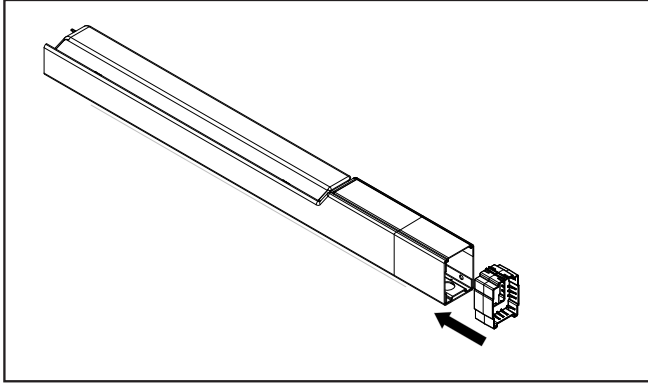

C. Ensure plastic insert support is installed under the cut line.

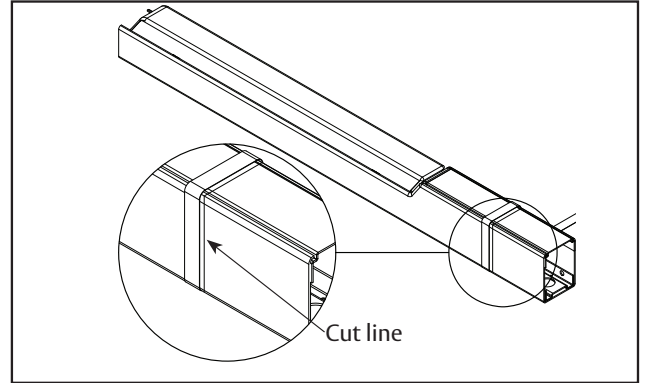

D. Wrap the rail and insert in masking tape, as shown.

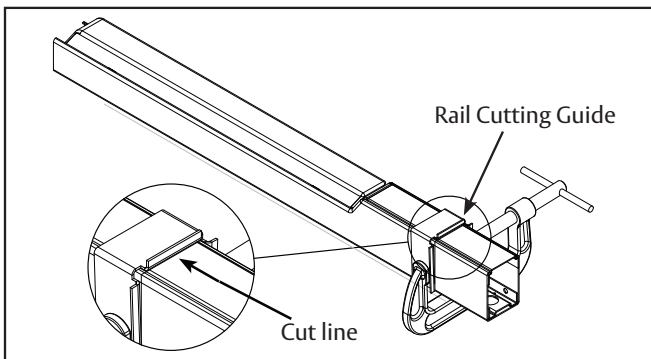

E. Place the rail cutting guide over the masking tape and align it with the cut line. Clamp the cut guide to the rail using a C-clamp.

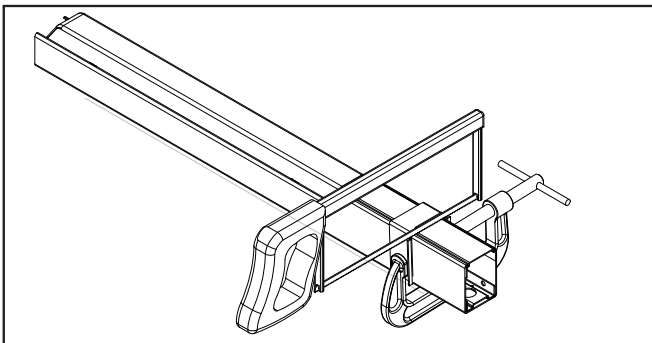

F. Using a hack saw with a new blade or a chop saw with a metal cutting blade, cut the rail, ensuring that the blade stays pressed against the rail cutting guide.

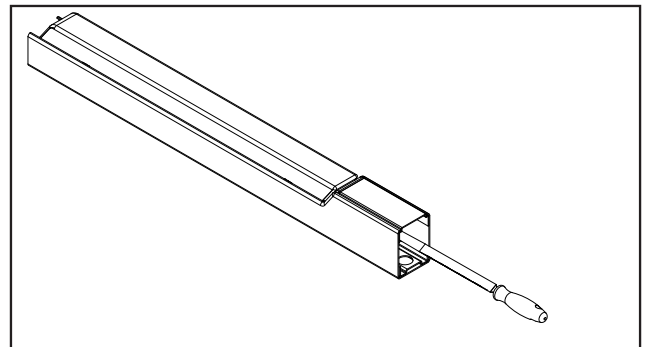

G. Deburr and smooth all cut edges with a file.

Concealed Vertical Rod Exit Devices

Installation Instructions

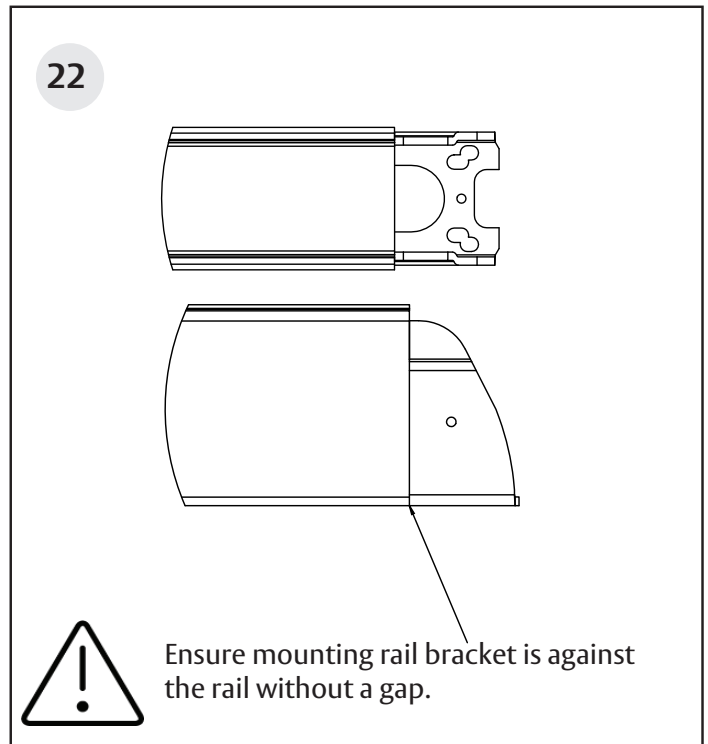
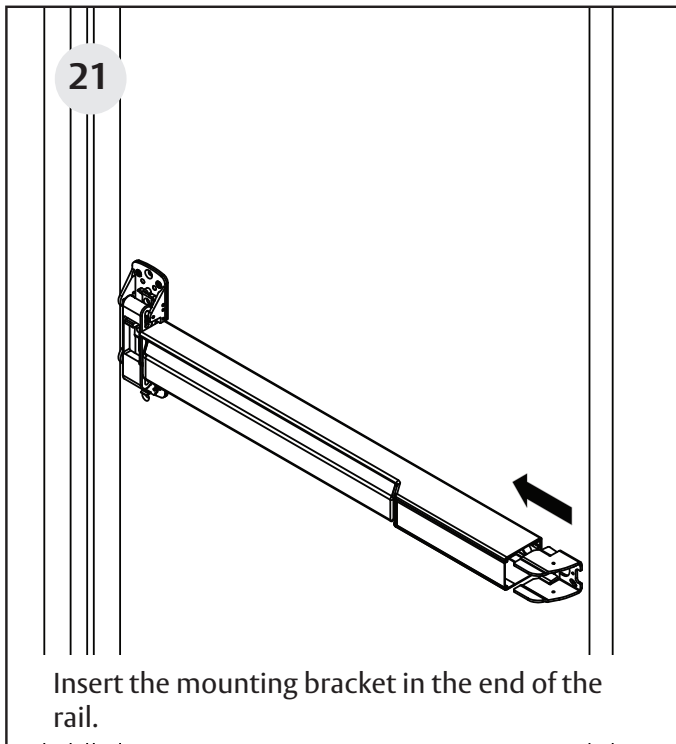
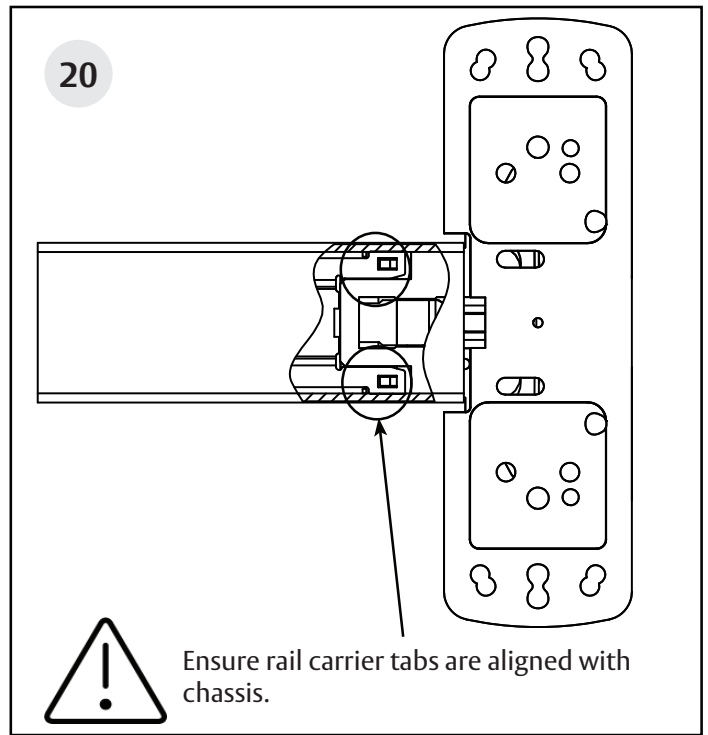
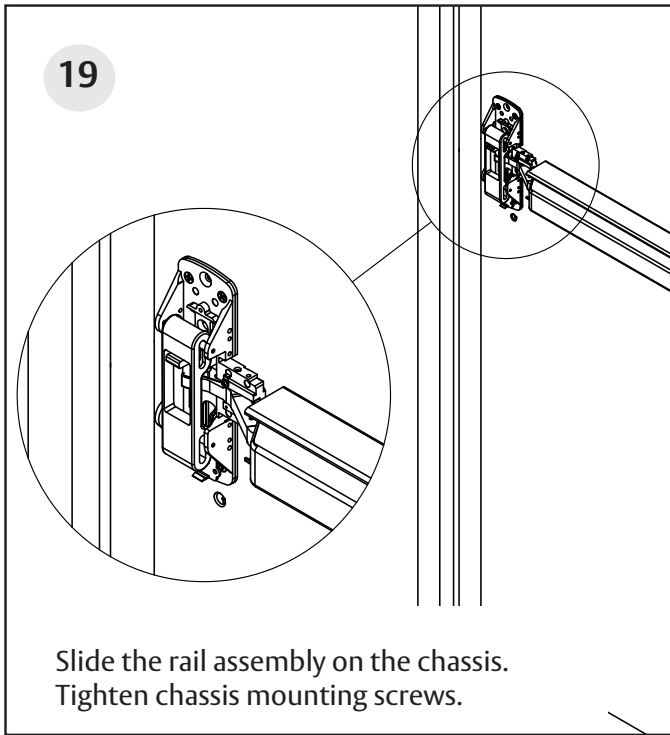

# PE8600 Series (12-WD, WD, NB-12-WD & NB-WD)

**SARGENT**

**ASSA ABLOY**

## Concealed Vertical Rod Exit Devices

### Installation Instructions

23

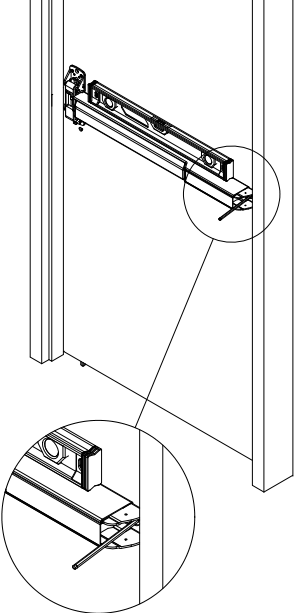

Level the rail and mark mounting holes, using the bracket as a guide.

24

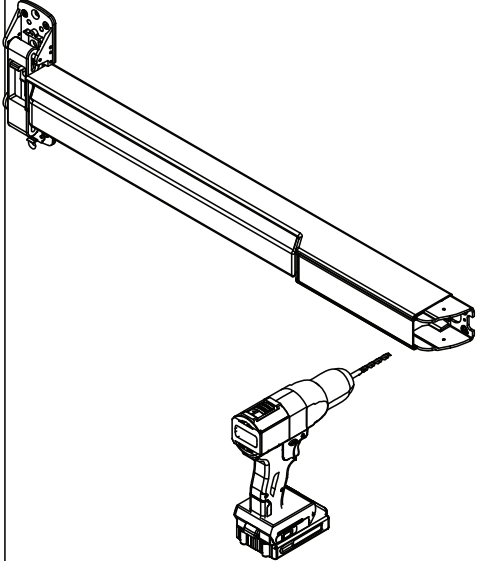

Pilot mounting bracket holes for #10 wood screws.

25

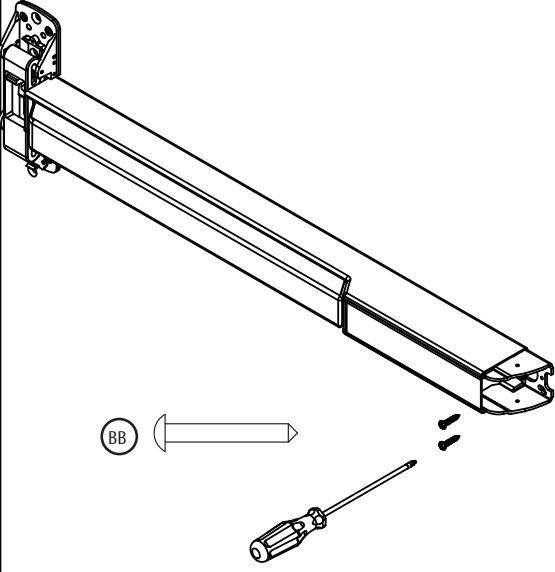

Attach mounting bracket with (2) #10 wood screws (BB).

Concealed Vertical Rod Exit Devices

Installation Instructions

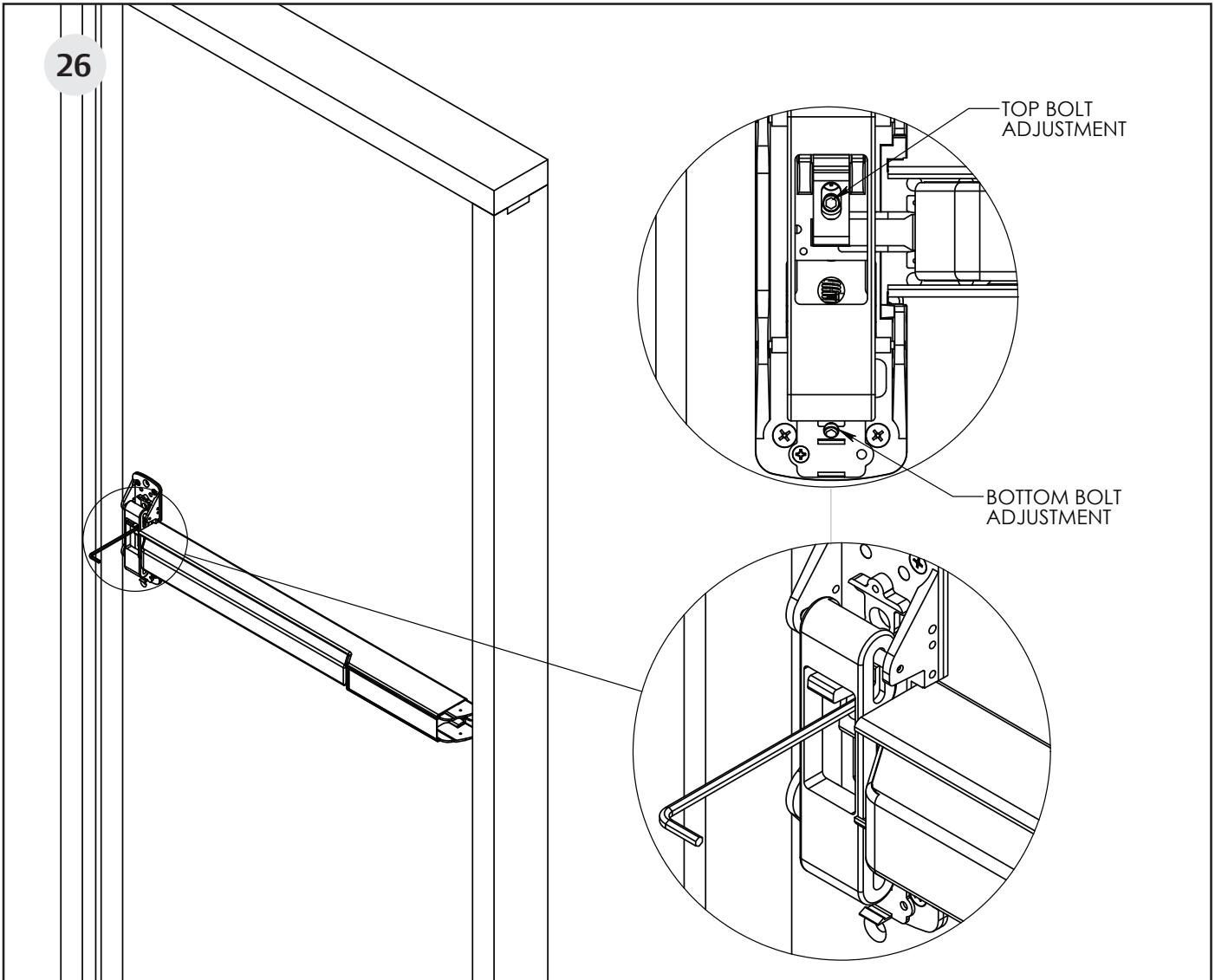

If adjustments are needed, before closing the door check the following:

- Push rail in to retract bolts.
- Bolts stay retracted (hold back).
- Bolts release when the door closes. The button inside the top of the door hits the frame.
- The bolt engages with the strike 1/4" - 5/16".

For final adjustment close door to adjust.

- Use 5/32" Allen wrench to adjust projection. Turn clockwise to adjust the bolt back into the door. Turn counter clockwise to extend the bolt.

# PE8600 Series (12-WD, WD, NB-12-WD & NB-WD)

**SARGENT**

## Concealed Vertical Rod Exit Devices

**ASSA ABLOY**

### Installation Instructions

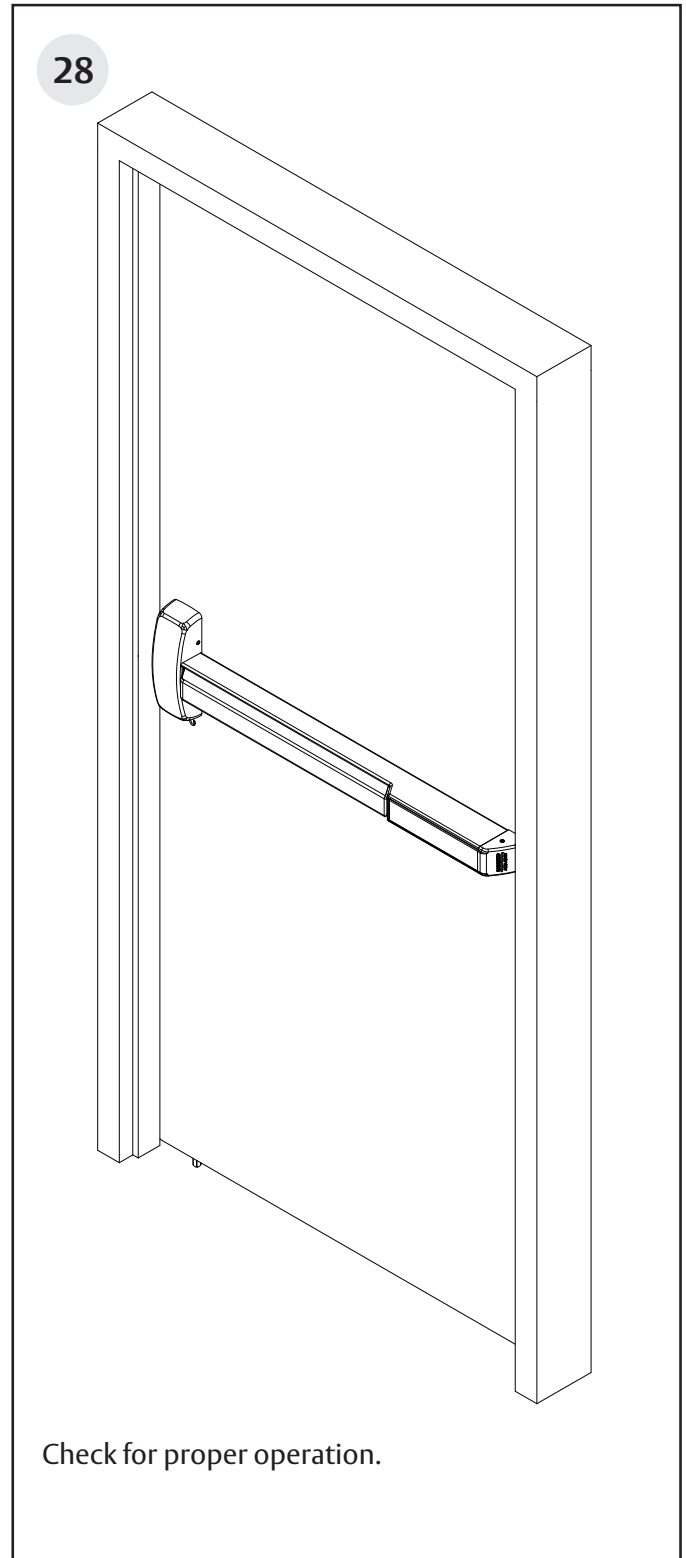
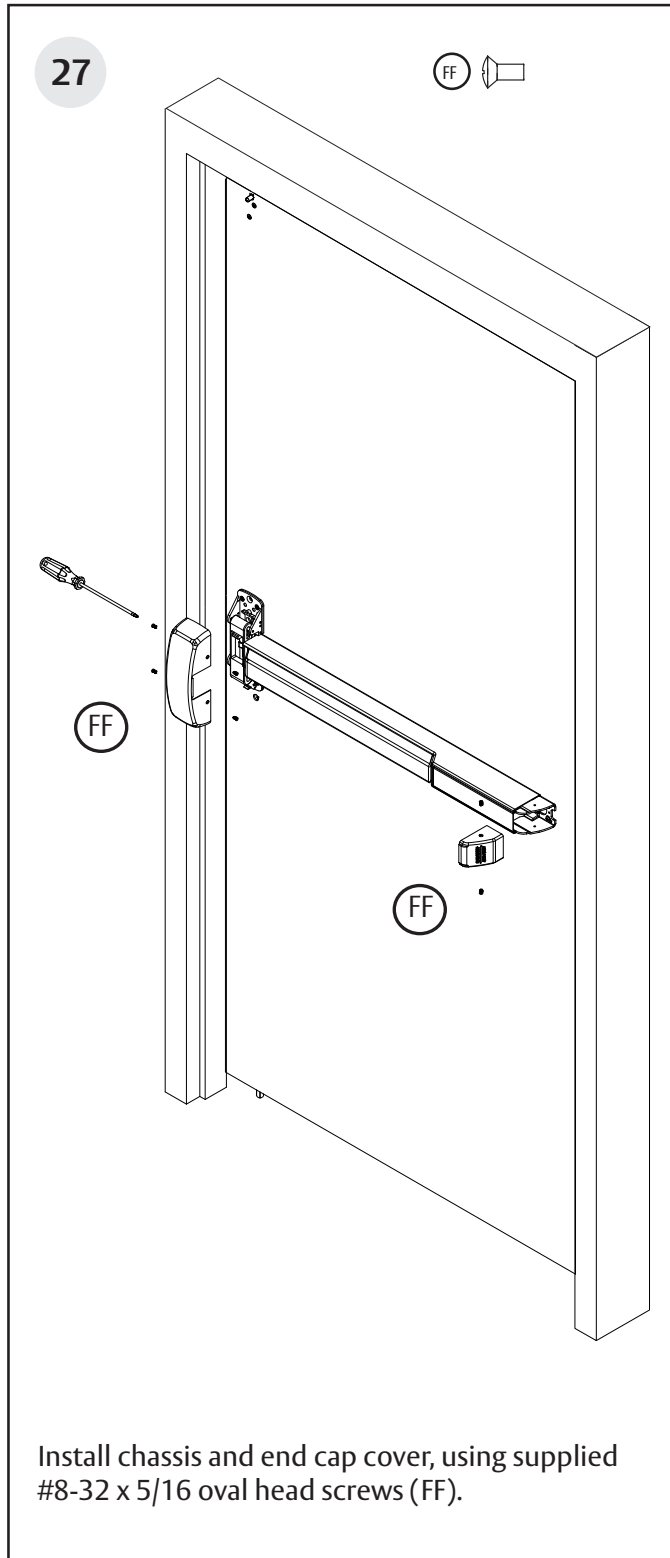

A8315-1 5/23

1-800-727-5477 • [www.sargentlock.com](http://www.sargentlock.com)

Copyright © 2023, SARGENT Manufacturing Company. All rights reserved. Reproduction in whole or in part without the express written permission of SARGENT Manufacturing Company is prohibited. Patent pending and/or patent [www.assaabloydss.com/patents](http://www.assaabloydss.com/patents).

# PE8600 Series (12-WD, WD, NB-12-WD & NB-WD)

## Concealed Vertical Rod Exit Devices

### Installation Instructions



