

# Installation Instructions

**SARGENT**  
**ASSA ABLOY**

## PE8500 Series - Narrow Rim Exit Devices

For Standard, Fire Rated and Aluminium Doors

PE8500 - Standard

12-PE8500 - Fire Rated

AD-PE8500 - Aluminum Door

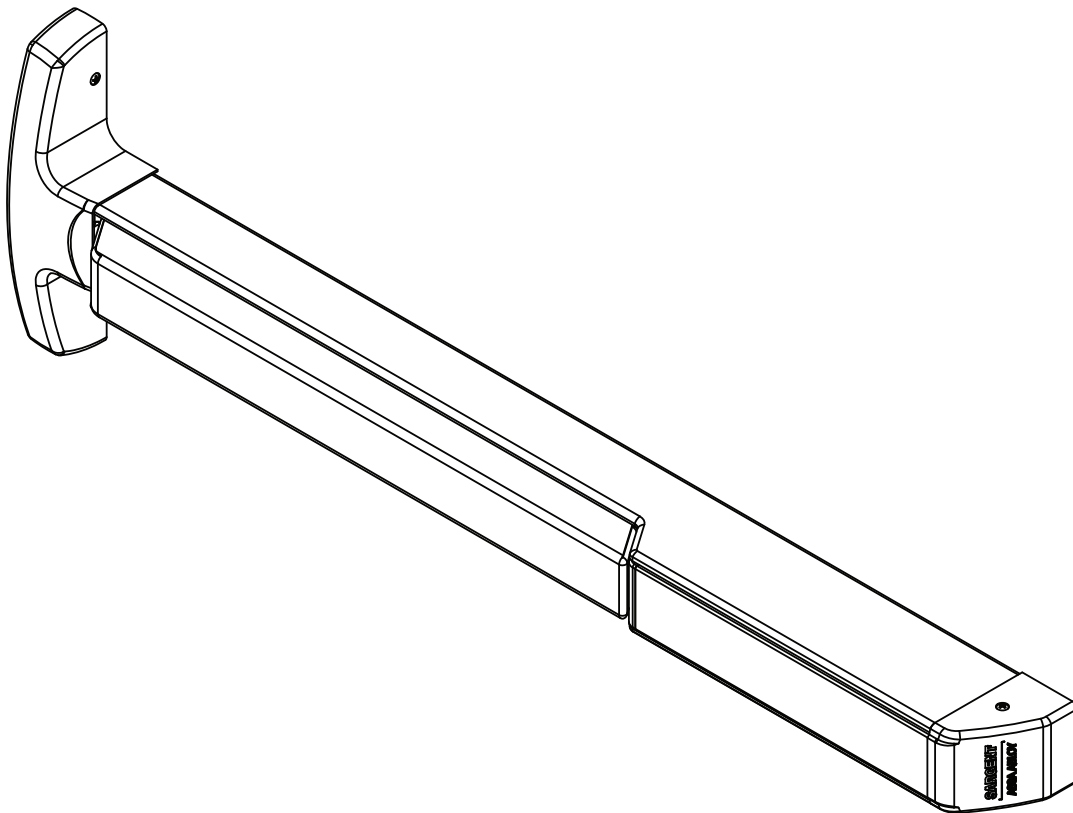

### **WARNING**

This product can expose you to lead which is known to the state of California to cause cancer and birth defects or other reproductive harm. For more information go to [www.P65warnings.ca.gov](http://www.P65warnings.ca.gov).

### **WARNING**

Attention Installer: Improper installation may result in damage to the product and void the factory warranty.

1-800-727-5477 • [www.sargentlock.com](http://www.sargentlock.com)

Copyright © 2023, SARGENT Manufacturing Company. All rights reserved. Reproduction in whole or in part without the express written permission of SARGENT Manufacturing Company is prohibited. Patent pending and/or patent [www.assaabloydss.com/patents](http://www.assaabloydss.com/patents).

A8302-1 5/23

Experience a safer  
and more open world

# PE8500 Series - Narrow Rim Exit Devices







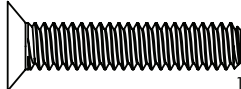
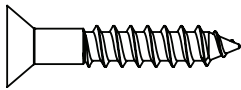

**SARGENT**

**ASSA ABLOY**

For Standard, Fire Rated and Aluminium Doors

## Installation Instructions

### Screw Chart

SCREW	TOTAL QTY SUPPLIED	WHERE USED
 1/4"-20 X 1-1/4" FLAT HEAD MACHINE SCREW	2	(2) CHASSIS OUTER MOUNTING HOLES (METAL DOOR)
 #12 X 1-1/4" FLAT HEAD WOOD SCREW	2	(2) CHASSIS OUTER MOUNTING HOLES (WOOD DOOR)
 #10-24 X 1-1/2" OVAL HEAD MACHINE SCREW	2	(2) CHASSIS INNER MOUNTING HOLES (METAL DOOR, FIRE RATED)
 #10-24 X 3/4" ROUND HEAD MACHINE SCREW	2	(2) REAR MOUNTING PLATE (METAL DOOR)
 #10 X 1-1/4" ROUND HEAD WOOD SCREW	2	(2) REAR MOUNTING PLATE (WOOD DOOR)
 #10-24 X 3/4" OVAL HEAD MACHINE SCREW	2	(2) 657 STRIKE (METAL FRAME)
 #10 X 1-1/4" OVAL HEAD WOOD SCREW	2	(2) 657 STRIKE (WOOD FRAME)
 #8-32 X 5/16" W/ #6 OVAL HEAD MACHINE SCREW	6	(4) CHASSIS COVER (2) END CAP
 1/4"-20 X 2-3/8" KNURLED FLAT HEAD MACHINE SCREW	2	(2) EXIT TRIM (IF USED)

# PE8500 Series - Narrow Rim Exit Devices

For Standard, Fire Rated and Aluminium Doors

**SARGENT**

**ASSA ABLOY**

## Installation Instructions

### Tools Needed

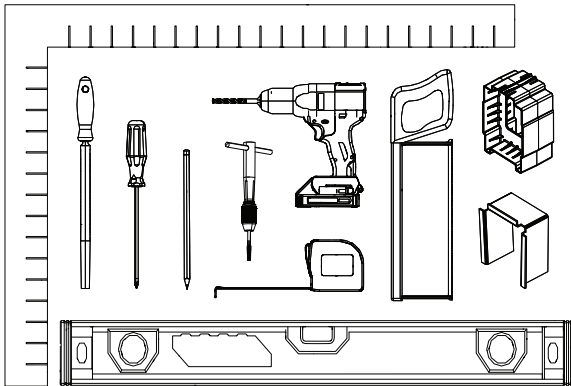

Support Block (Provided)

Rail Cutting Guide (Provided)

### Exploded View

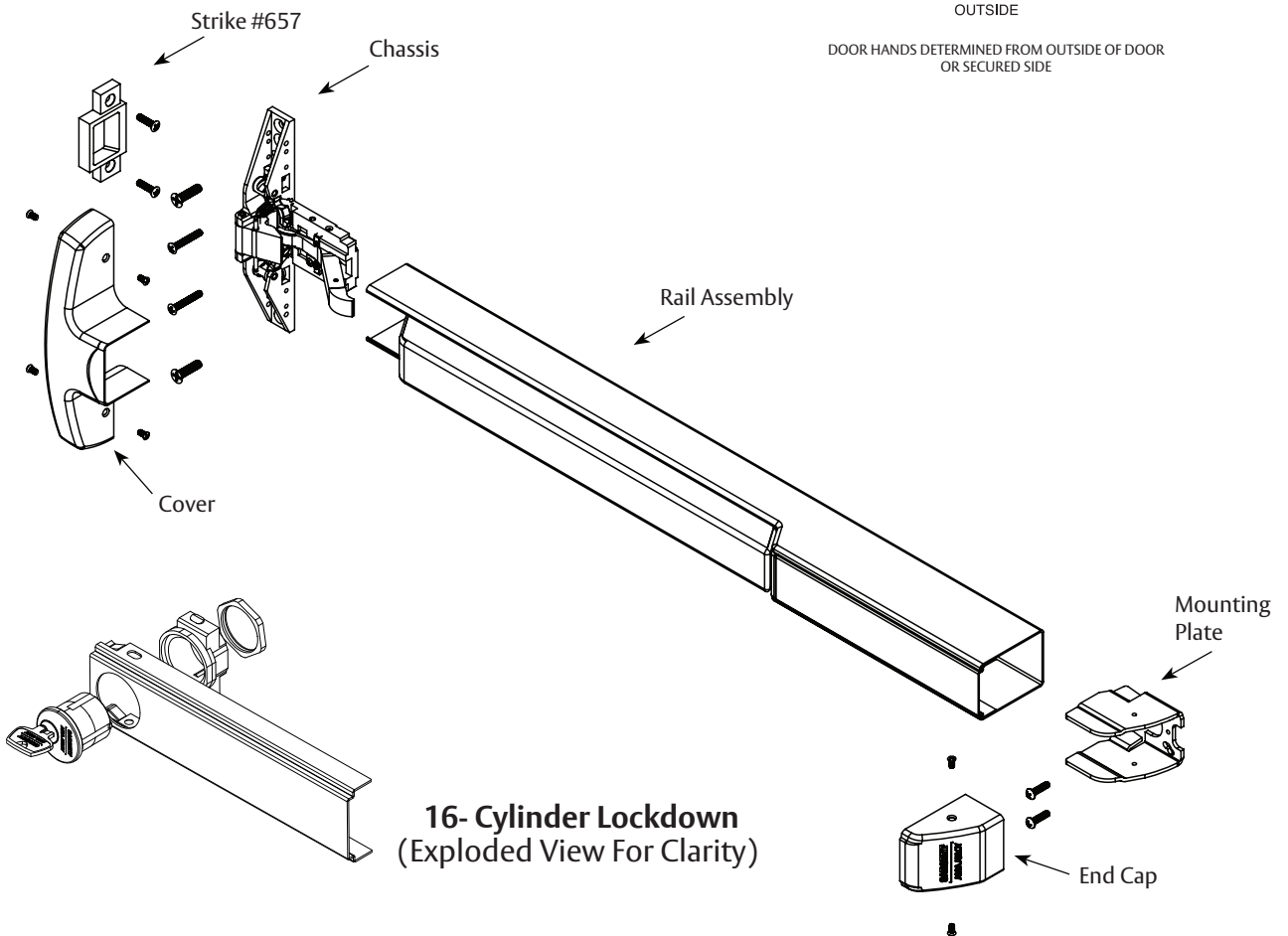

**16-Cylinder Lockdown**  
(Exploded View For Clarity)

# PE8500 Series - Narrow Rim Exit Devices

For Standard, Fire Rated and Aluminium Doors

**SARGENT**

**ASSA ABLOY**

## Installation Instructions



### Before installation:

1. Install mullion, if used.
2. Fit and hang door.
3. Check the box's label for the size of the exit device.
4. For wood doors, use wood screws and prep accordingly.



The surface of the door where the exit device is to be applied must be flush. Clear away any raised projections to allow exit device to rest on the flat surface of the door. If shim kit is required, contact your distributor.

Note: Please refer to trim and other installation instructions provided in the box.

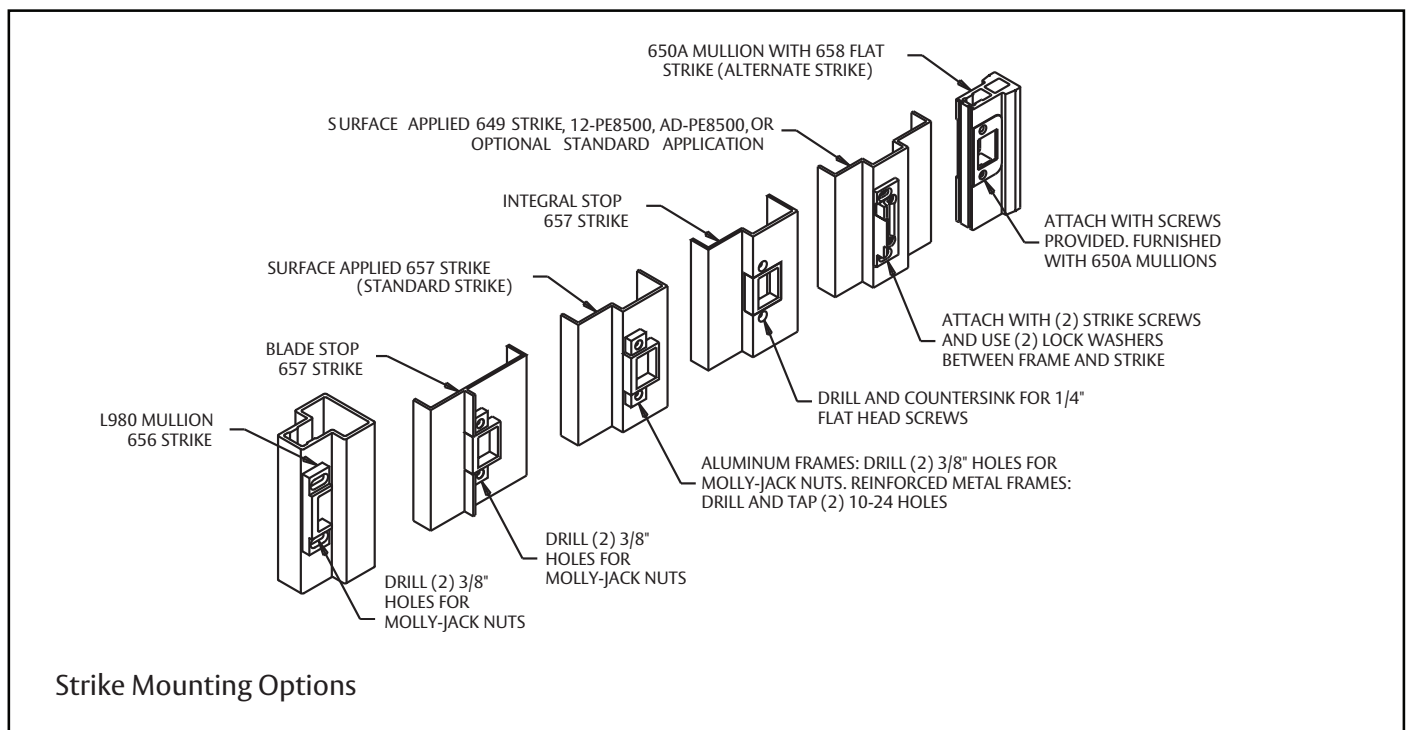

# PE8500 Series - Narrow Rim Exit Devices

For Standard, Fire Rated and Aluminium Doors

**SARGENT**

**ASSA ABLOY**

## Installation Instructions

**1**

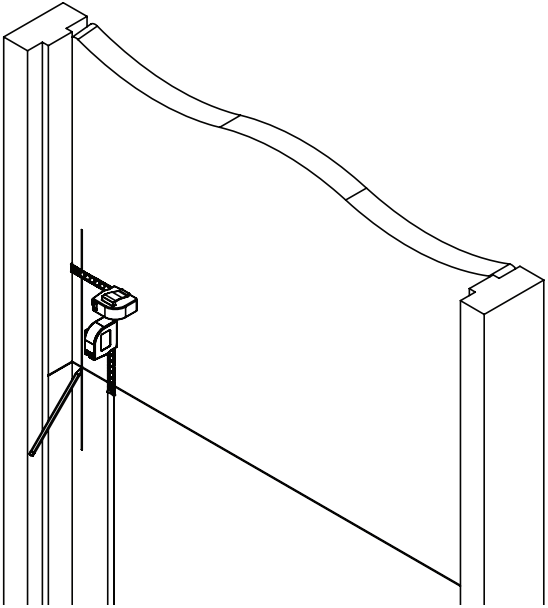

Measure 39-5/8" from the finished floor and mark door and frame. Temporarily hold strike against frame. Measure 13/16" from surface of strike (Refer to the strike template.) for vertical centerline.

**2**

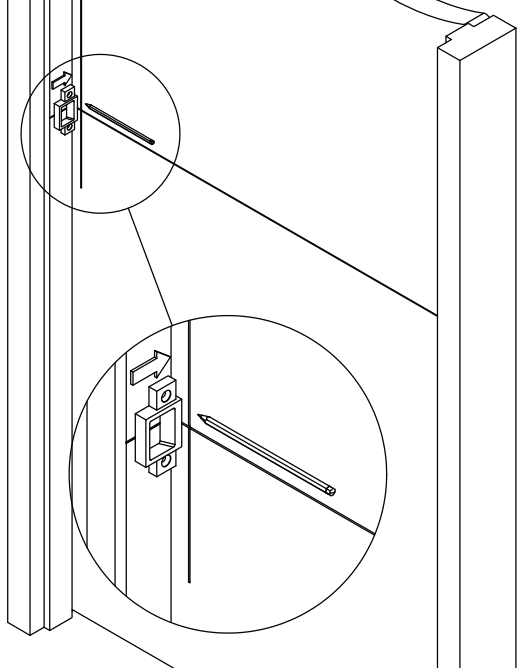

Place strike against frame, centered on the line marked in Step 1. With the strike pressed against the closed door, trace upper and lower strike slots.

**3**

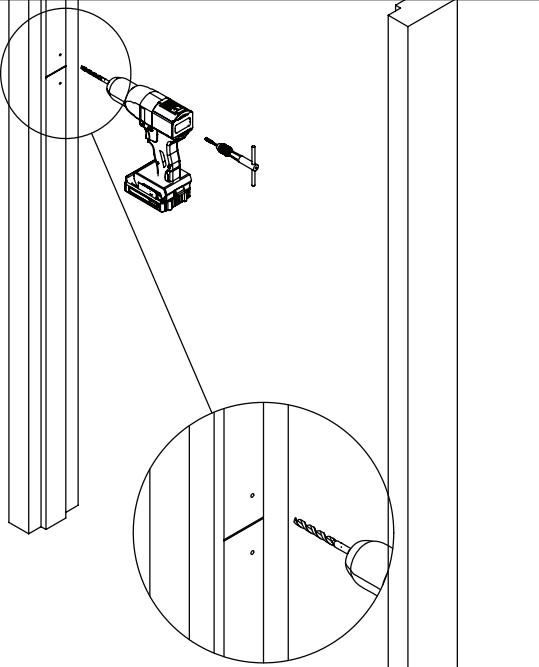

Drill and tap #10-24 holes for strike (2 places).

**4**

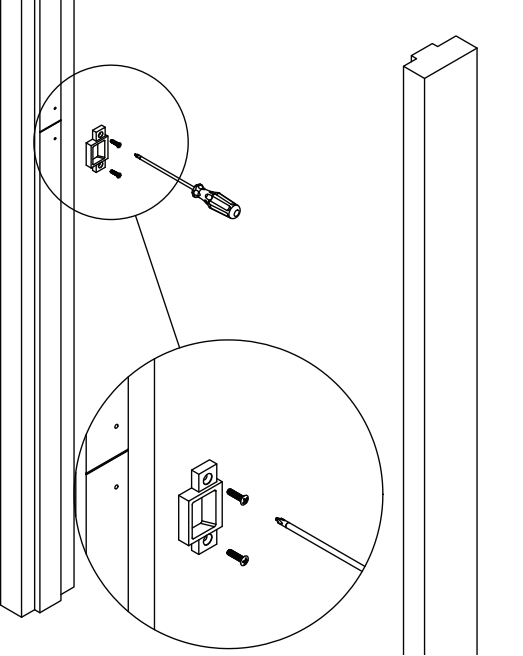

Install strike using oval head phillips #10-24 x 3/4" screws supplied.

# PE8500 Series - Narrow Rim Exit Devices

For Standard, Fire Rated and Aluminium Doors

**SARGENT**

**ASSA ABLOY**

## Installation Instructions

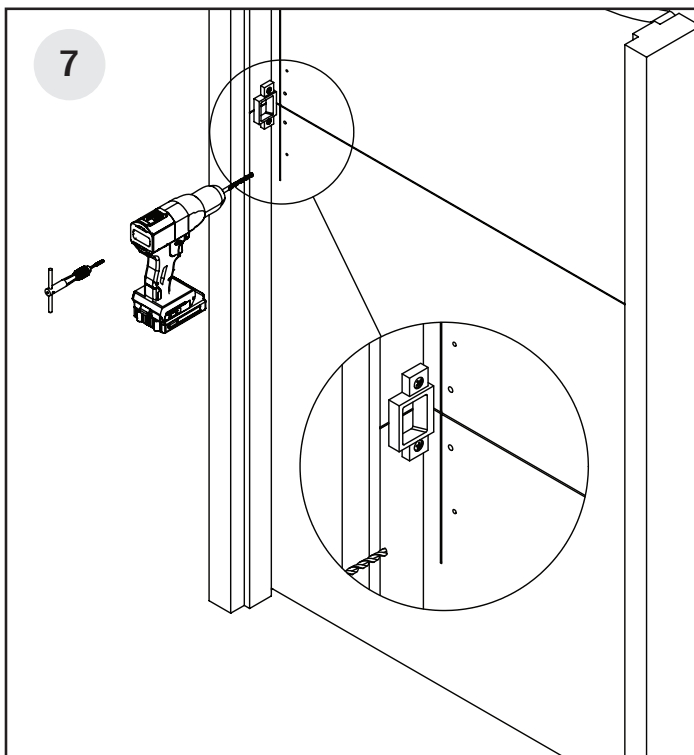
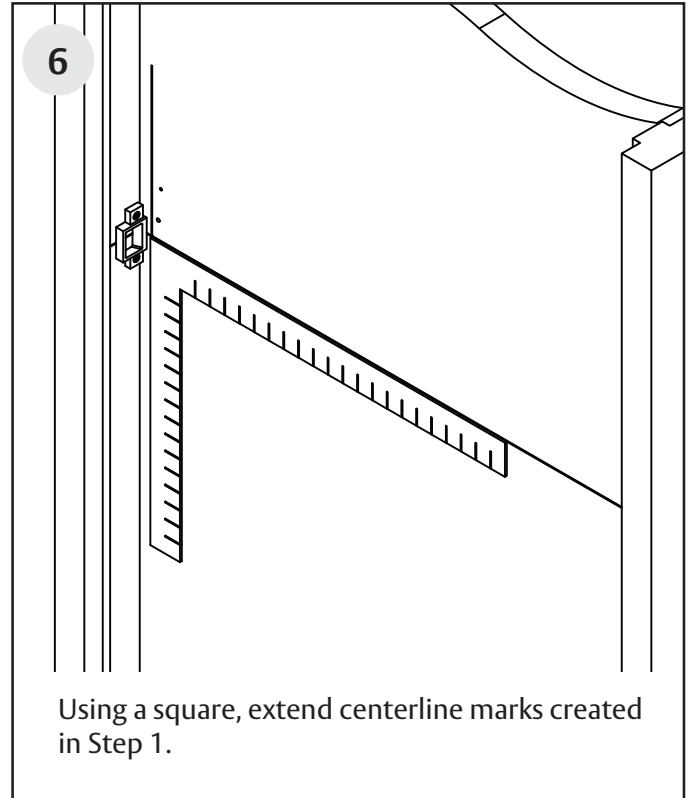
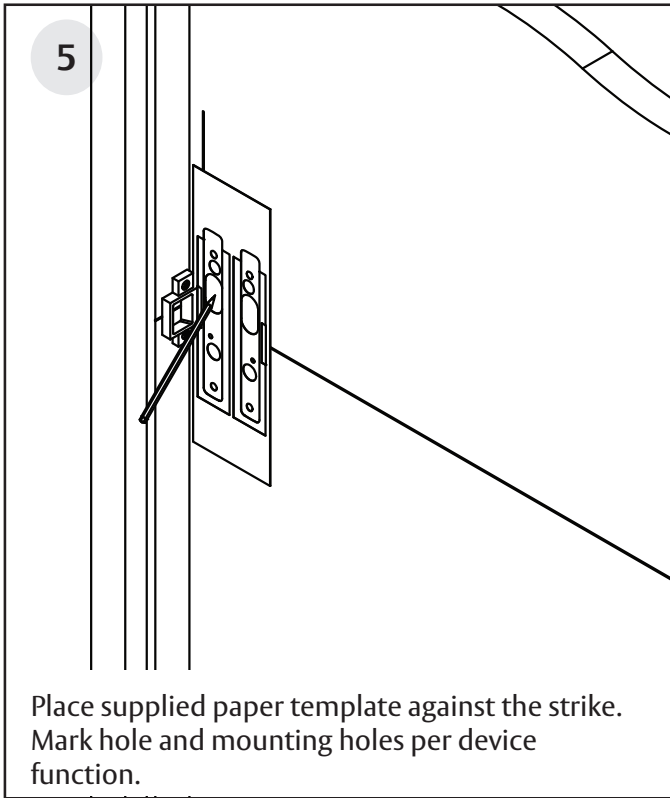

If there is a trim, the chassis is only held on to the door by the trim screws. Use the thru holes. See 7a or 7b.

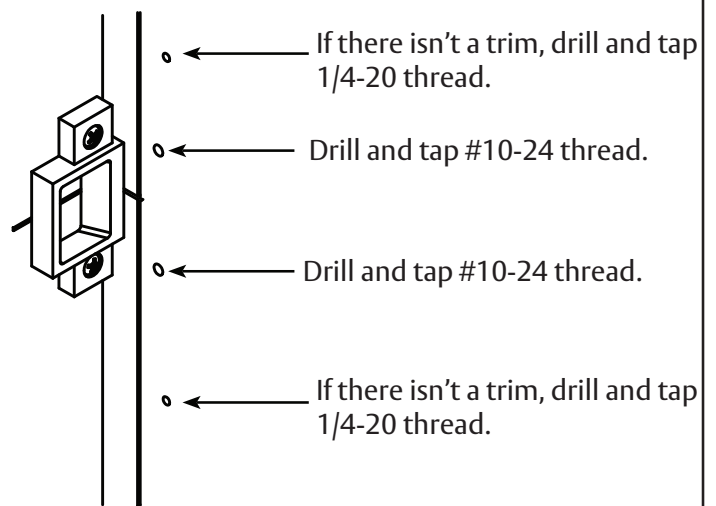

# PE8500 Series - Narrow Rim Exit Devices

For Standard, Fire Rated and Aluminium Doors

**SARGENT**

**ASSA ABLOY**

## Installation Instructions

7a

If you do have a trim: PE8500 / 12-PE8500 - 04, 44, 10, 40 Functions

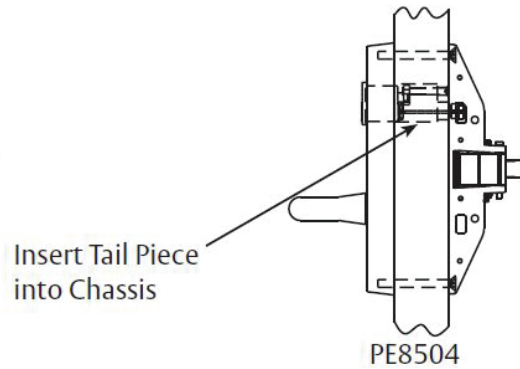
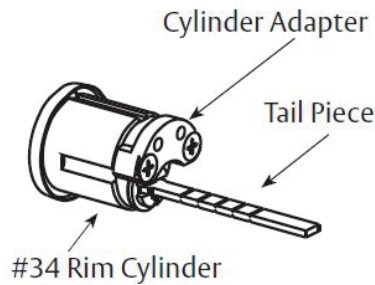

- Thru-bolt chassis to the trim.
- 04/44 functions: Install cylinder adapter on cylinder before installing cylinder in door. Ensure cylinder tail piece fully engages spindle hub. Trim excess tail piece.
- 10/40 Functions: Same except, no cylinder.
- **DO NOT FULLY TIGHTEN SCREWS.**

7b

If you do have a trim: PE8500 / 12-PE8500 13, 15, 43, 73, 74 Functions

Insert Lever Spindle into Chassis

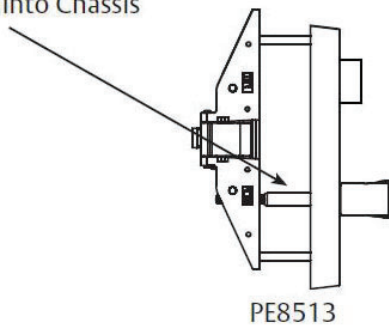

- Thru-bolt chassis to trim.
- Ensure spindle engages chassis.
- **DO NOT FULLY TIGHTEN SCREWS.**

8

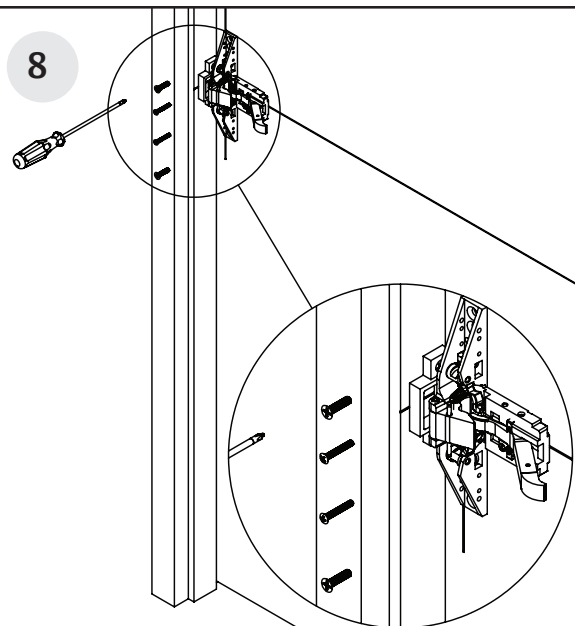

# PE8500 Series - Narrow Rim Exit Devices

For Standard, Fire Rated and Aluminium Doors

**SARGENT**

**ASSA ABLOY**

## Installation Instructions

### Rail cutting guide

If the rail doesn't need to be cut, continue to page 10, step 9.

If the rail must be cut, follow these steps on page 8 and 9:

Refer to the individual exit device installation instructions for rail cutting requirements / restrictions. Instructions will vary based on device type and options.

- Determine cut off dimension "X" by subtracting 2-7/8" from dimension "Y". Mark cut off point on mounting rail. (See below.)

Information for Cutting Rails		
Rail Sizes	Door Widths	
	Standard	Minimum
E	32"	24"
F	36"	33"
J	42"	37"
G	48"	43"

 Do not cut closer than 1-5/8" from the the front edge of the rail insert.

Vertical reference line (Q of chassis)

For doors with stile rail, the stile must overlap by 5/16" min.

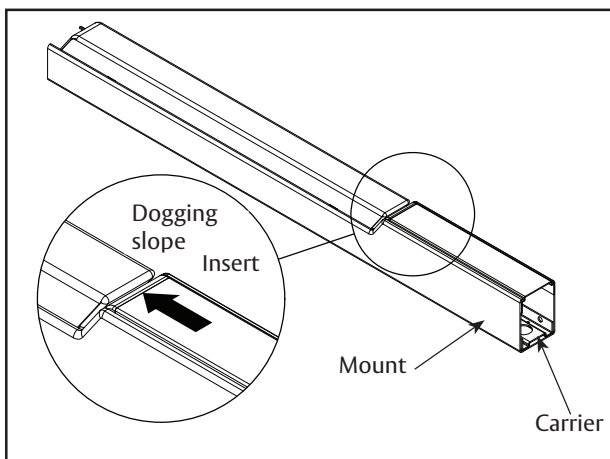
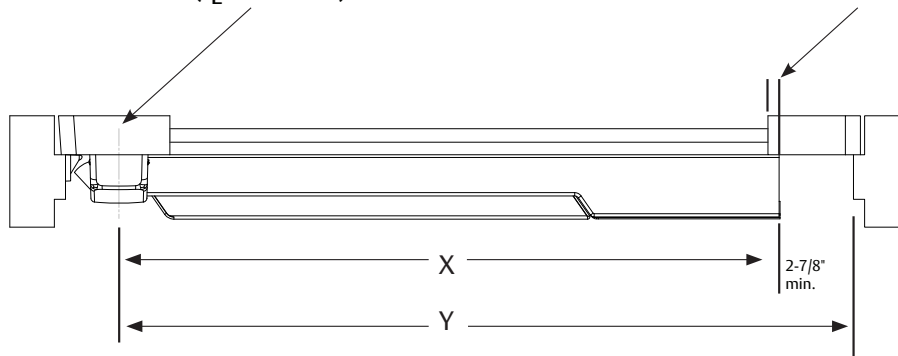

A. Ensure there isn't a gap between the insert and the dogging slope, and the carrier is flush with the mount.

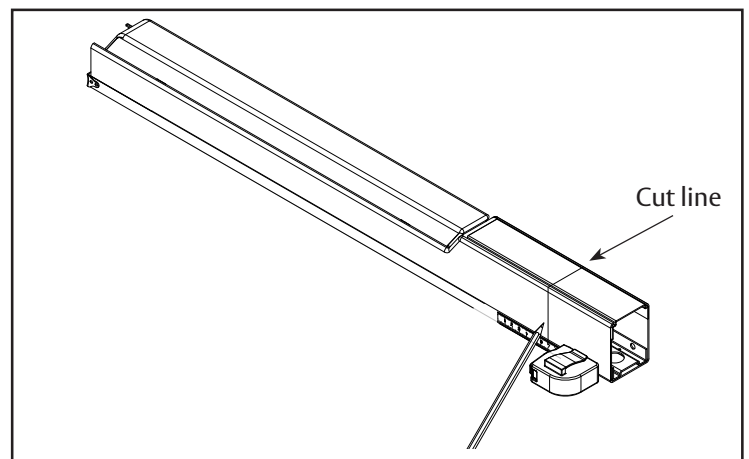

B. Mark rail at the required cut length.



# PE8500 Series - Narrow Rim Exit Devices

For Standard, Fire Rated and Aluminium Doors

**SARGENT**

**ASSA ABLOY**

## Installation Instructions

### Rail cutting guide, continued.

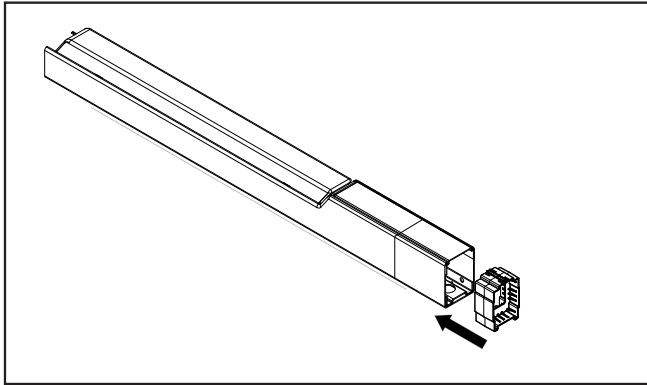

C. Ensure plastic insert support is installed under the cut line.

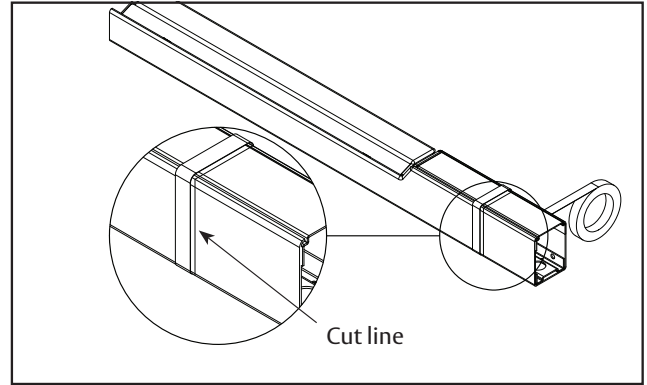

D. Wrap the rail and insert in masking tape, as shown.

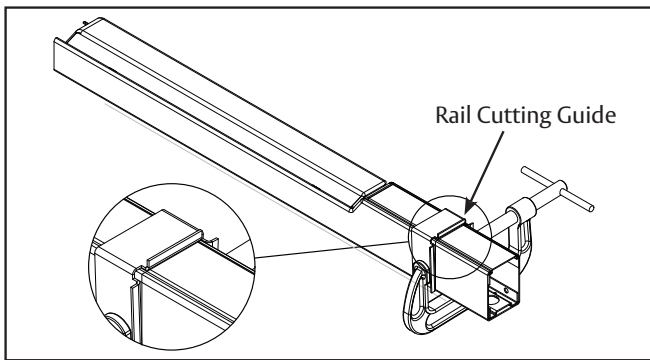

E. Place the rail cutting guide over the masking tape and align it with the cut line. Clamp the cut guide to the rail using a C-clamp.

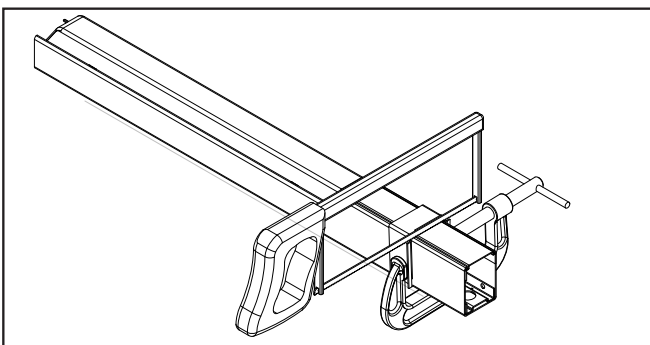

F. Using a hack saw with a new blade or a chop saw with a metal cutting blade, cut the rail, ensuring that the blade stays pressed against the rail cutting guide.

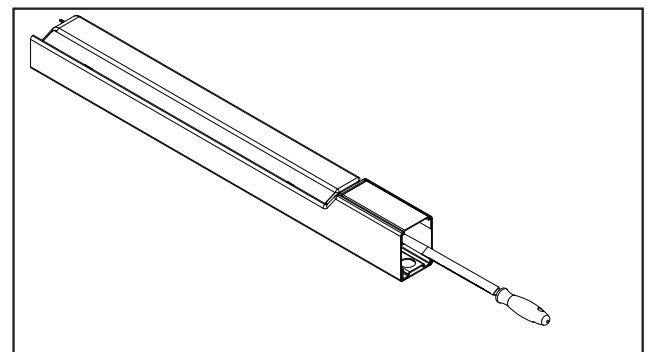

G. Deburr and smooth all cut edges with a file.

# PE8500 Series - Narrow Rim Exit Devices

For Standard, Fire Rated and Aluminium Doors

## Installation Instructions

**SARGENT**

**ASSA ABLOY**

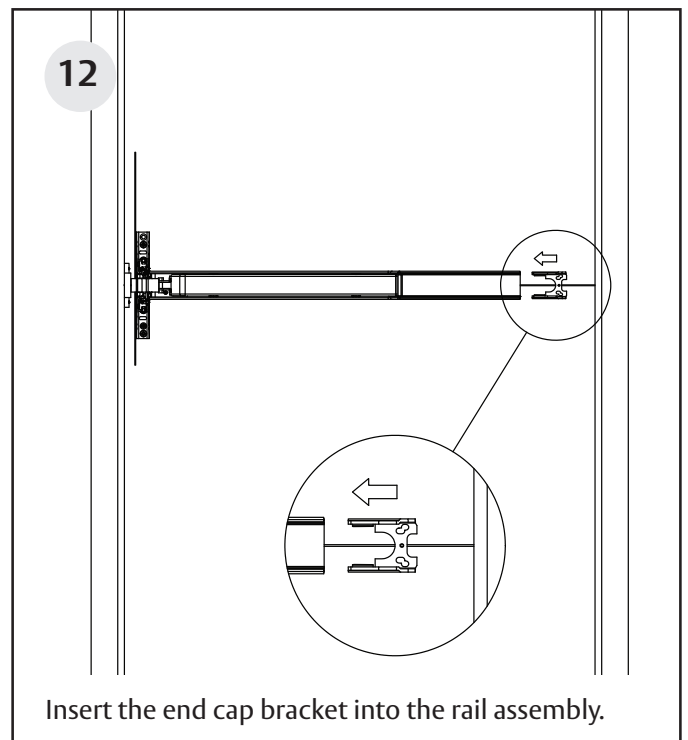
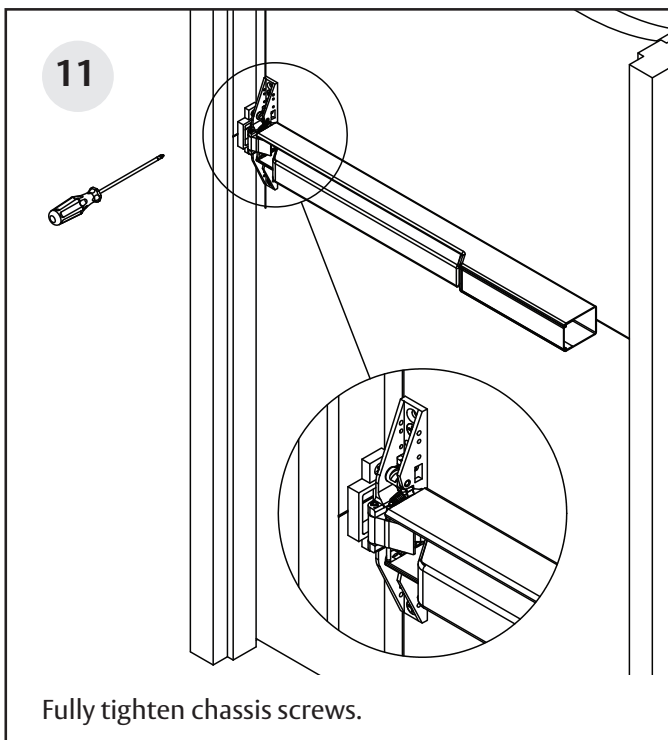
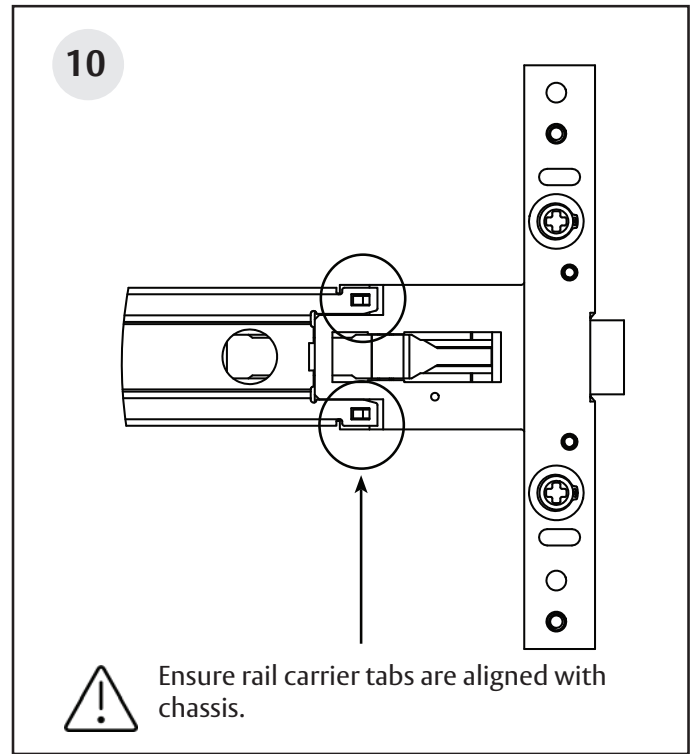
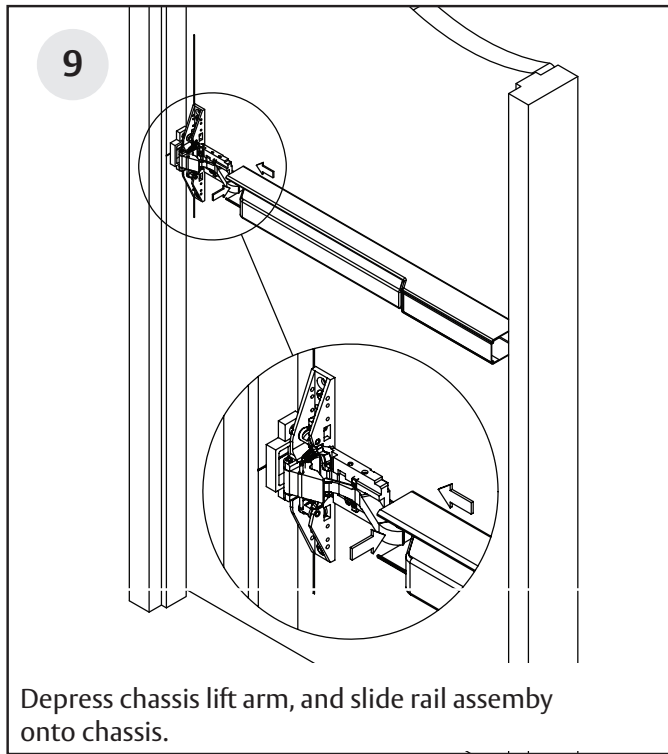

# PE8500 Series - Narrow Rim Exit Devices

For Standard, Fire Rated and Aluminium Doors

**SARGENT**

**ASSA ABLOY**

## Installation Instructions

13

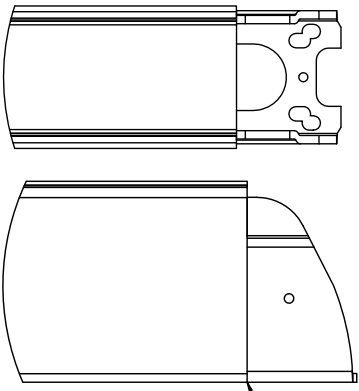

Ensure mounting rail bracket is against the rail without a gap.

14

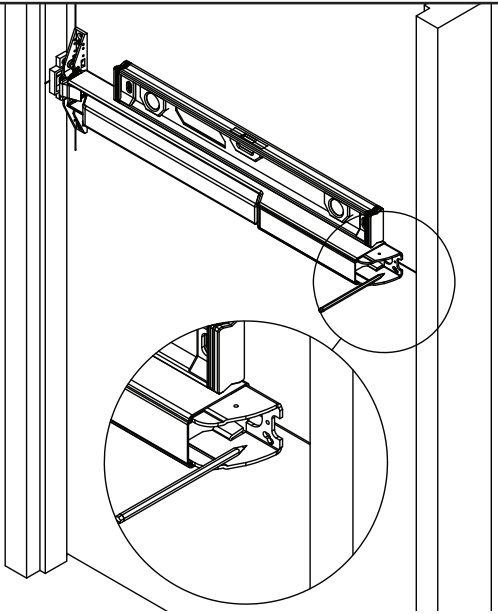

Level the rail and mark mounting holes, using the bracket as a guide.

15

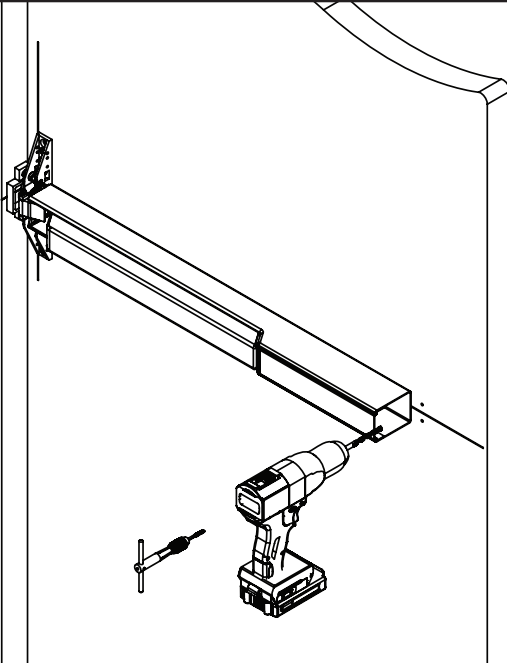

Drill and tap end cap bracket holes #10-24 (2 places)

16

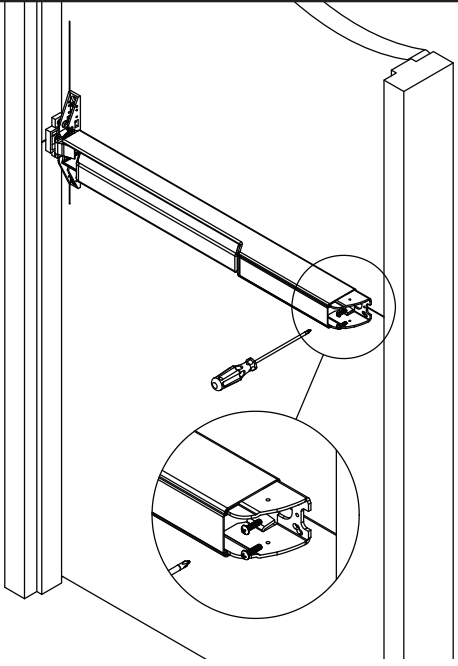

Install end cap bracket using round head Phillips #10-24 x 1" screws, supplied.

17

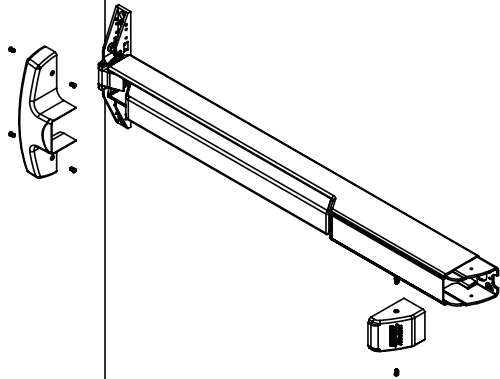

Install chassis and end cap cover using the supplied 8-32 x 5/16" oval head screws.

18

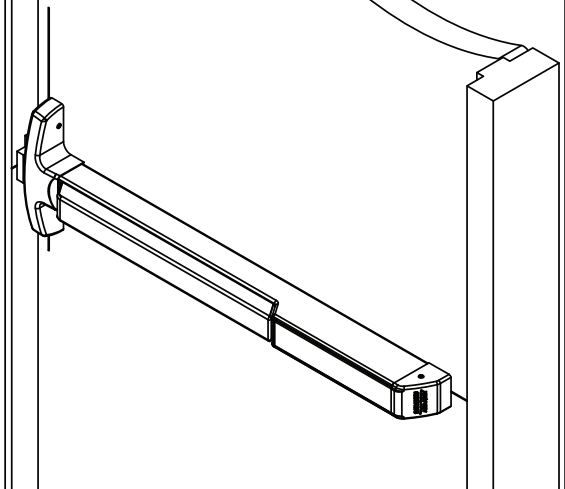

Check for proper operation.

19

(53-) Latch Bolt Monitoring Adjustment

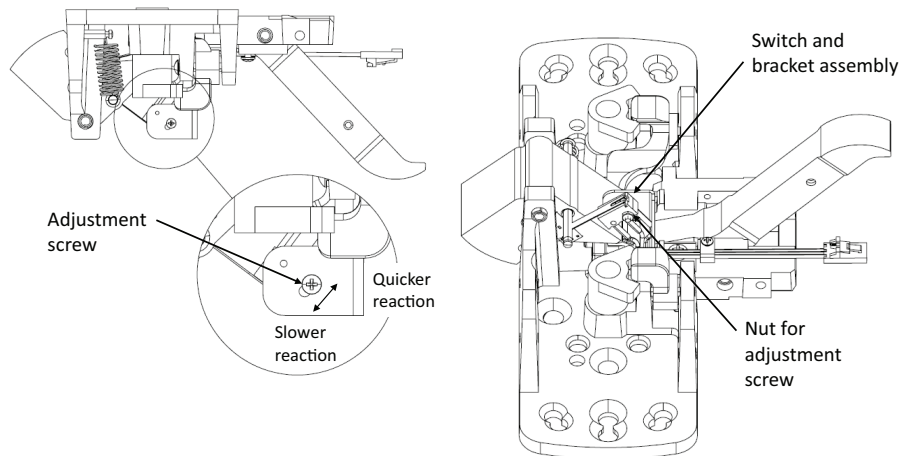

- Loosen adjustment screw and nut.
- Rotate switch.
- Tighten adjustment screw and nut.
- Check operation.

For more information scan the QR code.

