

Installation Instructions

SARGENT
ASSA ABLOY

PE8300 & 12-PE8300 Series

Mortise Lock Type Exit Device

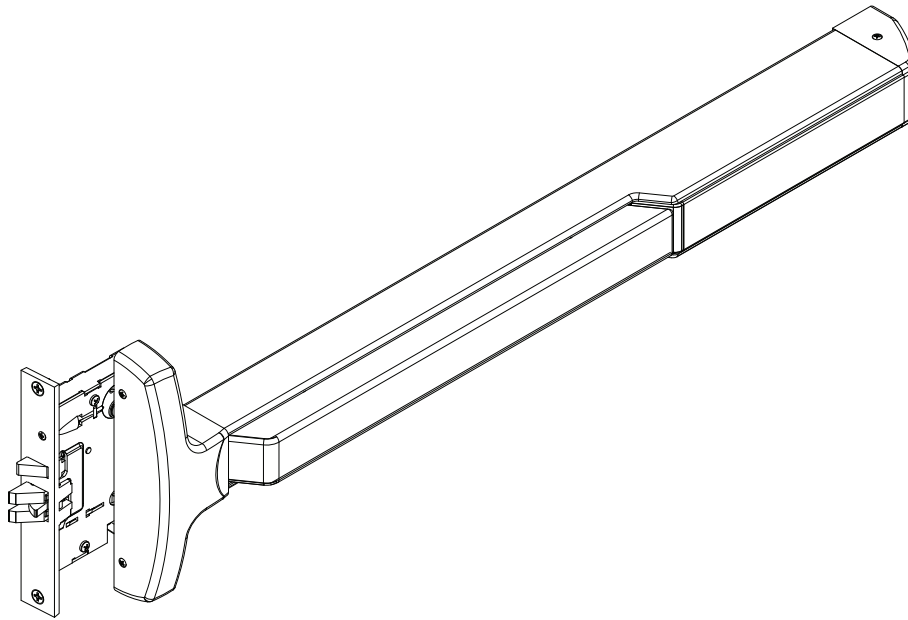

⚠ WARNING

This product can expose you to lead which is known to the state of California to cause cancer and birth defects or other reproductive harm. For more information go to www.P65warnings.ca.gov.

⚠ WARNING

Attention Installer: Improper installation may result in damage to the product and void the factory warranty.

1-800-727-5477 • www.sargentlock.com

Copyright © 2023, SARGENT Manufacturing Company. All rights reserved. Reproduction in whole or in part without the express written permission of SARGENT Manufacturing Company is prohibited. Patent pending and/or patent www.assaabloydss.com/patents.

A8303-1 5/23

Experience a safer
and more open world





PE8300 Series

Mortise Lock Type Exit Device

Installation Instructions

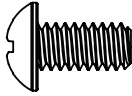
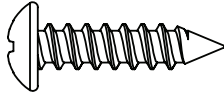
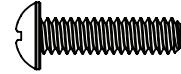
Screw Chart

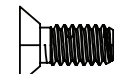
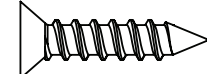

SCREW	TOTAL QTY SUPPLIED	WHERE USED
 1/4" X 1/2" ROUND HEAD MACHINE SCREW	2	(2) CHASSIS (METAL DOOR)
 1/4"-10 X 1" ROUND HEAD WOOD SCREW	2	(2) CHASSIS (WOOD DOOR)
 #10-24 X 3/4" ROUND HEAD MACHINE SCREW	2	(2) REAR MOUNTING PLATE (METAL DOOR)
 #10 X 1-1/4" ROUND HEAD WOOD SCREW	2	(2) REAR MOUNTING PLATE (WOOD DOOR)
 #12-24 X 1/2" FLAT HEAD MACHINE SCREW	4	(2) 908 STRIKE (METAL FRAME) (2) MORTISE LOCK BODY (METAL DOOR)
 #10 X 1" FLAT HEAD WOOD SCREW	4	(2) 908 STRIKE (WOOD FRAME) (2) MORTISE LOCK BODY (WOOD DOOR)
 #8-32 X 5/16" W/ #6 OVAL HEAD MACHINE SCREW	6	(4) CHASSIS COVER (2) END CAP
 1/4"-20 X 2-3/8" KNURLED FLAT HEAD MACHINE SCREW	2	(2) EXIT TRIM (IF USED)

PE8300 Series

SARGENT®

ASSA ABLOY

Mortise Lock Type Exit Device

Installation Instructions

Tools Needed

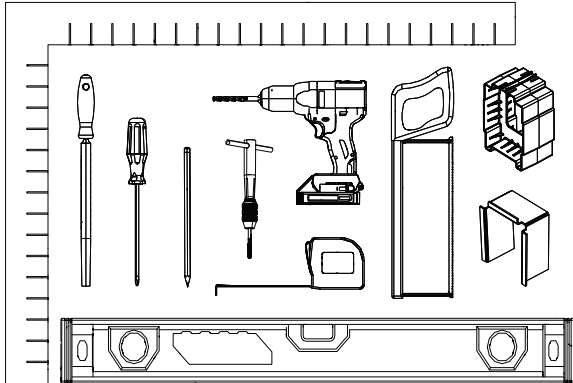

Support Block (Provided)

Rail Cutting Guide (Provided)

PE8300 & 12-PE8300 Exploded View

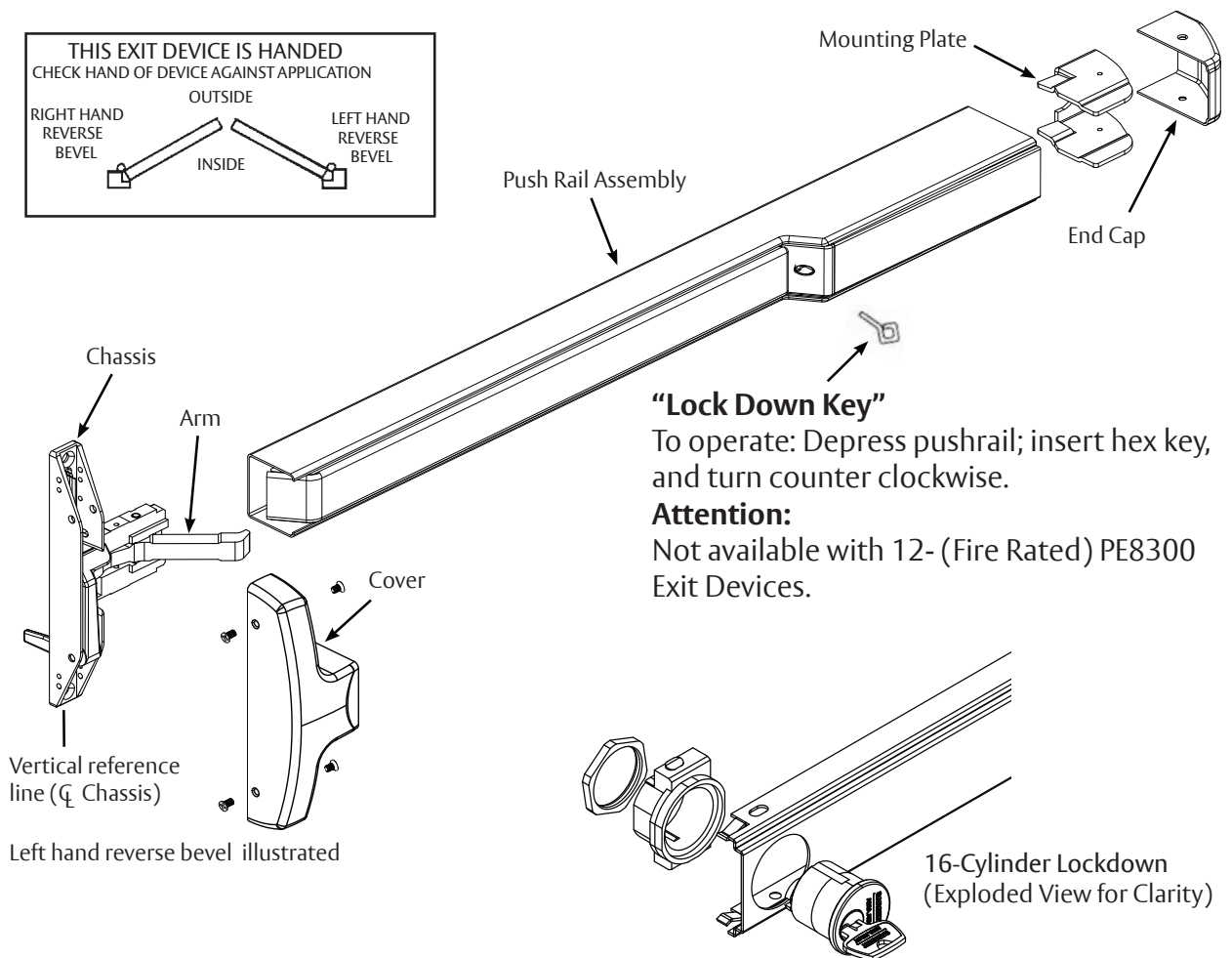
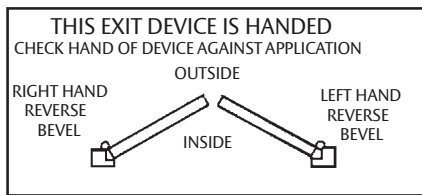

PE8300 Series

Mortise Lock Type Exit Device

SARGENT[®]

ASSA ABLOY

Installation Instructions

Product Overview

Before installation:



1. Check hand of door. This device is handed and non-reversible.
2. Install mullion, if used.
3. Fit and hang door.
4. For wood doors, use wood screws and prep accordingly.



The surface of the door where the exit device is to be applied must be flush. Clear away any raised projections to allow exit device to rest on the flat surface of the door. If shim kit is required, contact your distributor.

Note: Please refer to trim and other installation instructions provided in the box.

PE8300 Series

Mortise Lock Type Exit Device

Installation Instructions

SARGENT[®]

ASSA ABLOY

1

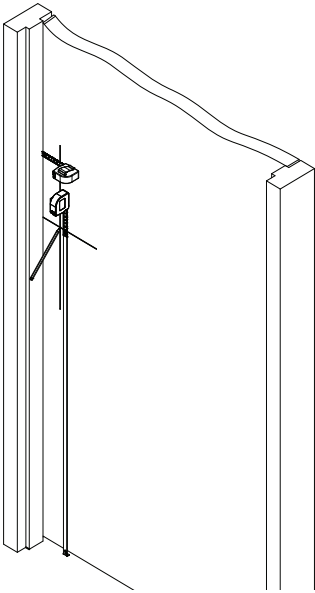

Obtain dimension to finished floor from template or from relationship to strike prep. Mark vertical centerline by measuring 2 3/4" off of the door edge.

2

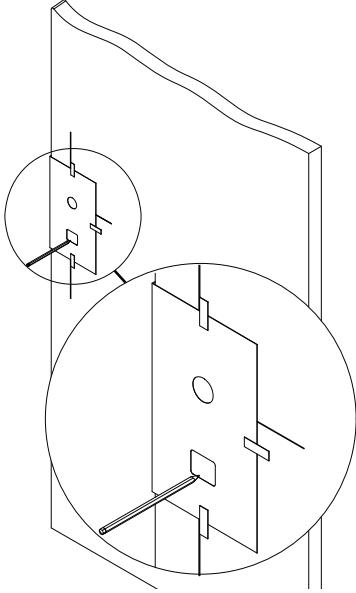

Place template against frame, centered on the line marked in Step 1. Mark and prepare door according to template.

3

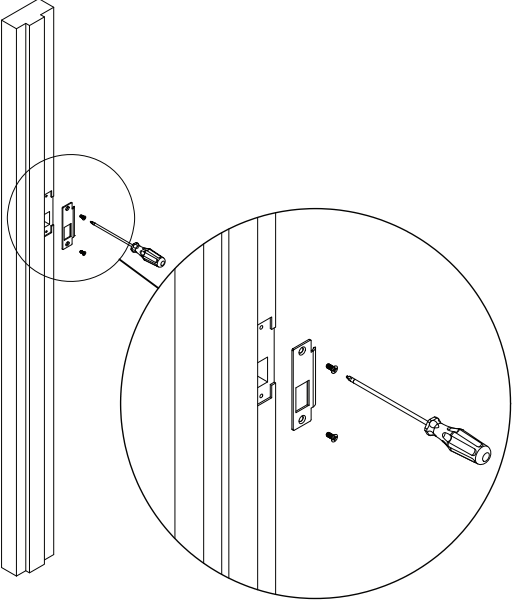

Install the strike to door frame using flat head #12-24 x 1/2" long screws.

4

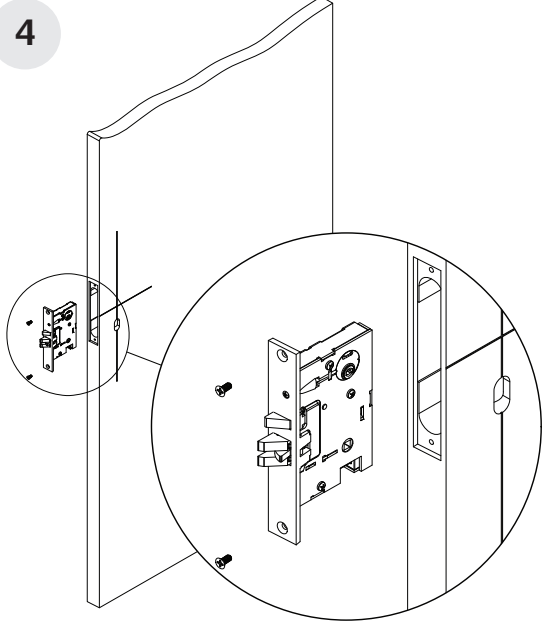

Install the mortise lock body using flat head #12-24 x 1/2" long screws.

PE8300 Series

Mortise Lock Type Exit Device

Installation Instructions

SARGENT

ASSA ABLOY

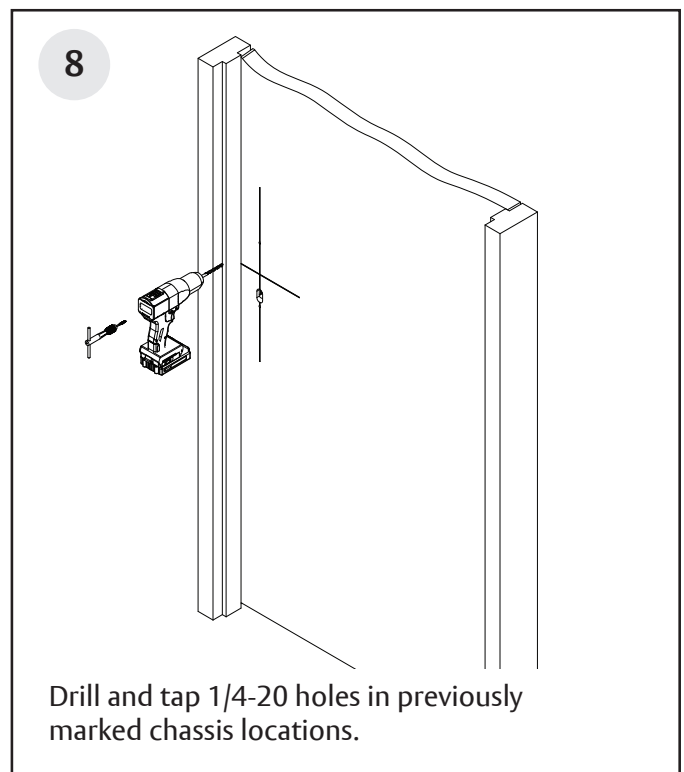
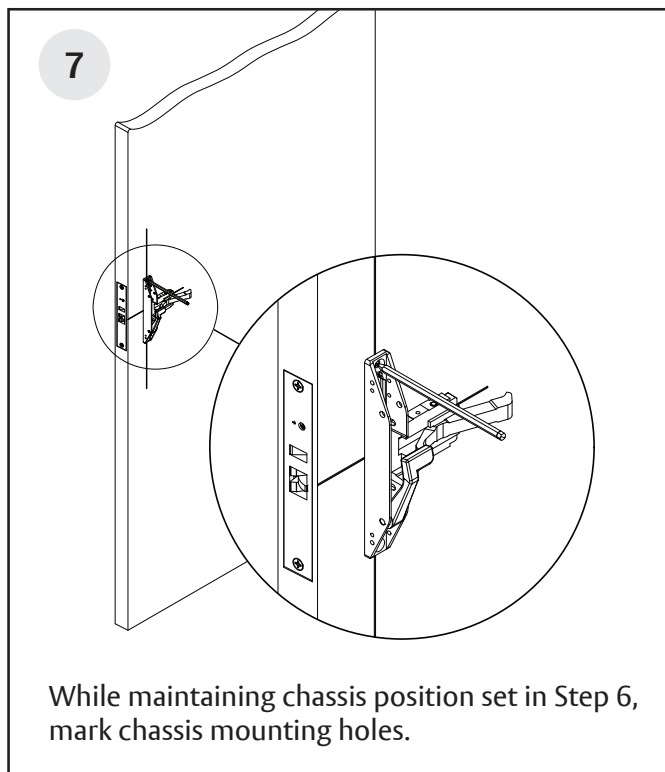
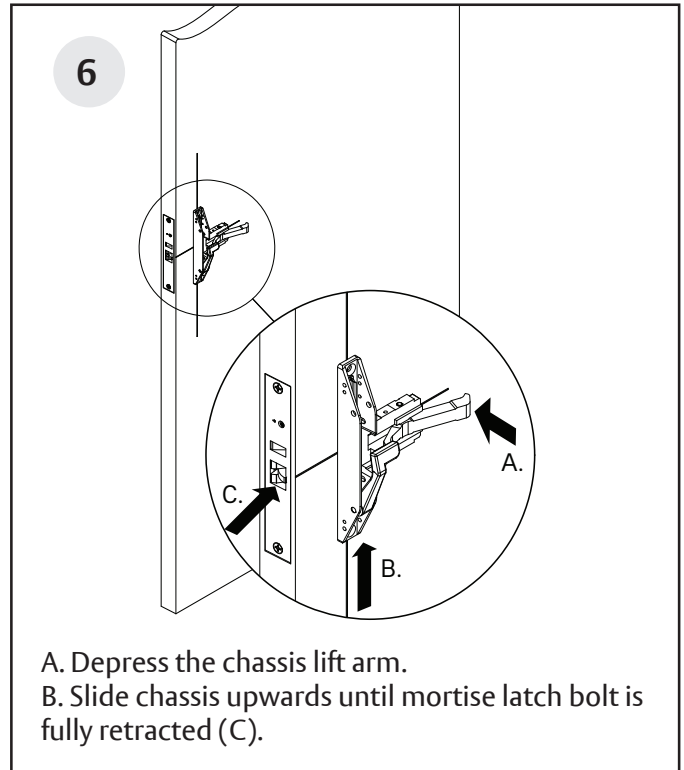
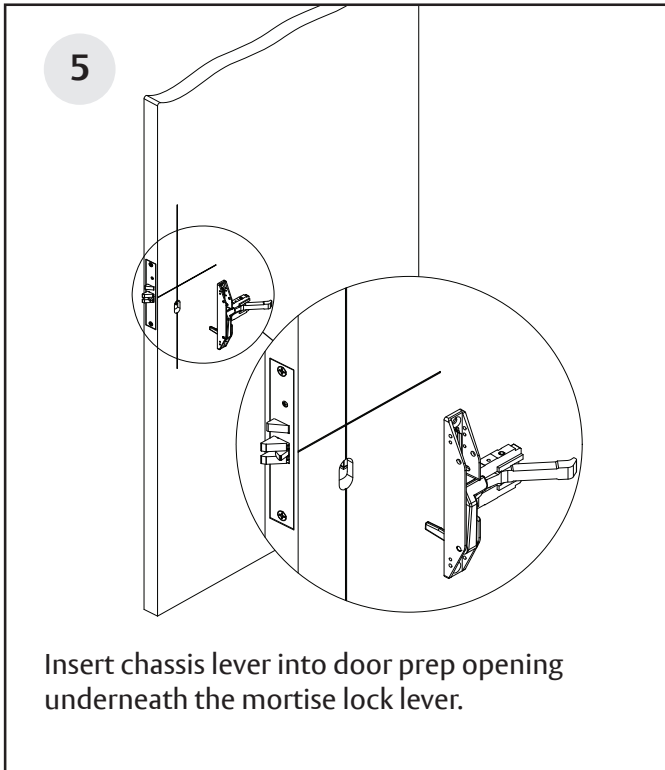

PE8300 Series

Mortise Lock Type Exit Device

Installation Instructions

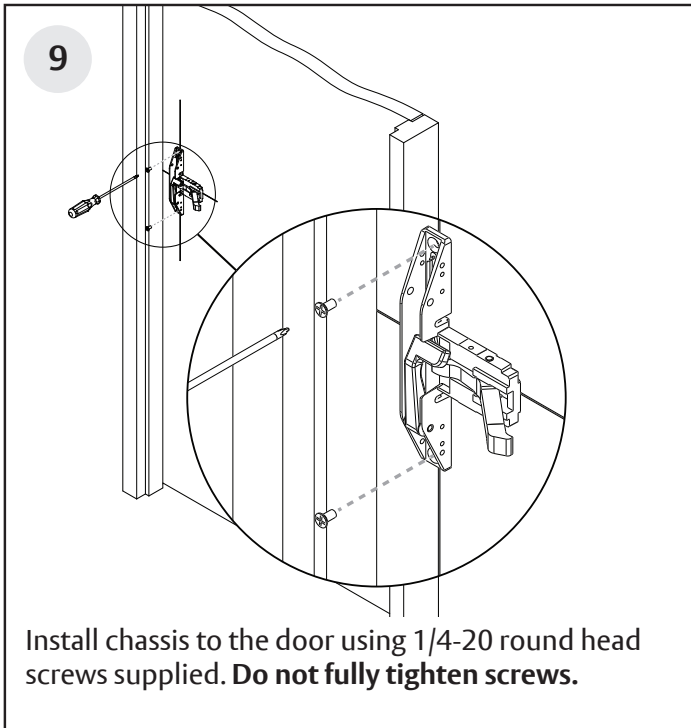

Mortise Lock Type Exit Device

Installation Instructions

Rail cutting guide

If the rail doesn't need to be cut, continue to page 9, step 10.

If the rail must be cut, follow these steps on page 7 and 8:

Refer to the individual exit device installation instructions for rail cutting requirements / restrictions. Instructions will vary based on device type and options.

- Determine cut off dimension "X" by subtracting 2-7/8" from dimension "Y". Mark cut off point on mounting rail. (See below.)

Information for Cutting Rails		
Rail Sizes	Door Widths	
	Standard	Minimum
E	32"	24"
F	36"	33"
J	42"	37"
G	48"	43"

 Do not cut closer than 1-5/8" from the the front edge of the rail insert.

Vertical reference line (C of chassis)

For doors with stile rail, the stile must overlap by 5/16" min.

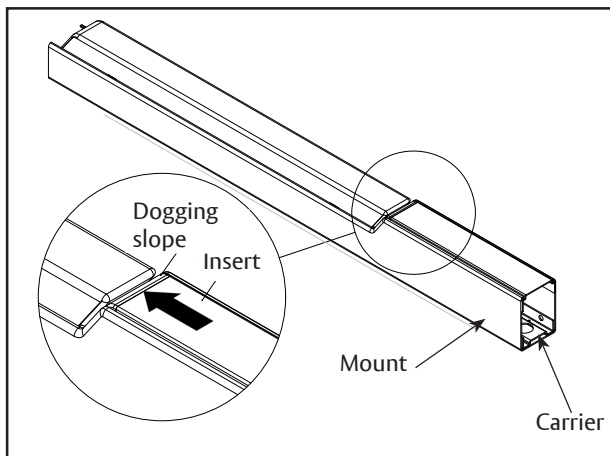
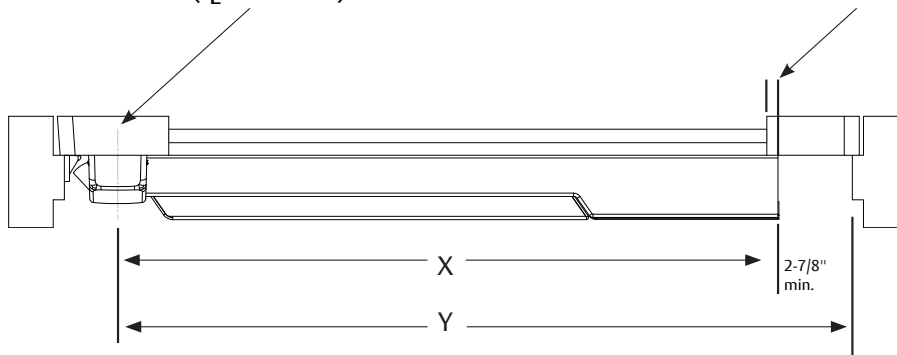

A. Ensure there isn't a gap between the insert and the dogging slope, and the carrier is flush with the mount.

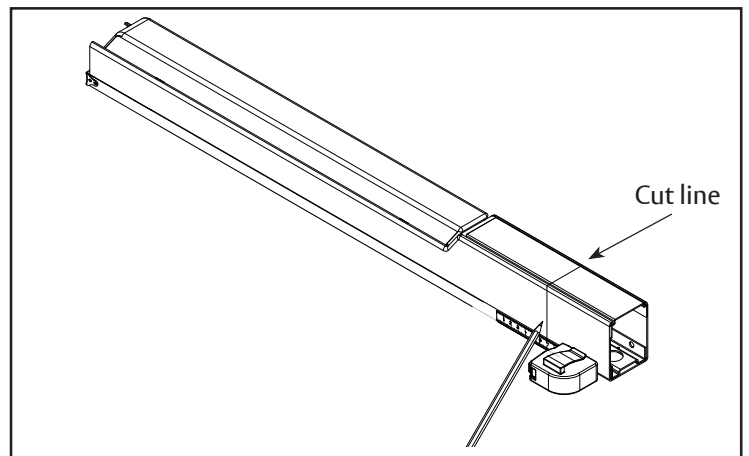

B. Mark rail at the required cut length.

PE8300 Series

Mortise Lock Type Exit Device

Installation Instructions



Rail cutting guide, continued.

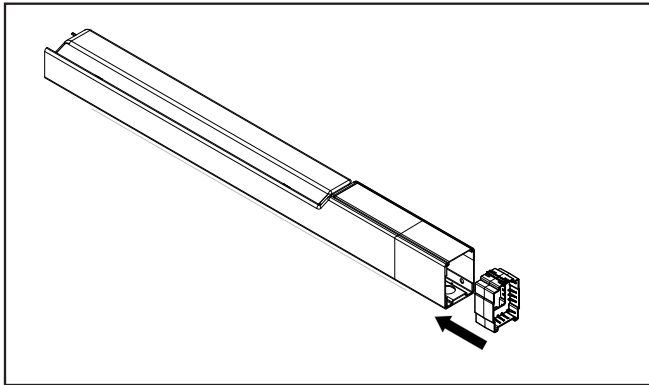

C. Ensure plastic insert support is installed under the cut line.

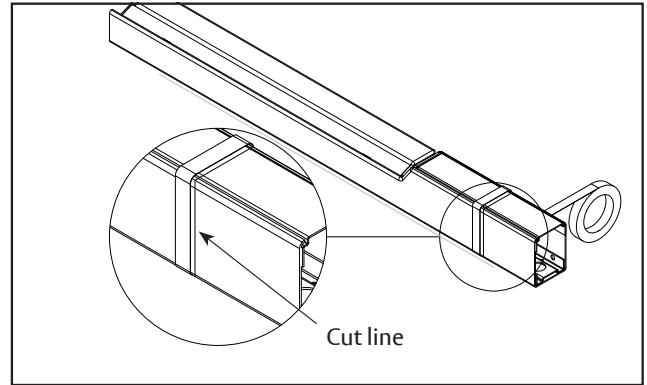

D. Wrap the rail and insert in masking tape, as shown.

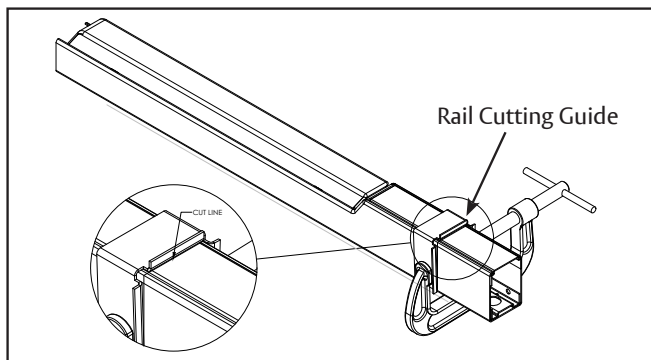

E. Place the rail cutting guide over the masking tape and align it with the cut line. Clamp the cut guide to the rail using a C-clamp.

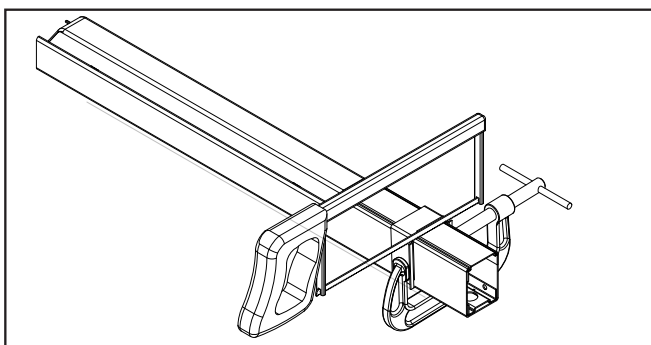

F. Using a hack saw with a new blade or a chop saw with a metal cutting blade, cut the rail, ensuring that the blade stays pressed against the rail cutting guide.

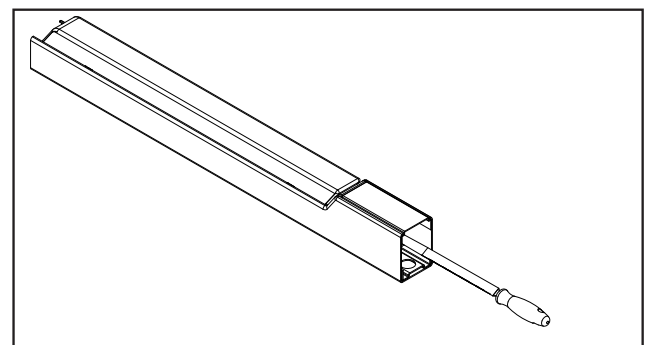

G. Deburr and smooth all cut edges with a file.

PE8300 Series

Mortise Lock Type Exit Device

Installation Instructions

SARGENT

ASSA ABLOY

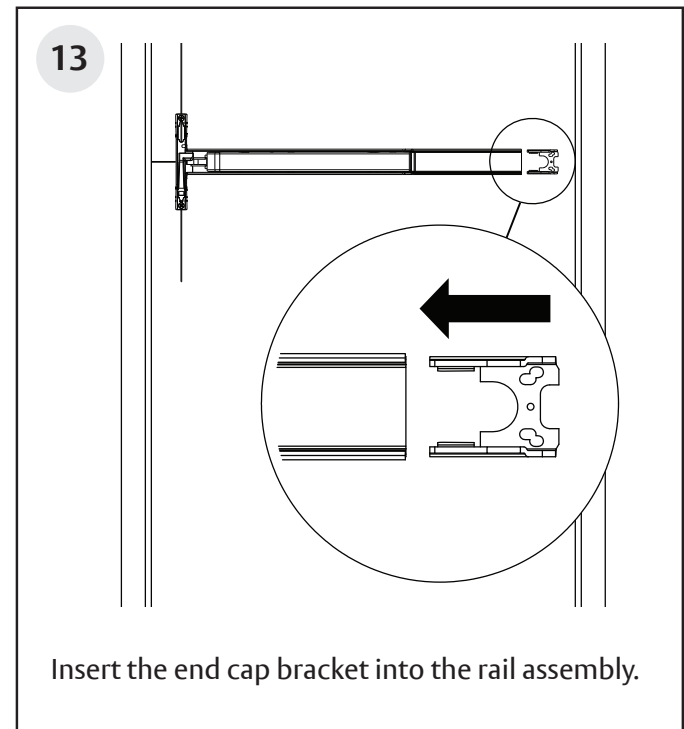
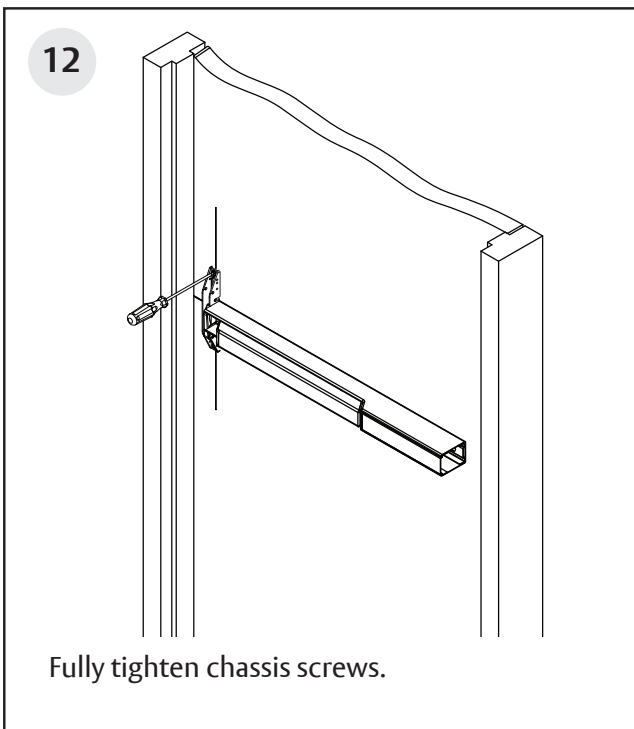
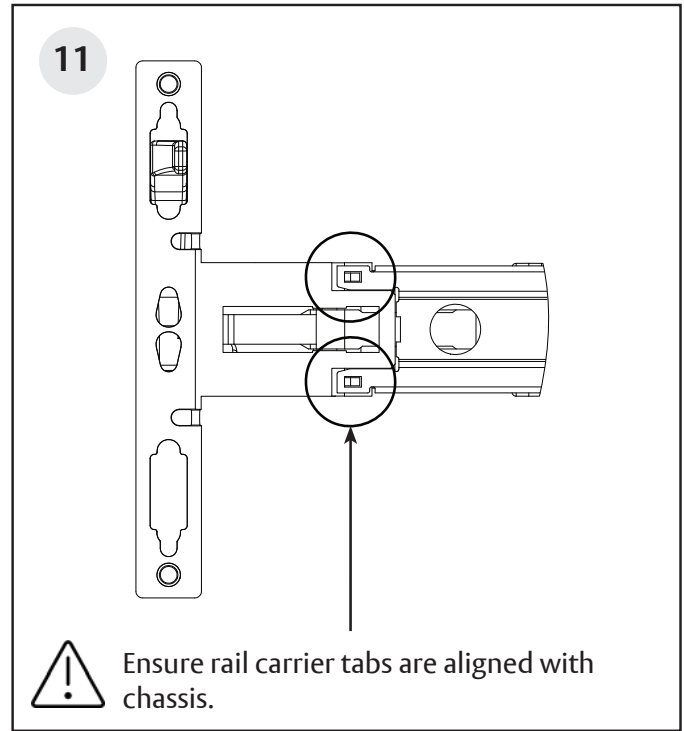
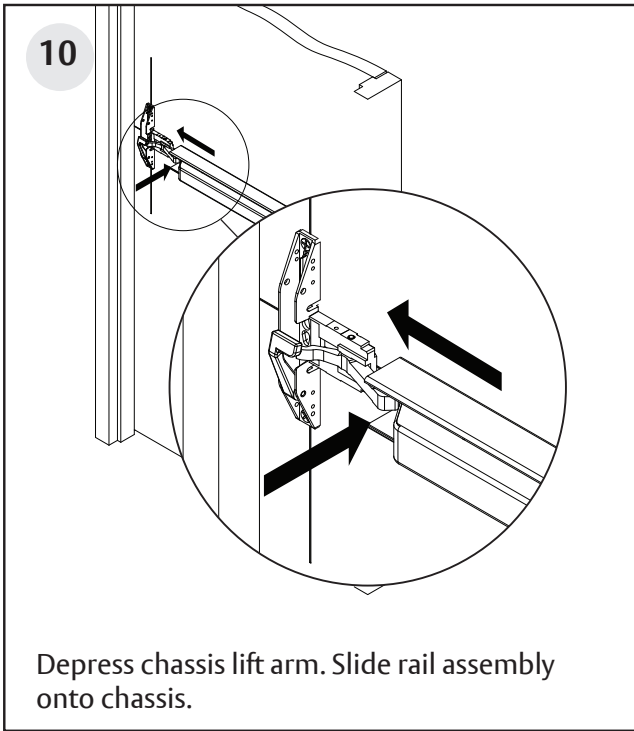

PE8300 Series

Mortise Lock Type Exit Device

Installation Instructions

SARGENT[®]

ASSA ABLOY

