

# Installation Instructions

**SARGENT**  
**ASSA ABLOY**

## PE8600 Series (12-MD, MD, & AD)

### Concealed Vertical Rod Exit Devices

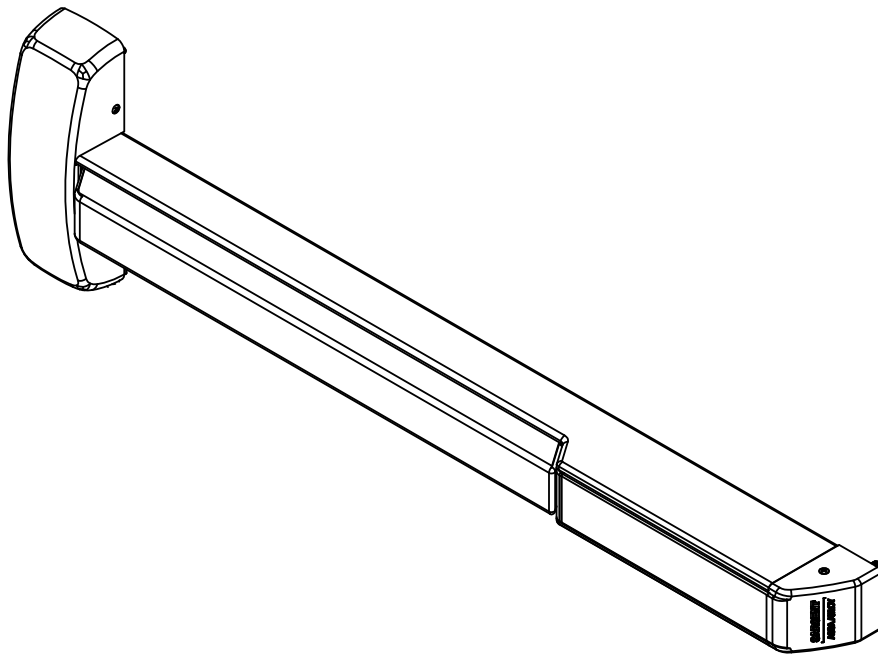

#### **WARNING**

This product can expose you to lead which is known to the state of California to cause cancer and birth defects or other reproductive harm. For more information go to [www.P65warnings.ca.gov](http://www.P65warnings.ca.gov).

#### **WARNING**

Attention Installer: Improper installation may result in damage to the product and void the factory warranty.

1-800-727-5477 • [www.sargentlock.com](http://www.sargentlock.com)

Copyright © 2023, SARGENT Manufacturing Company. All rights reserved. Reproduction in whole or in part without the express written permission of SARGENT Manufacturing Company is prohibited. Patent pending and/or patent [www.assaabloyds.com/patents](http://www.assaabloyds.com/patents).

A8305-1 5/23

Experience a safer  
and more open world

# PE8600 Series (12-MD, MD, & AD)













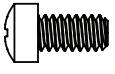

**SARGENT**

**ASSA ABLOY**

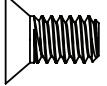
## Concealed Vertical Rod Exit Devices

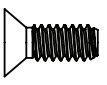
### Installation Instructions

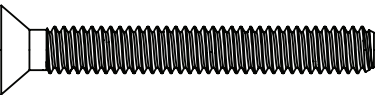
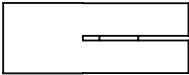
#### Screw Chart

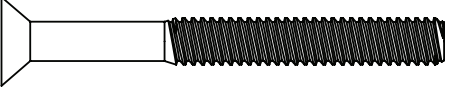
SCREW	TOTAL QTY SUPPLIED	WHERE USED
  # 10-24 X 3/4" FLAT HEAD MACHINE SCREW	4	(4) CHASSIS CORNER MOUNTING HOLES
  # 10-24 X 3/4" ROUND HEAD MACHINE SCREW	2	(2) REAR MOUNTING PLATE
  # 10-24 X 3/8" FILLISTER HEAD MACHINE SCREW	1	(1) INNER CHASSIS TOP MOUNTING HOLE
  # 10-24 X 3/8" OVAL HEAD MACHINE SCREW	4	(2) TOP CASE (2) BOTTOM PLATE (IF AD)
  1/4"-20 X 1/2" FLAT HEAD MACHINE SCREW	2	(2) BOTTOM PLATE (MD OR FIRE RATED)
  # 10-24 X 1/2" U' CUT FLAT HEAD MACHINE SCREW	5	(1) INNER CHASSIS BOTTOM MOUNTING HOLE (2) 640 OR 650 STRIKE, TOP (METAL FRAME) (2) 640 OR 650 STRIKE, BOTTOM (METAL FRAME)
 # 10 X 1-1/4" FLAT HEAD WOOD SCREW	2	(2) 650 STRIKE, TOP (WOOD FRAME) (2) 650 STRIKE, BOTTOM (WOOD FRAME)
  1/4"-20 X 2" FLAT HEAD MACHINE SCREW W/ANCHOR	2	(2) 606 BOTTOM STRIKE (FIRE RATED)
 # 8-32 X 5/16" W/ #6 OVAL HEAD MACHINE SCREW	6	(4) CHASSIS COVER (2) END CAP
 1/4"-20 X 2-3/8" KNURLED FLAT HEAD	2	(2) EXIT TRIM (IF USED)

# PE8600 Series (12-MD, MD, & AD)

**SARGENT**

**ASSA ABLOY**

## Concealed Vertical Rod Exit Devices

### Installation Instructions

### Equipment Needed

#### Tools

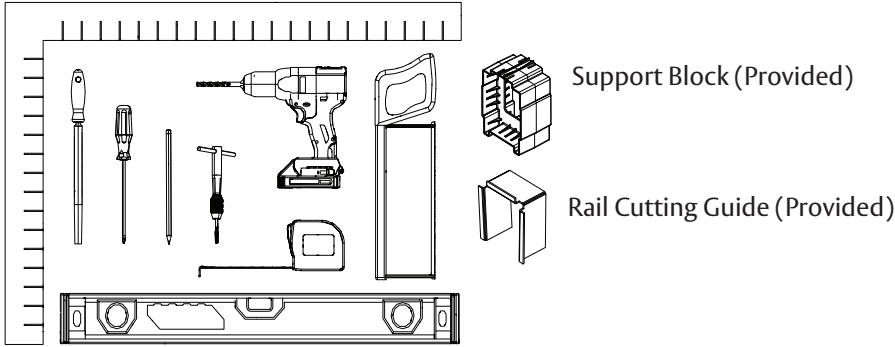

#### Strike Packs

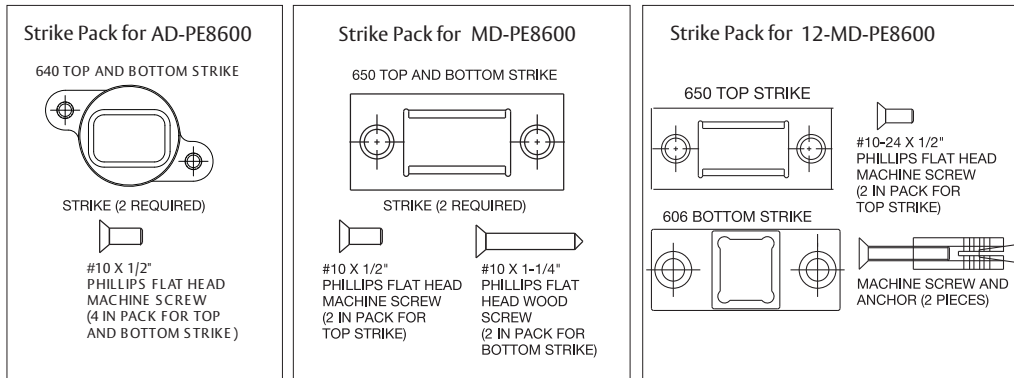

#### Before installation:

1. Fit and hang door.
2. Check the box's label for the size of the exit device.



The surface of the door where the exit device is to be applied must be flush. Clear away any raised projections to allow exit device to rest on the flat surface of the door. If shim kit is required, contact your distributor.

Note: Please refer to trim and other installation instructions provided in the box.

# PE8600 Series (12-MD, MD, & AD)

**SARGENT**

**ASSA ABLOY**

## Concealed Vertical Rod Exit Devices

### Installation Instructions

### Template AD-PE8600, NB-AD-PE8600 & NB-MD-PE8600, MD-PE8600, 12-MD-PE8600

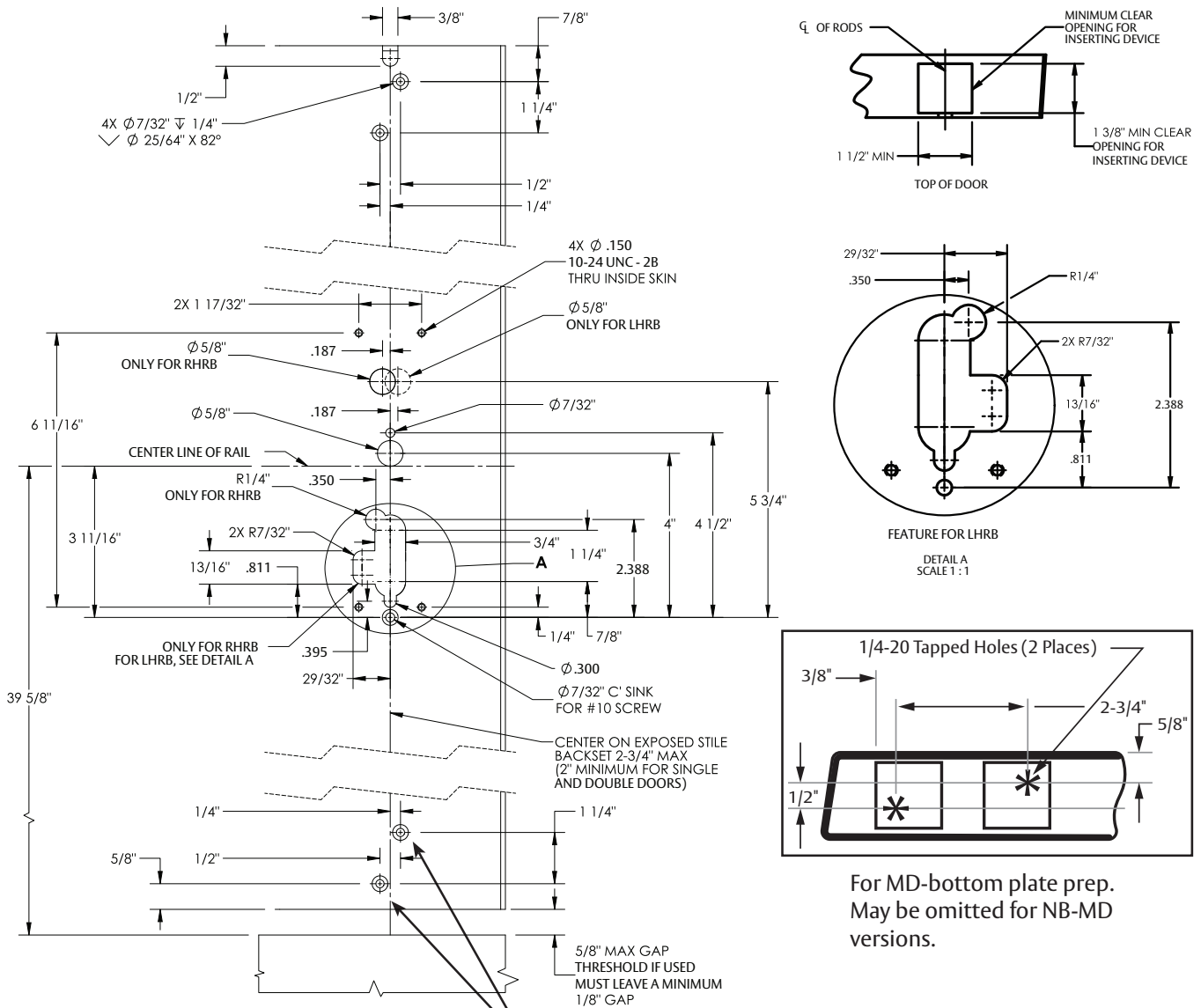

**NOTES:**

1. DOOR PREPARATION SHOWN FOR INSIDE DOOR ONLY.
2. IF OUTSIDE PULL AND/OR OUTSIDE CONTROL IS USED, SEE APPROPRIATE DOOR TEMPLATE FOR OUTSIDE DOOR PREP.
3. \*MIN BACKSET FOR SINGLE DOOR IS BASED ON 1/2" FRAME STOP. LARGER FRAME STOPS REQUIRE LARGER BACKSET.
4. SURFACE OF DOOR WHERE EXIT DEVICE IS TO BE APPLIED, MUST BE FLUSH.
5. WE RECOMMEND THAT ALL TAPPED HOLES BE DRILLED AND TAPPED IN FIELD.
6. TOLERANCE ALL FRACTIONAL DIMENSIONS ± 1/64".
7. BOTTOM AND TOP STRIKES MUST BE USED, SEE STRIKE TEMPLATE NO. MEDT6.
8. SEE TEMPLATE NO. MEDT7 FOR AUX CONTROL IF REQ'D.
9. FOR DEVICES WITH NO BOTTOM ROD, HOLES FOR BOTTOM CASE ARE NOT REQUIRED.

Omit holes for NB- AD version and all MD- versions.

For MD-bottom plate prep.  
May be omitted for NB-MD versions.

# PE8600 Series (12-MD, MD, & AD)

# SARGENT

# ASSA ABLOY

## Concealed Vertical Rod Exit Devices

### Installation Instructions

### Exploded View

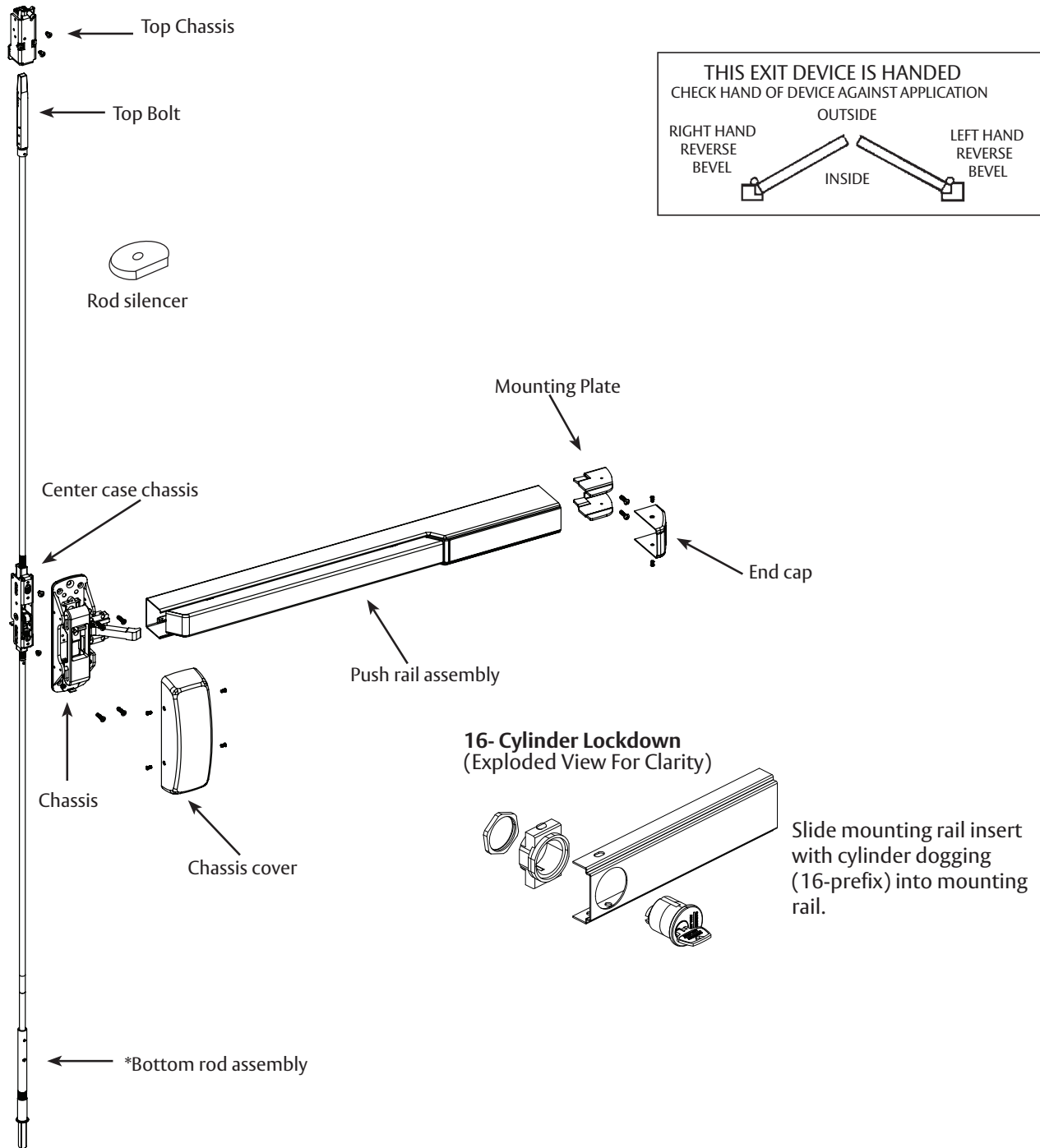

\*Note: The NB-AD-PE8600, NB-MD-PE8600 & the 12-NB-MD-PE8600 do not have a bottom rod assembly.

1-800-727-5477 • [www.sargentlock.com](http://www.sargentlock.com)

Copyright © 2023, SARGENT Manufacturing Company. All rights reserved. Reproduction in whole or in part without the express written permission of SARGENT Manufacturing Company is prohibited. Patent pending and/or patent [www.assaabloydss.com/patents](http://www.assaabloydss.com/patents).

A8305-1 5/23

# PE8600 Series (12-MD, MD, & AD)

## Concealed Vertical Rod Exit Devices

### Installation Instructions

**SARGENT**

**ASSA ABLOY**

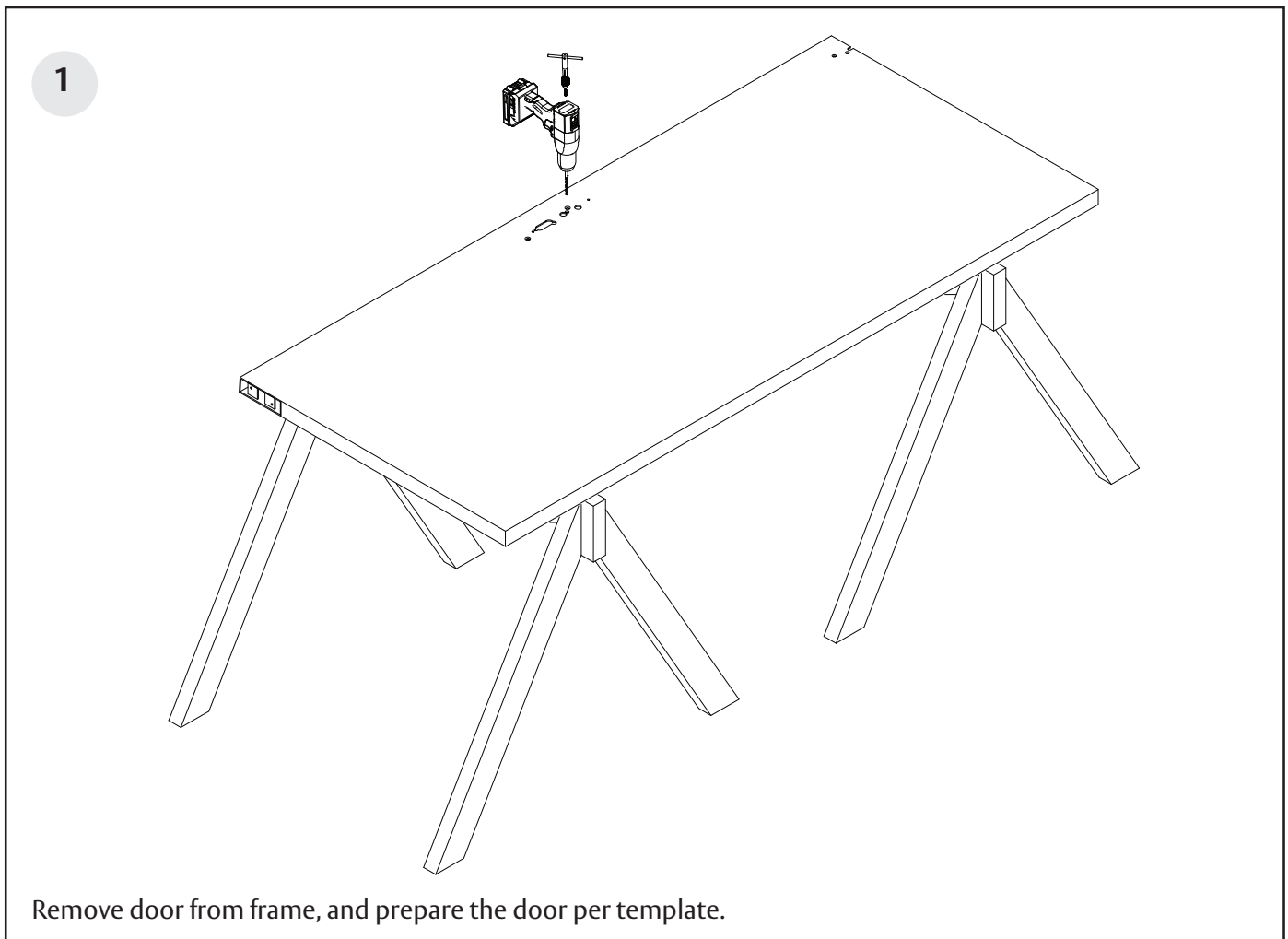

# PE8600 Series (12-MD, MD, & AD)

**SARGENT**

## Concealed Vertical Rod Exit Devices

**ASSA ABLOY**

### Installation Instructions

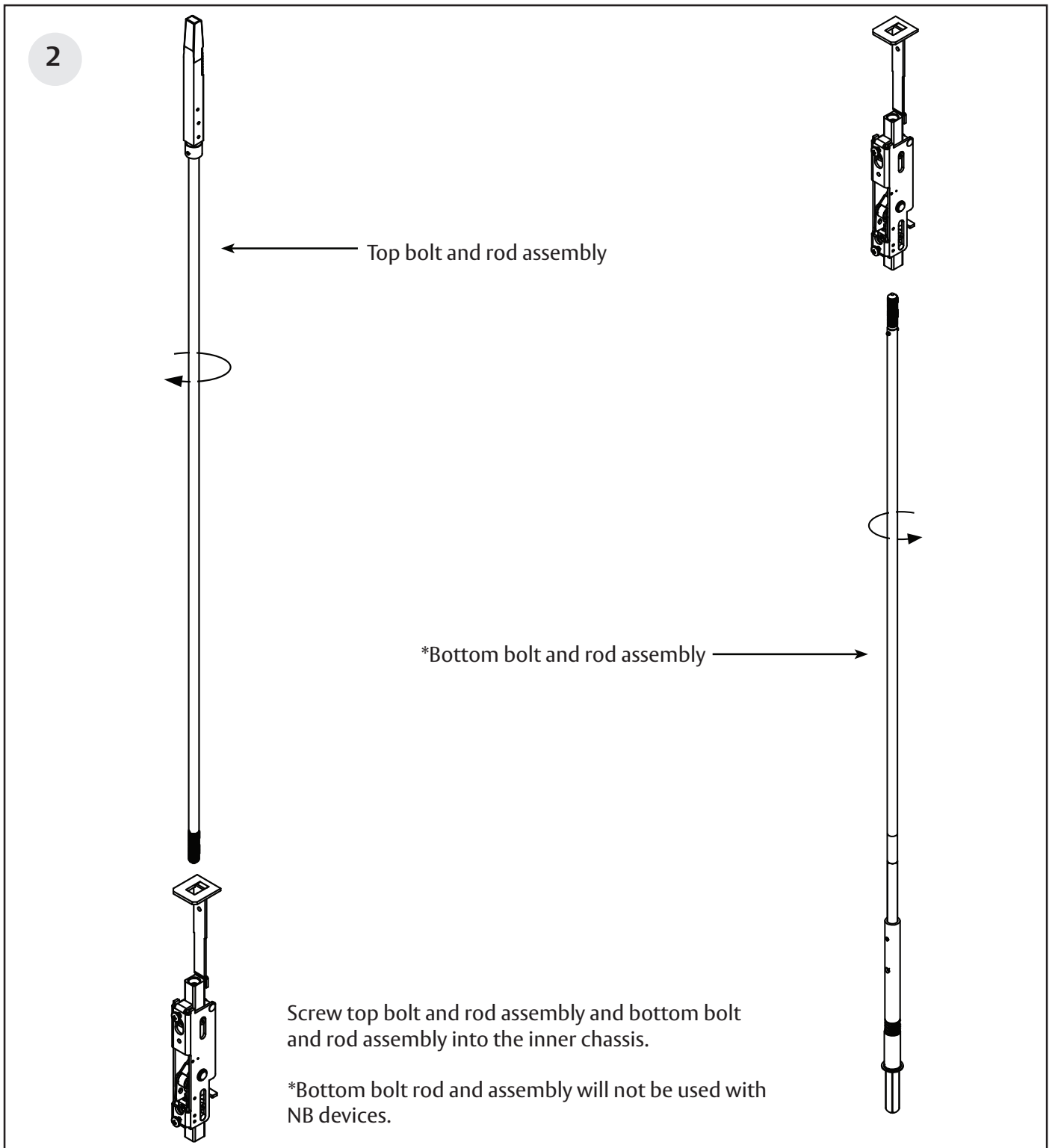

# PE8600 Series (12-MD, MD, & AD)

## Concealed Vertical Rod Exit Devices

### Installation Instructions

**SARGENT**

**ASSA ABLOY**

3

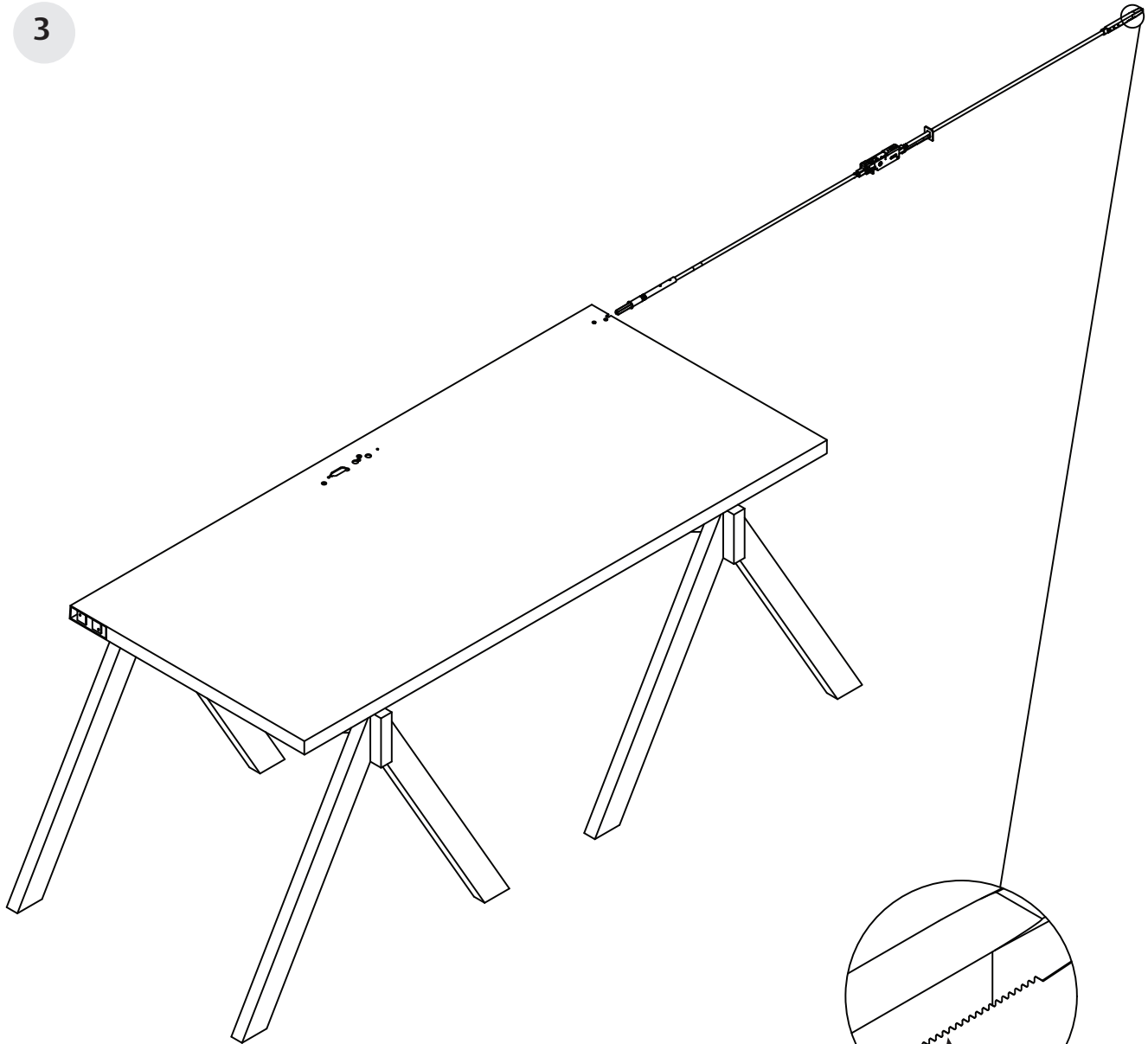

Feed rod and inner chassis assembly into the door. Ensure teeth face down and top bolt teeth are opposite the inside door prep.



# PE8600 Series (12-MD, MD, & AD)

# SARGENT®

# ASSA ABLOY

## Concealed Vertical Rod Exit Devices

### Installation Instructions

**4**

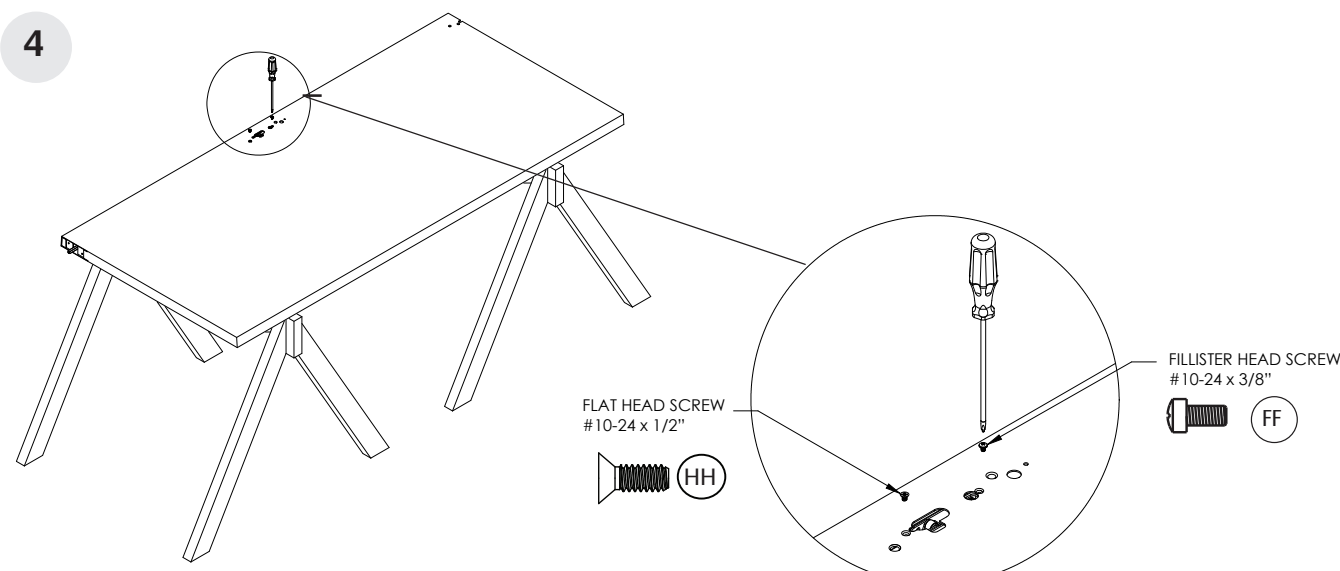

FLAT HEAD SCREW  
#10-24 x 1/2" (HH)

FILLISTER HEAD SCREW  
#10-24 x 3/8" (FF)

Attach inner case chassis to the door with (1) #10-24 x 1/2" flat head screw (HH) and secure with (1) #10-24 x 3/8" fillister head machine screw (FF). If P700 series trim is being used, it must be installed at this point. See P700 instructions for details.

**5**

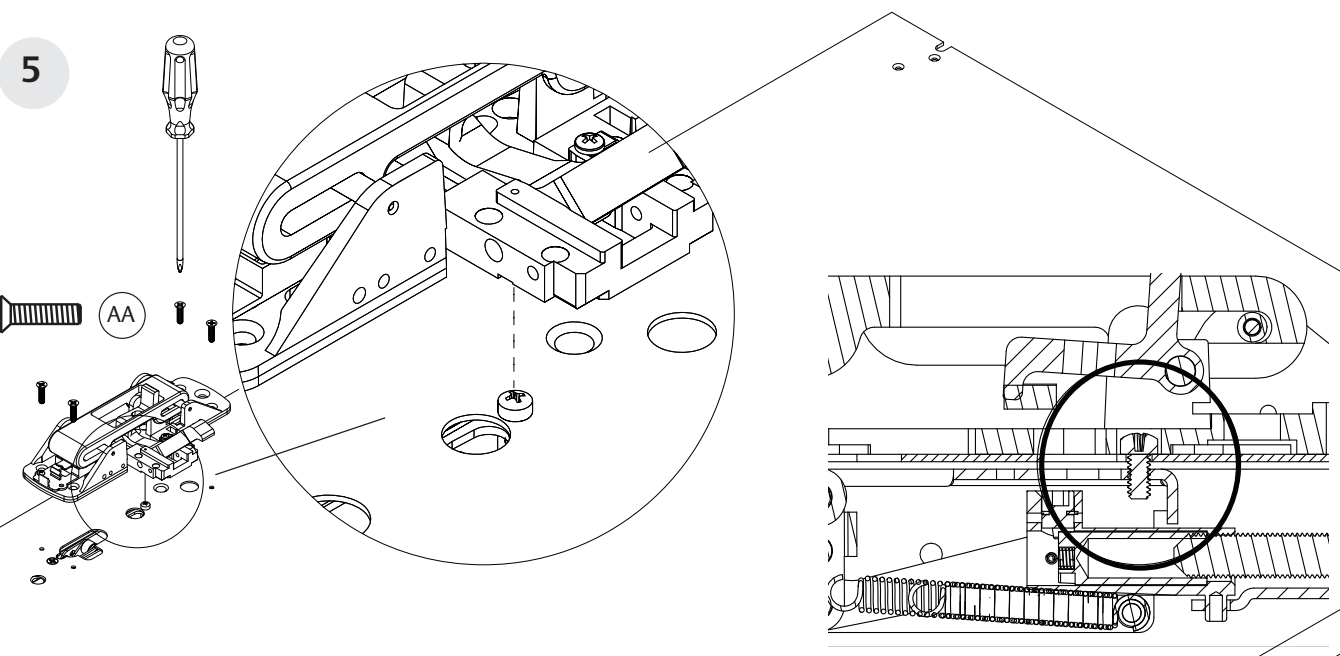

AA

FF

Locate chassis on the fillister head screw (FF). Attach to the door with (4) #10-24 x 3/4 flat head screws (AA).  
**Do not fully tighten screws.**

## Concealed Vertical Rod Exit Devices

### Installation Instructions

6



#### Adjusting the top bolt and rod assembly

- 1/8" gap or less between door top and frame: Rotate bolt to make it even with the top of the door.
- 1/8" gap or greater: Bolt must extend above the door, equal to the gap, minus 1/8".

#### Adjusting the bottom bolt and rod assembly (Not needed for NB exit devices)

- 1/8" gap or less between door bottom and high point: Rotate bolt to make it even with the top of the door.
- 1/8" gap or greater: Bolt must extend below the door, equal to the gap, minus 1/8".

**Note:** Rod must be retracted while adjusting bolt projection. Depress chassis lift arm to retract top bolt and rod assembly.

A8305-1 5/23

# PE8600 Series (12-MD, MD, & AD)

## Concealed Vertical Rod Exit Devices

### Installation Instructions

**SARGENT**

**ASSA ABLOY**

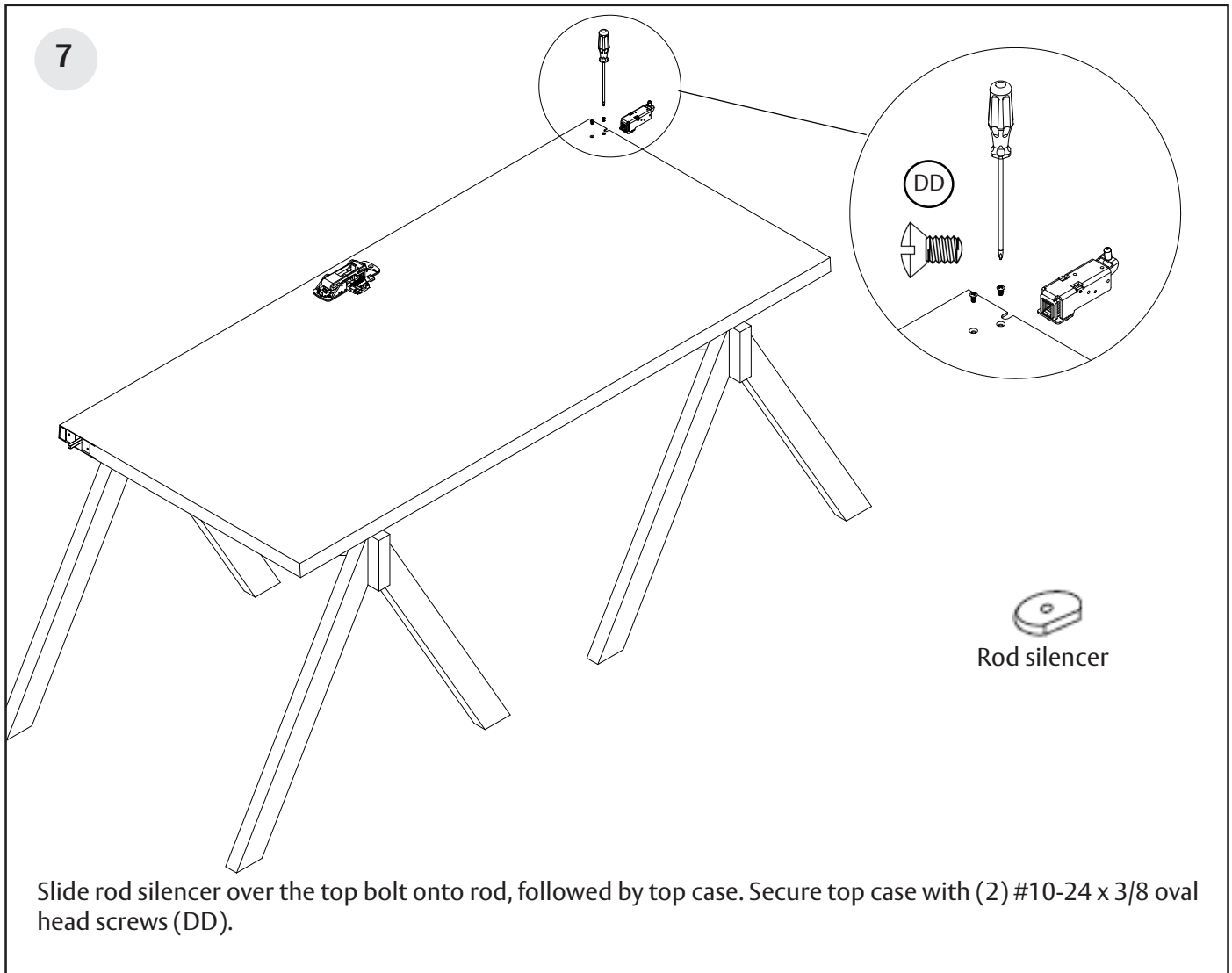

# PE8600 Series (12-MD, MD, & AD)

**SARGENT**

**ASSA ABLOY**

## Concealed Vertical Rod Exit Devices

### Installation Instructions

8



For AD- application

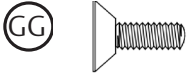

For MD- and 12-MD- application

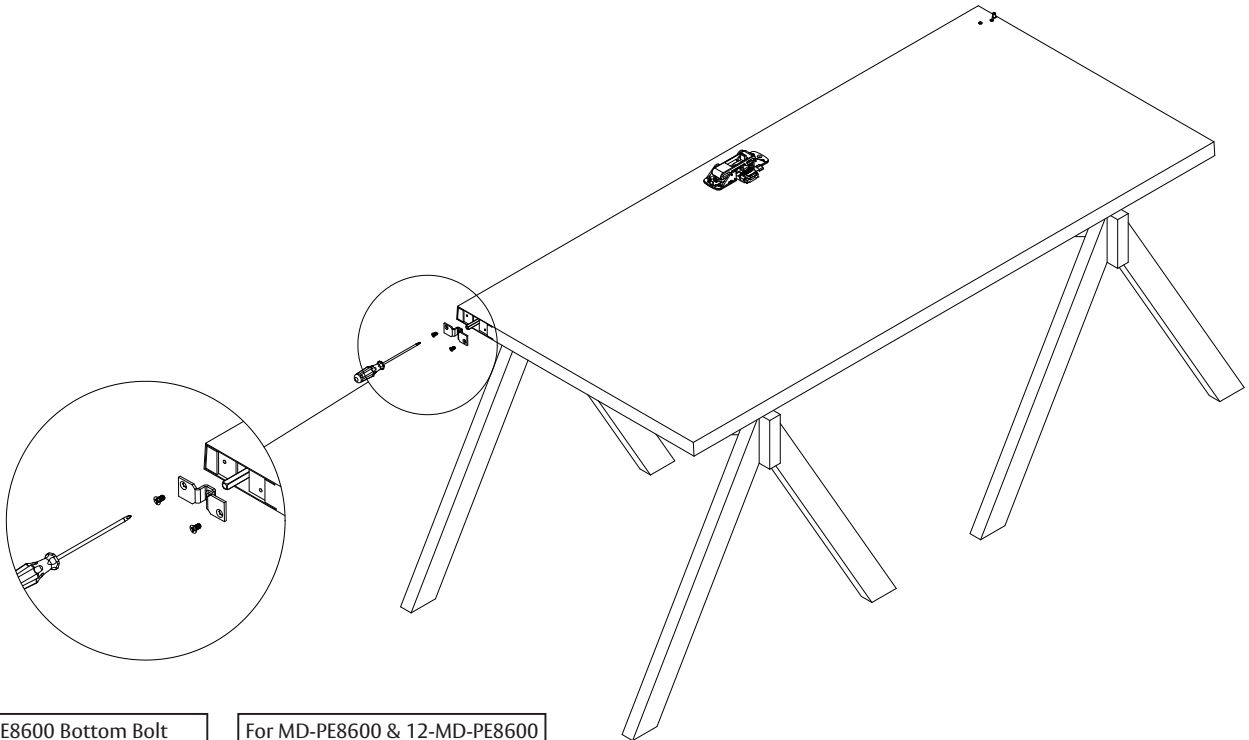

For AD-PE8600 Bottom Bolt  
Install bottom plate over  
the bottom bolt and  
secure with two #10-24 x 3/8"  
oval head screws (DD) using  
holes.

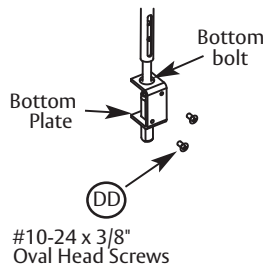

For MD-PE8600 & 12-MD-PE8600  
Bottom Bolt  
Install bottom plate over  
the bottom bolt and secure  
with two 1/4-20 x 1/2"  
flat head screws (GG) using  
tapped holes.

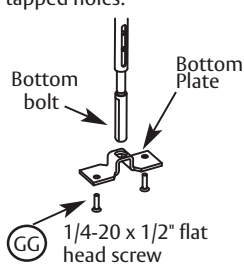

\*Bottom plate and screws not included with NB- option.

Install bottom bracket over the bottom bolt and secure with two 1/4-20 x 1/2" flat head screws (GG).  
For AD-PE8600 use (2) #10-24 x 3/8 oval head screws (DD) on the face of the door.

# PE8600 Series (12-MD, MD, & AD)

## Concealed Vertical Rod Exit Devices

### Installation Instructions

**SARGENT**

**ASSA ABLOY**

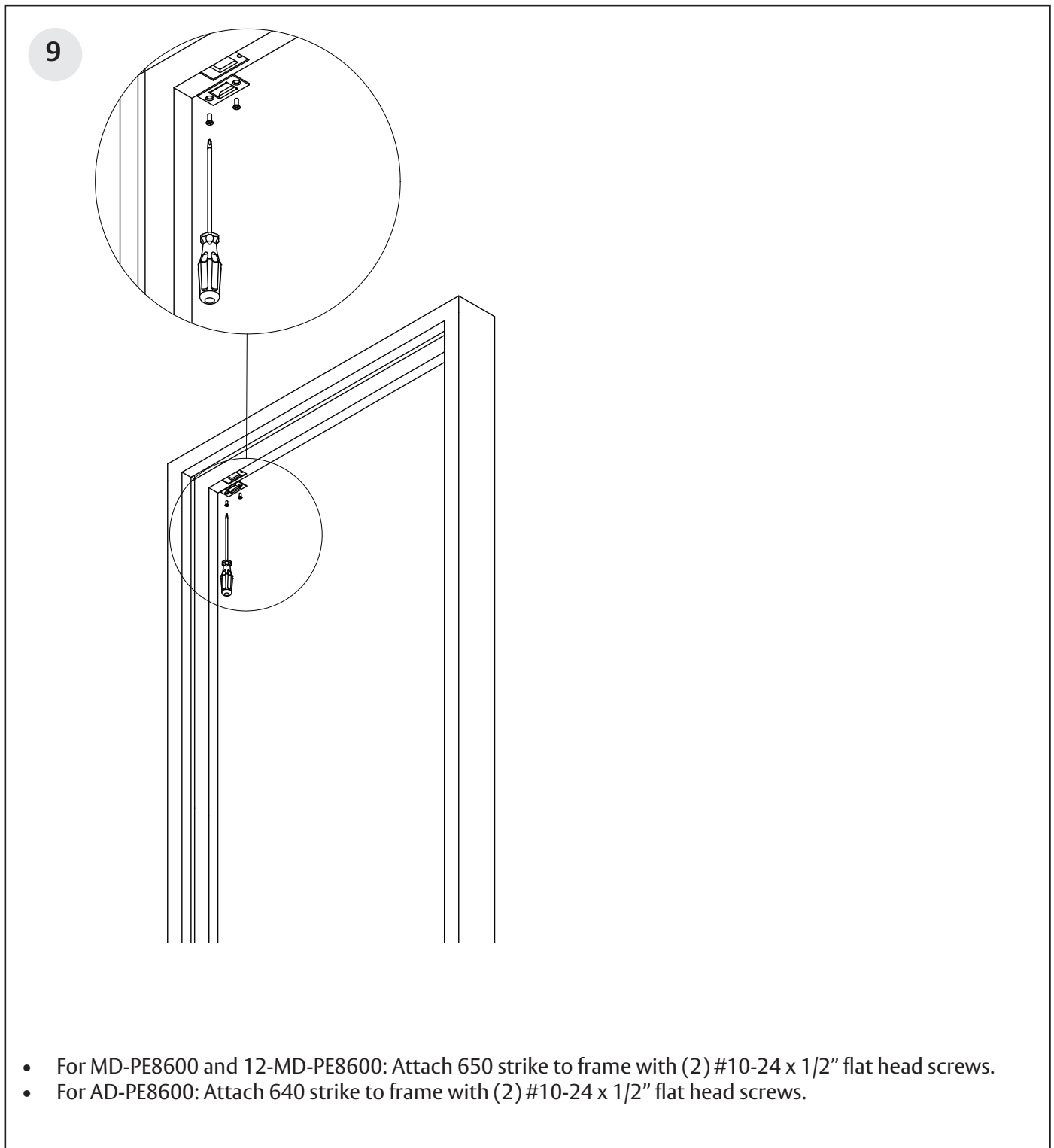

# PE8600 Series (12-MD, MD, & AD)

## Concealed Vertical Rod Exit Devices

### Installation Instructions

**SARGENT**

**ASSA ABLOY**

10

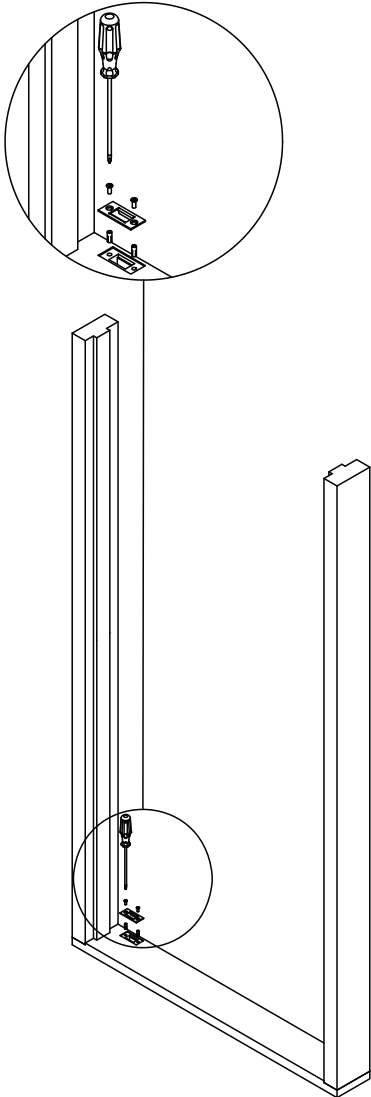

- For MD-PE8600: Attach 650 bottom strike to floor with anchors and supplied fasteners.
- For 12-MD-PE8600 attach 606 bottom strike to floor with anchors and supplied fasteners.
- For AD-PE8600: Attach 640 strike to threshold with supplied fasteners.

11

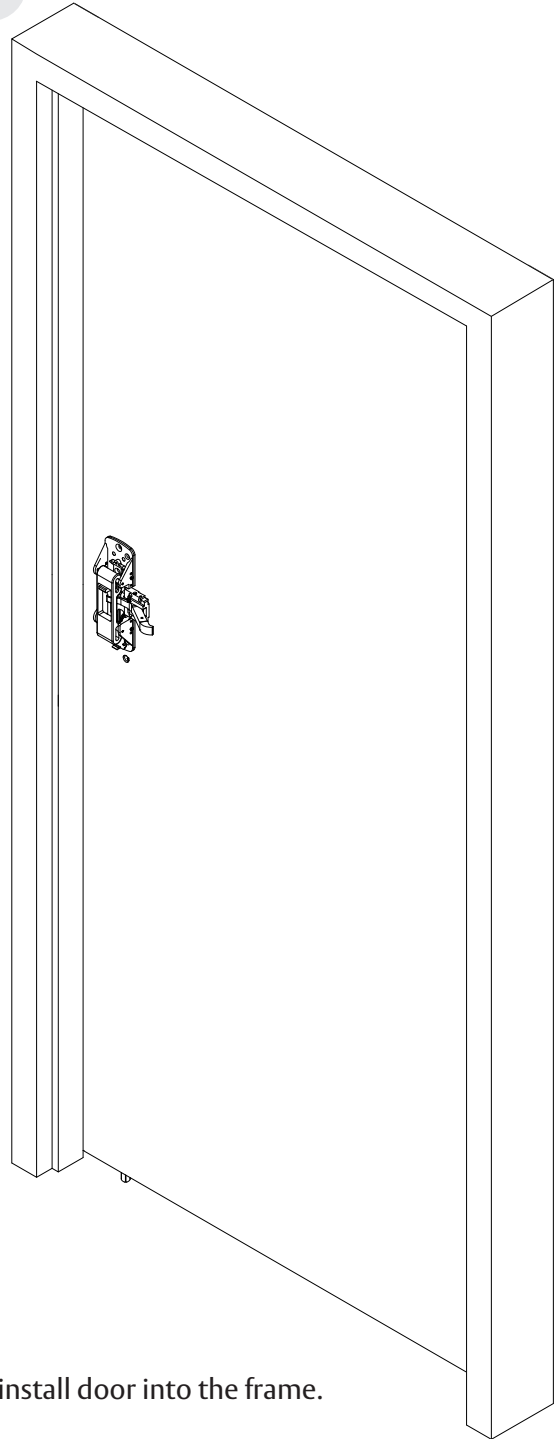

Reinstall door into the frame.

A8305-1 5/23

# PE8600 Series (12-MD, MD, & AD)

**SARGENT**

**ASSA ABLOY**

## Concealed Vertical Rod Exit Devices

### Installation Instructions

#### Rail cutting guide

If the rail doesn't need to be cut, continue to page 17 step 12.

If the rail must be cut, follow these steps on page 15 and 16:

Refer to the individual exit device installation instructions for rail cutting requirements / restrictions. Instructions will vary based on device type and options.

- Determine cut off dimension "X" by subtracting 2-7/8" from dimension "Y". Mark cut off point on mounting rail. (See below.)

 Do not cut closer than 1-5/8" from the the front edge of the rail insert.

Information for Cutting Rails		
Rail Sizes	Door Widths	
	Standard	Minimum
E	32"	24"
F	36"	33"
J	42"	37"
G	48"	43"

Verticle reference line (C of chassis)

For doors with stile rail, the stile must overlap by 5/16" min.

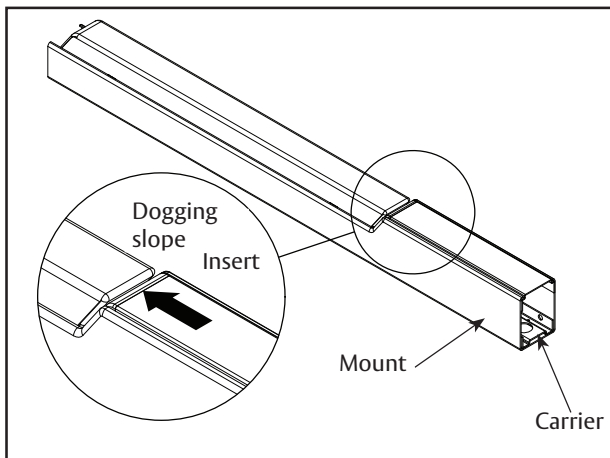
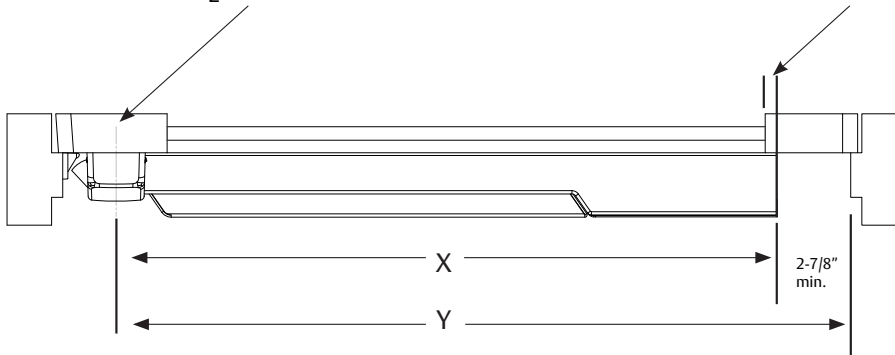

A. Ensure there isn't a gap between the insert and the dogging slope, and the carrier is flush with the mount.

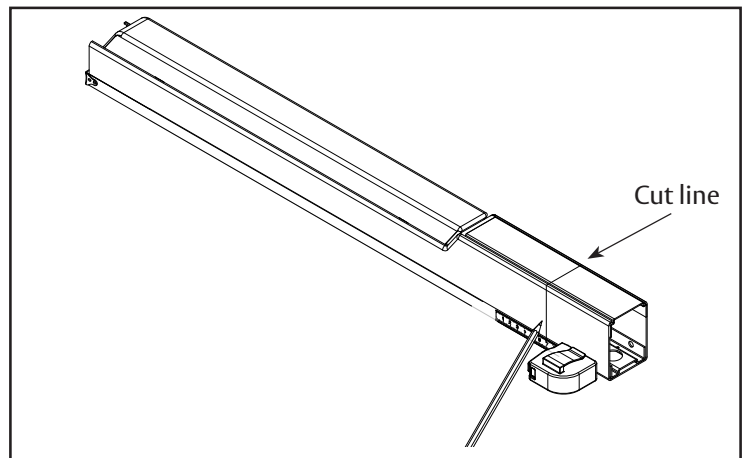

B. Mark rail at the required cut length.

# PE8600 Series (12-MD, MD, & AD)

**SARGENT**

**ASSA ABLOY**

## Concealed Vertical Rod Exit Devices

### Installation Instructions

### Rail cutting guide, continued.

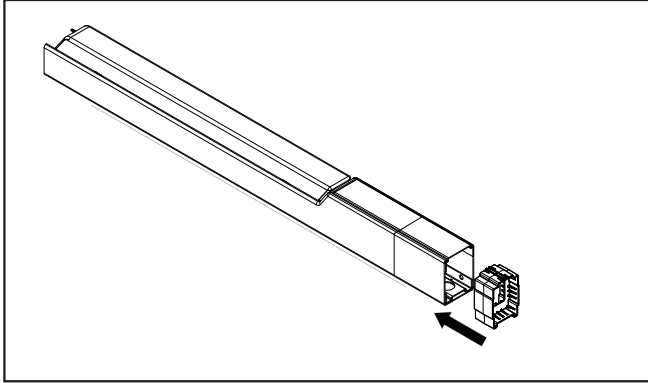

C. Ensure plastic insert support is installed under the cut line.

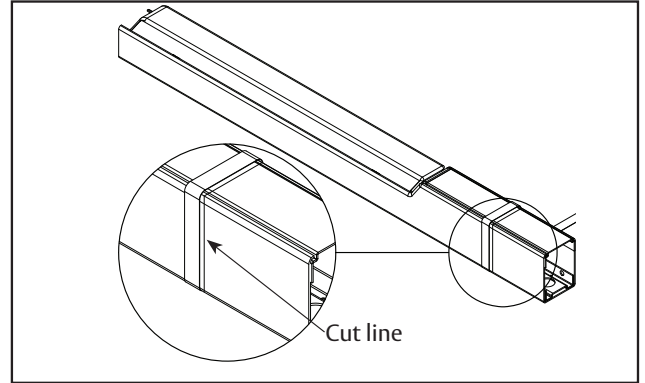

D. Wrap the rail and insert in masking tape, as shown.

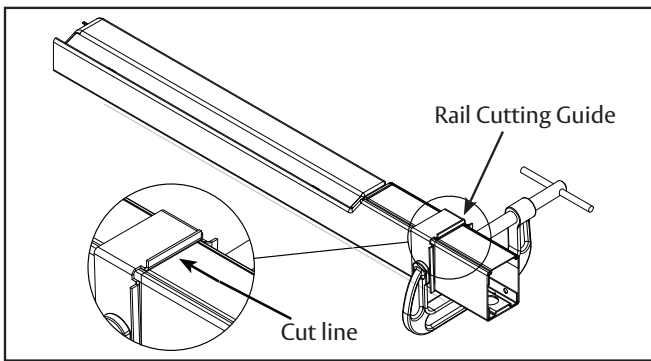

E. Place the rail cutting guide over the masking tape and align it with the cut line. Clamp the cut guide to the rail using a C-clamp.

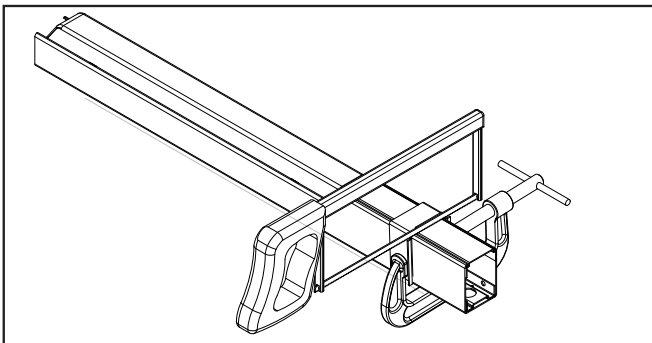

F. Using a hack saw with a new blade or a chop saw with a metal cutting blade, cut the rail, ensuring that the blade stays pressed against the rail cutting guide.

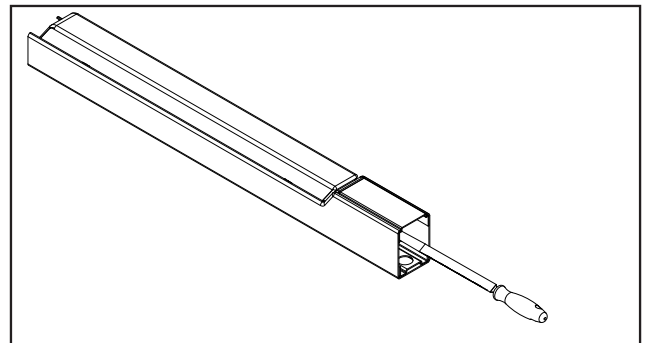

G. Deburr and smooth all cut edges with a file.



# PE8600 Series (12-MD, MD, & AD)

## Concealed Vertical Rod Exit Devices

### Installation Instructions

**SARGENT**

**ASSA ABLOY**

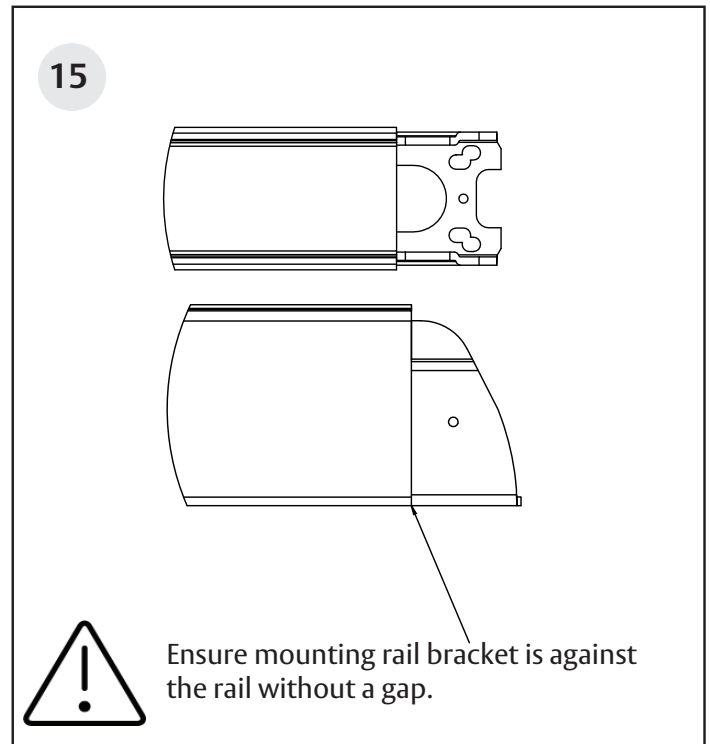
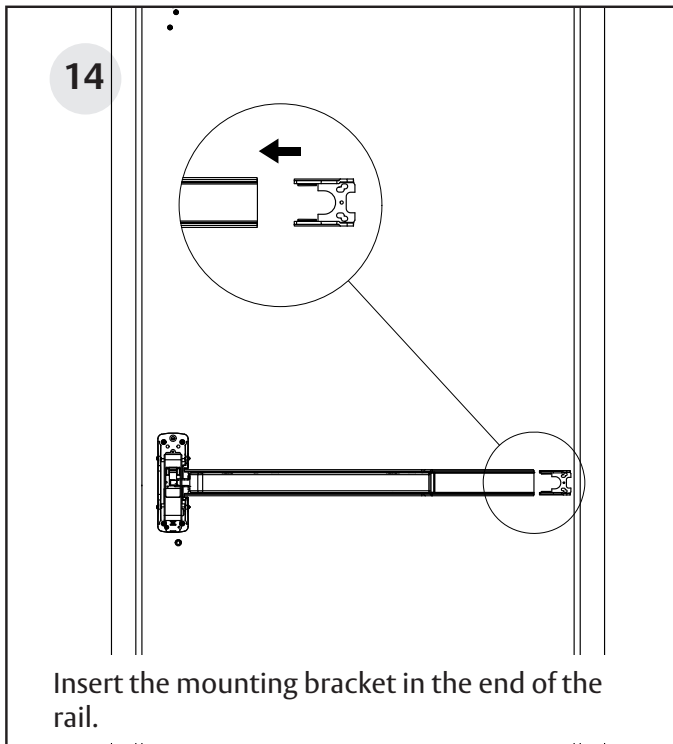
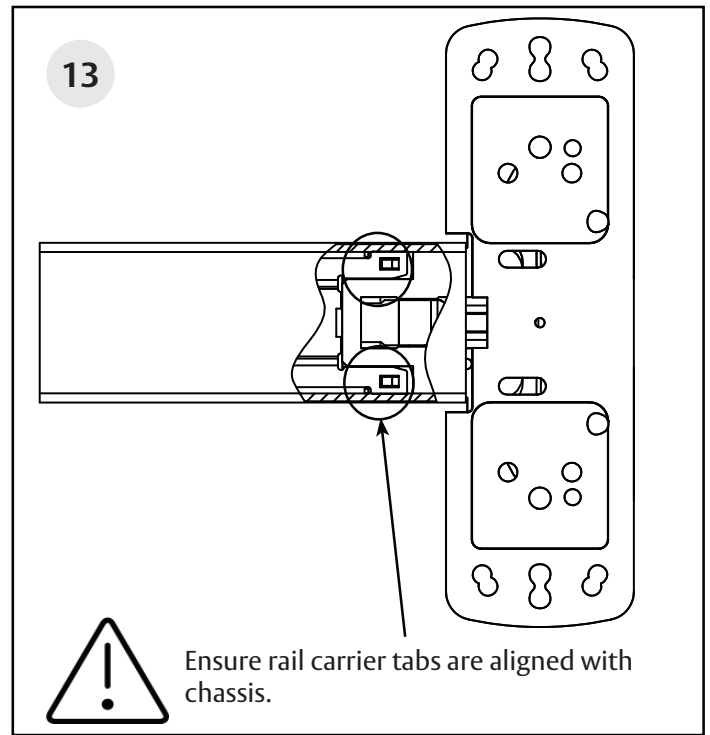
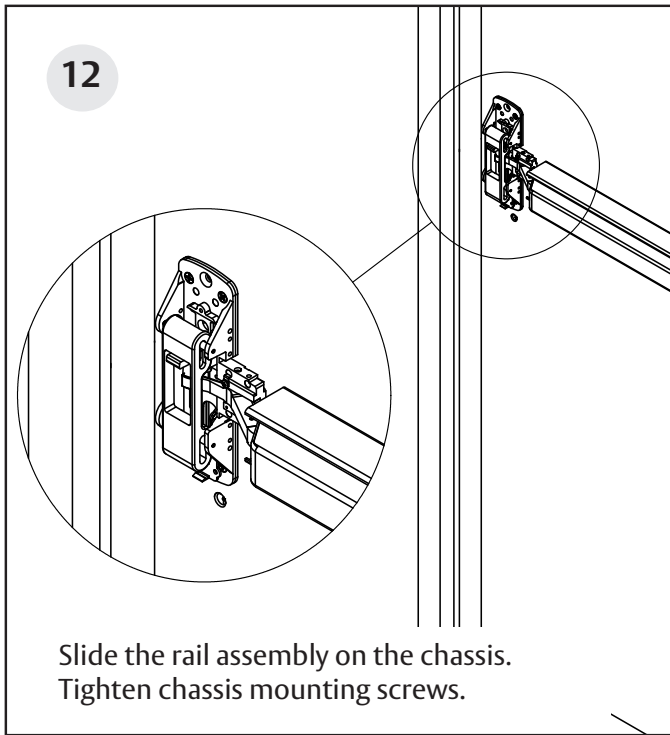

# PE8600 Series (12-MD, MD, & AD)

## Concealed Vertical Rod Exit Devices

### Installation Instructions

**SARGENT**

**ASSA ABLOY**

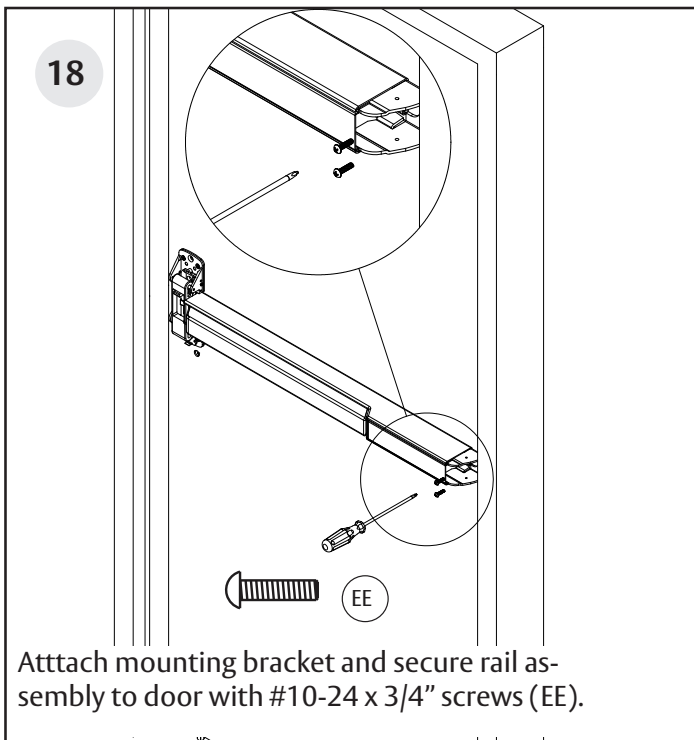
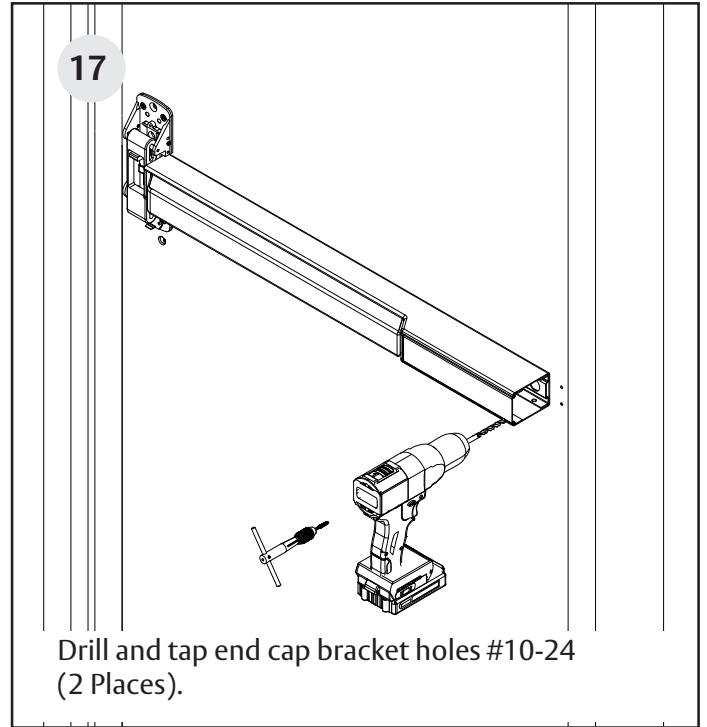
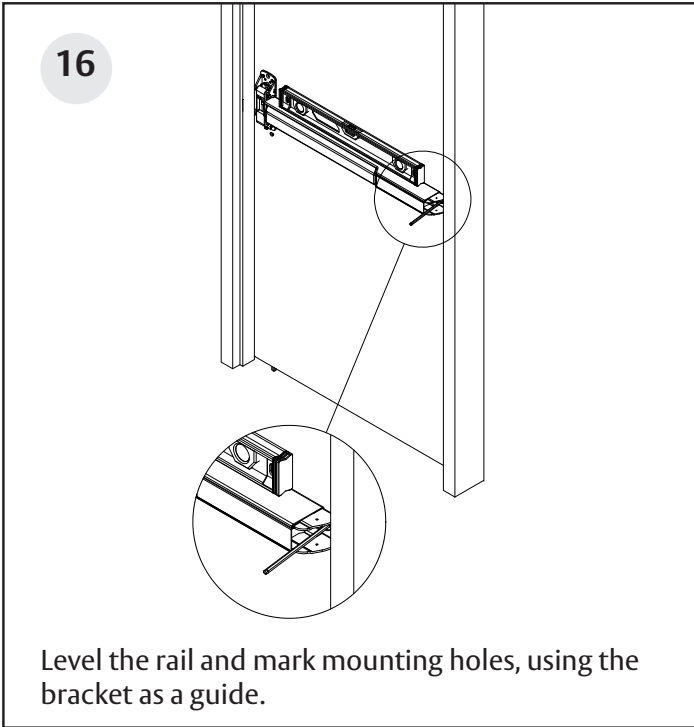

## Concealed Vertical Rod Exit Devices

### Installation Instructions

19

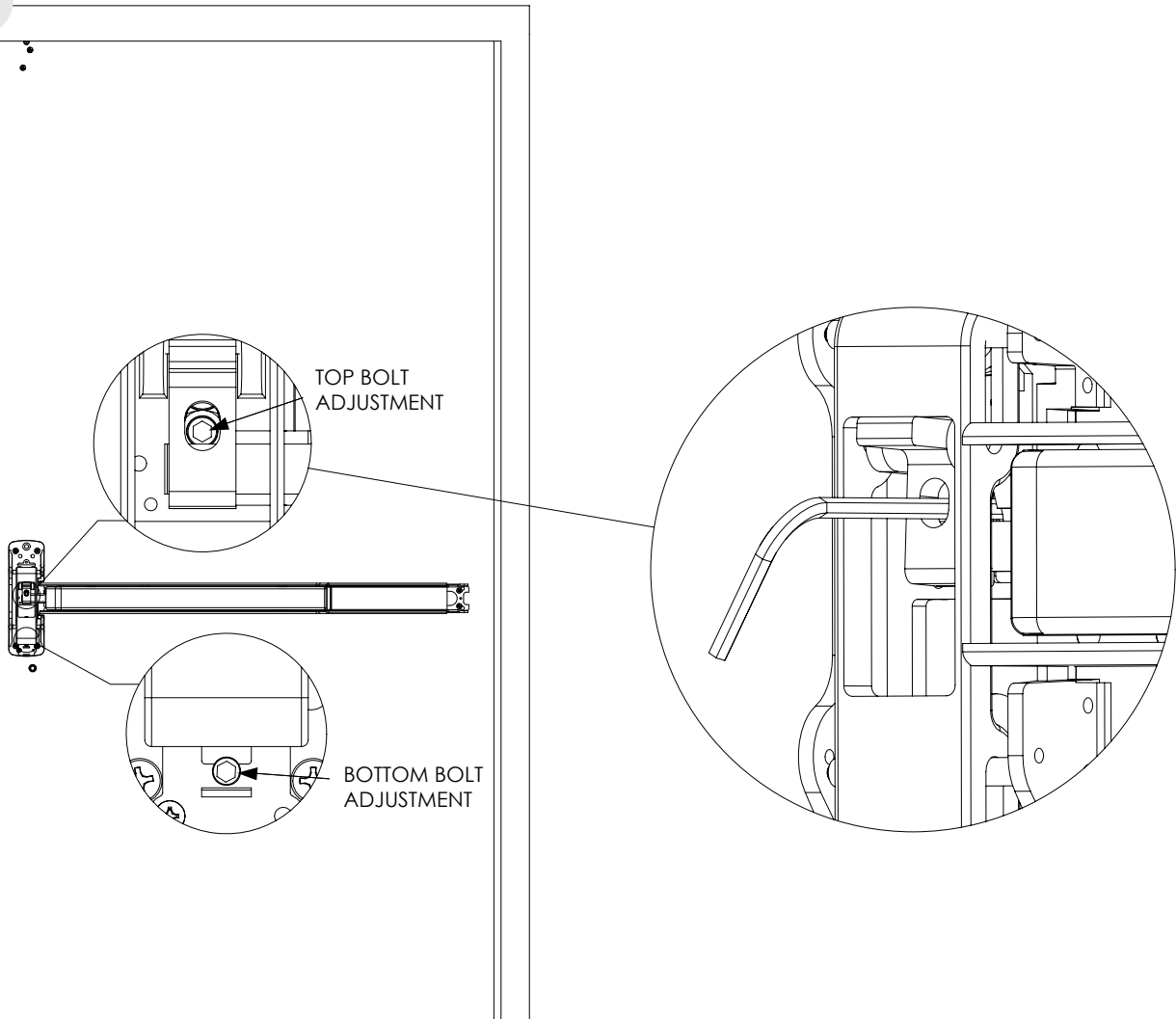

If adjustments are needed, before closing the door check the following:

- Push rail in to retract bolts.
- Bolts stay retracted (hold back).
- Bolts release when the door closes. The button inside the top of the door hits the frame.
- The bolt engages with the strike  $1/4'' - 5/16''$ .

For final adjustment close door to adjust.

- Use  $5/32''$  Allen wrench to adjust projection. Turn clockwise to adjust the bolt back into the door. Turn counter clockwise to extend the bolt.

