

Installation Instructions

SARGENT
ASSA ABLOY

FM-PE8700 Series (12- and Standard)

Surface Vertical Rod Exit Devices

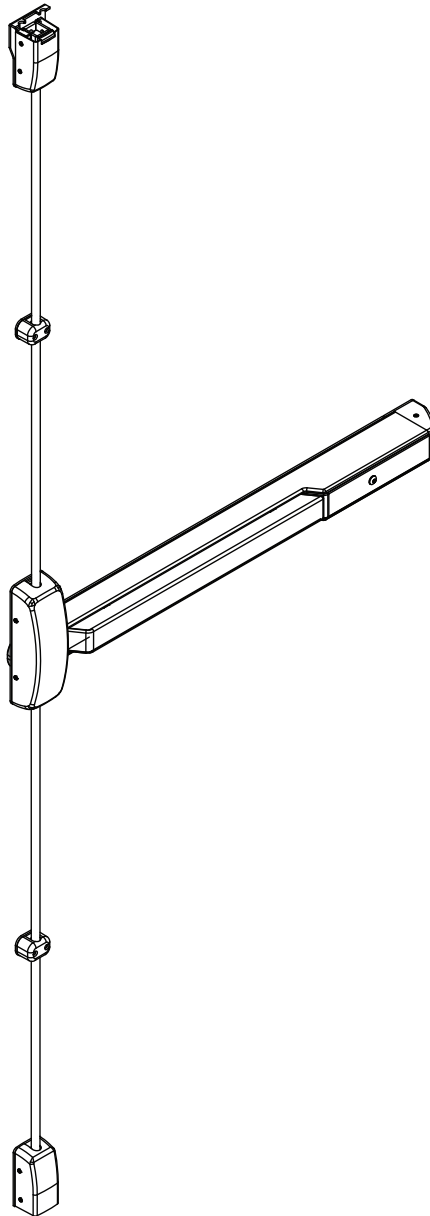

WARNING

This product can expose you to lead which is known to the state of California to cause cancer and birth defects or other reproductive harm. For more information go to www.P65warnings.ca.gov.

WARNING

Attention Installer: Improper installation may result in damage to the product and void the factory warranty.

1-800-727-5477 • www.sargentlock.com

Copyright © 2023, SARGENT Manufacturing Company. All rights reserved. Reproduction in whole or in part without the express written permission of SARGENT Manufacturing Company is prohibited. Patent pending and/or patent www.assaabloyds.com/patents.

A8319-1 5/23

Experience a safer
and more open world

FM-PE8700 Series

Surface Vertical Rod Exit Device

Installation Instructions

Screw Chart



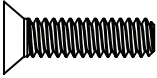
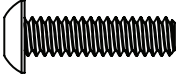
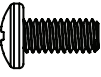
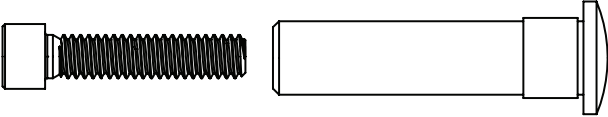
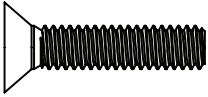
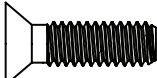
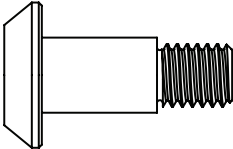
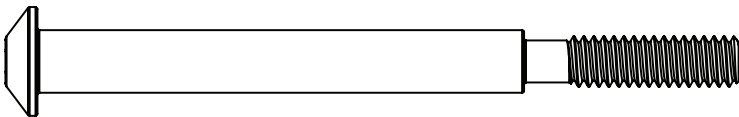

DESCRIPTION	TOTAL QTY SUPPLIED	WHERE USED
 #10-24 X 3/4" FLAT HEAD MACHINE SCREW	4	(4) CHASSIS CORNER MOUNTING HOLES
 #10-24 X 3/4" ROUND HEAD SOCKET SCREW	2	(2) REAR MOUNTING PLATE
 #8-32 X 3/8" TRUSS HEAD MACHINE SCREW	2	(2) CHASSIS TO MOUNT RAIL
 #12-24 X 3/4" SOCKET HEAD CAP SCREW WITH MORTISE NUT	4	(2) TOP CASE TOP MOUNTING HOLES (2) BOTTOM CASE BOTTOM MOUNTING HOLES
 #12-24 X 1" FLAT HEAD SOCKET SCREW	4	(2) TOP CASE BOTTOM MOUNTING HOLES (2) BOTTOM CASE TOP MOUNTING HOLES
 #12-24 X 3/4" FLAT HEAD MACHINE SCREW	5	(1) TOP CASE SHIM (4) 659 TOP LATCH STRIKE
 RAIL RETAINER BOLT	1	(1) MOUNT RAIL / CARRIER TO DOOR
 1/4"-20 SHOULDER BOLT	1	(1) THRU INSERT

FM-PE8700 Series

Surface Vertical Rod Exit Device

Installation Instructions

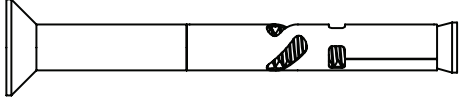
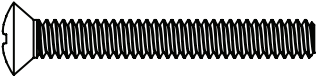
Screw Chart

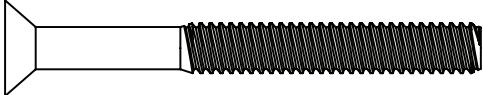
DESCRIPTION	TOTAL QTY SUPPLIED	WHERE USED
 <p>1/4" SLEEVE ANCHOR</p>	3	(3) 653 BOTTOM STRIKE
 <p>#10-24 X 1-1/2" OVAL HEAD MACHINE SCREW</p>	4	(2) TOP ROD GUIDE (2) BOTTOM ROD GUIDE
 <p>#8-32 X 5/16" W/ #6 OVAL HEAD MACHINE SCREW</p>	14	(4) CHASSIS COVER (2) END CAP (4) TOP CASE COVER (4) BOTTOM CASE COVER
 <p>1/4"-20 X 2-3/8" KNURLED FLAT HEAD MACHINE SCREW</p>	2	(2) EXIT TRIM (IF USED)

FM-PE8700 Series

Surface Vertical Rod Exit Device

Installation Instructions



Tools Needed

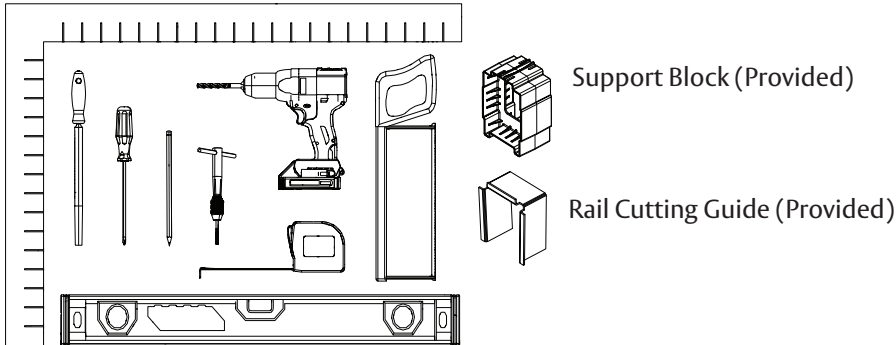

Before installation:

1. Install mullion, if used.
2. Fit and hang door.
3. Check the box's label for the size of the exit device.

Note: Please refer to trim and other installation instructions provided in the box.



The surface of the door where the exit device is to be applied must be flush. Clear away any raised projections to allow exit device to rest on the flat surface of the door. If shim kit is required, contact your distributor.

Handing

All FM-PE8700 series exit devices are handed, except the FM-PE8710, which is field reversible. The FM-PE8710 is shipped as LHR unless ordered as RHR.

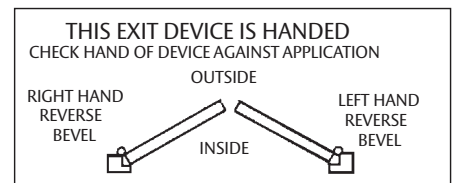

To Change Hand of an FM-PE8700 Exit Device:

1. Remove both chassis pins and main slide.
2. Remove lift lever pin and lift lever.
3. Rotate chassis 180° and reposition lift lever and lift lever pin as shown below
4. Position main slide with large end of main slide at the bottom and retain with chassis pins.

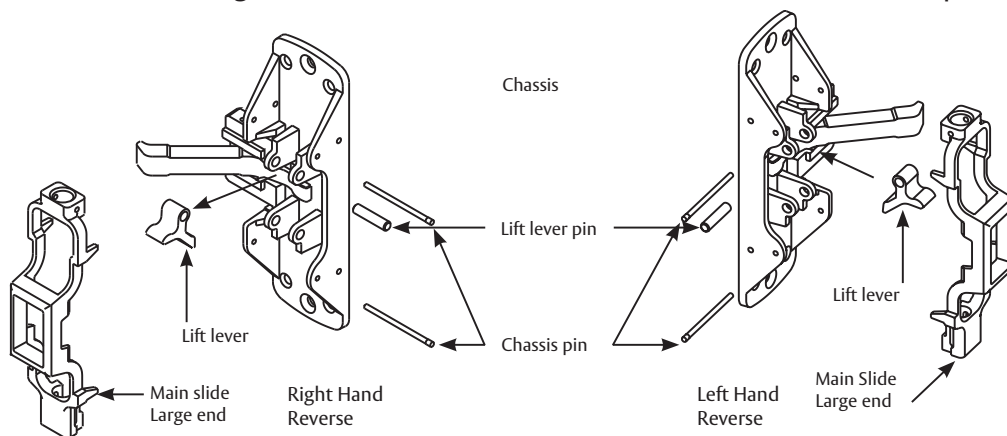

FM-PE8700 Series

Surface Vertical Rod Exit Device

Installation Instructions



Product Overview

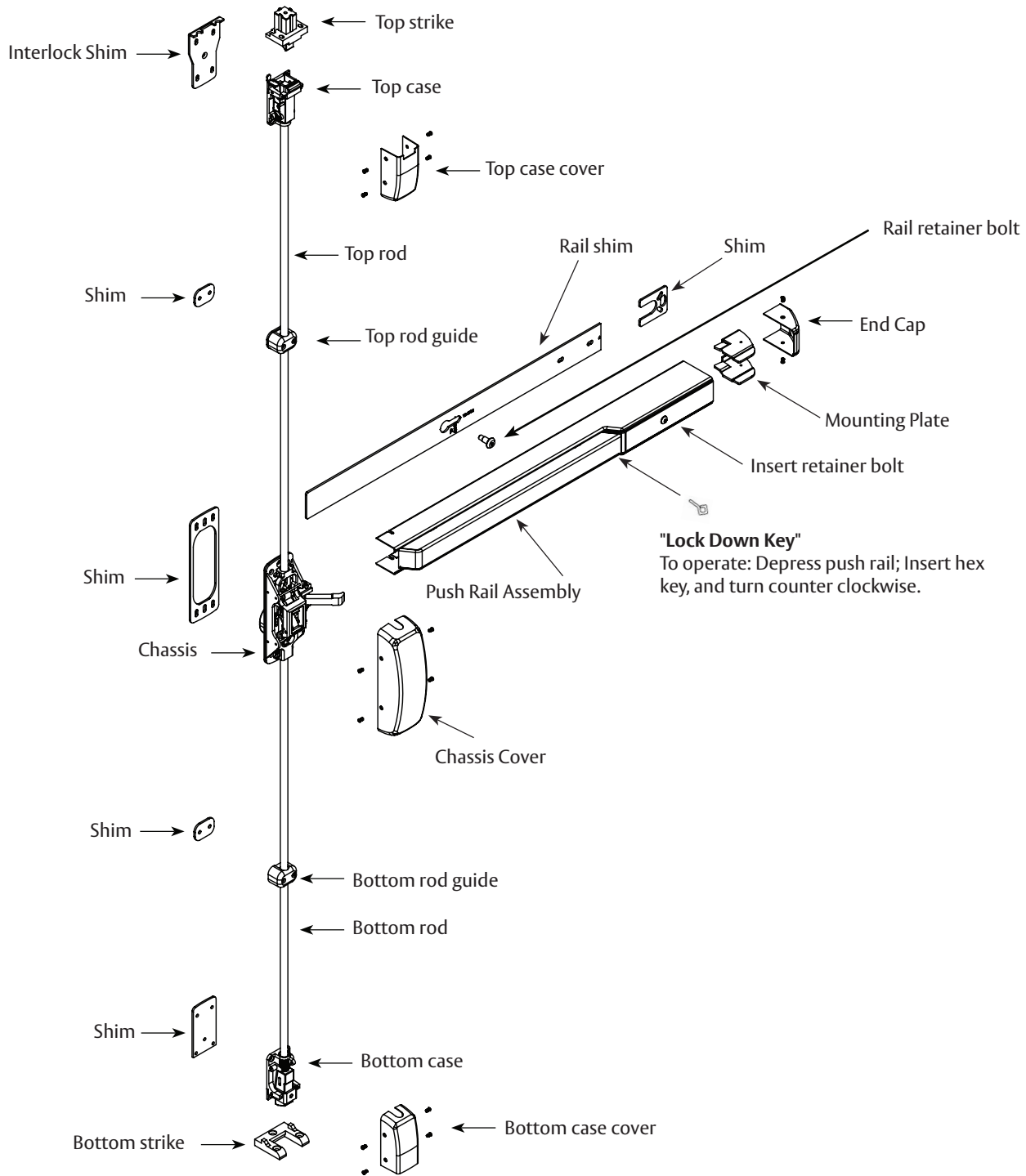

FM-PE8700 Series

Surface Vertical Rod Exit Device

Installation Instructions

SARGENT

ASSA ABLOY

1

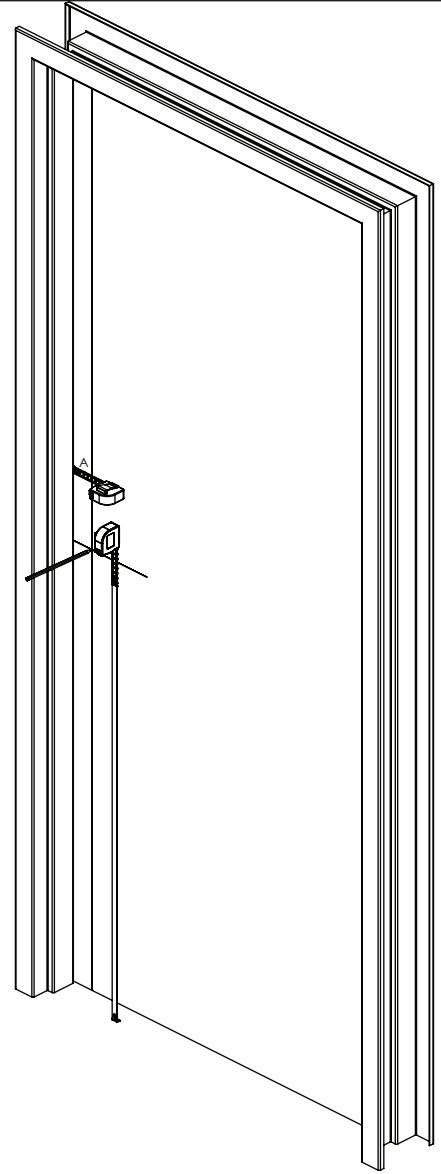

- With door closed, measure and mark 2-3/4" to locate the vertical reference center line of the chassis, top case, and bottom case.
- Horizontal reference line is rail centerline height. Standard rail centerline height is 39-5/8" above the finished floor.

2

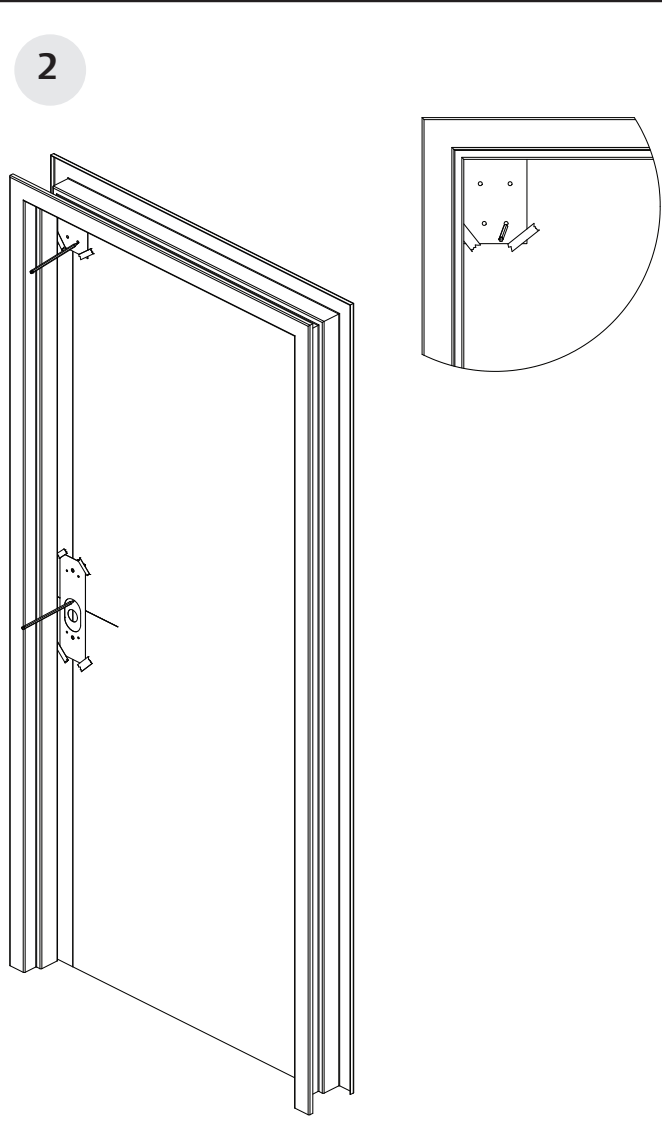

- With door closed, tape template for chassis / trim on inside of door, along vertical and horizontal reference lines.
- Fold top case / top strike template and tape on inside of door along vertical reference lines.

FM-PE8700 Series

Surface Vertical Rod Exit Device

Installation Instructions

SARGENT

ASSA ABLOY

3

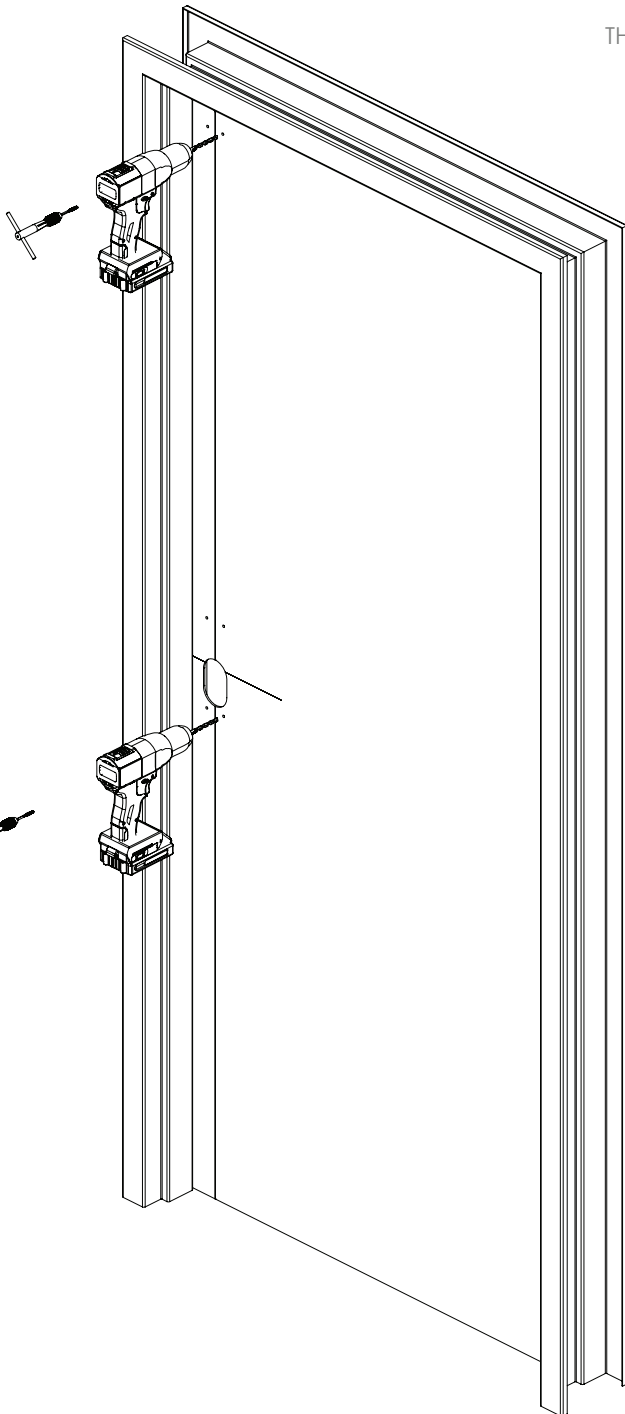

2X $\varnothing \frac{3}{8}$ "
THRU BOTH SIDES

2X #12-24
TAPPED HOLES
THIS SIDE ONLY

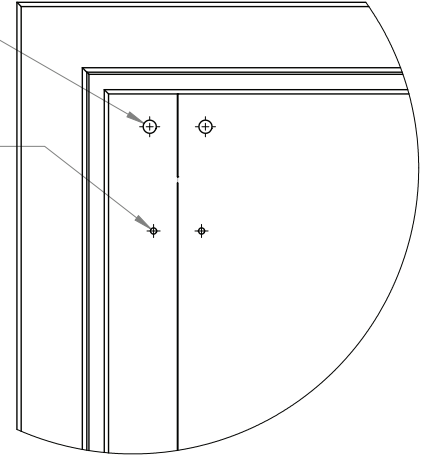

- Spot and drill all holes from inside of door.
- If needed, prepare pockets for outside trim. See installation instructions supplied with trim for details.

NOTE: Any holes drilled from the outside need pilot holes drilled from the inside to ensure good alignment.

NOTE: For electrical trim applications, ensure access to a raceway from the trim to the electric hinge or armored door loop.

FM-PE8700 Series

Surface Vertical Rod Exit Device

Installation Instructions

SARGENT

ASSA ABLOY

4

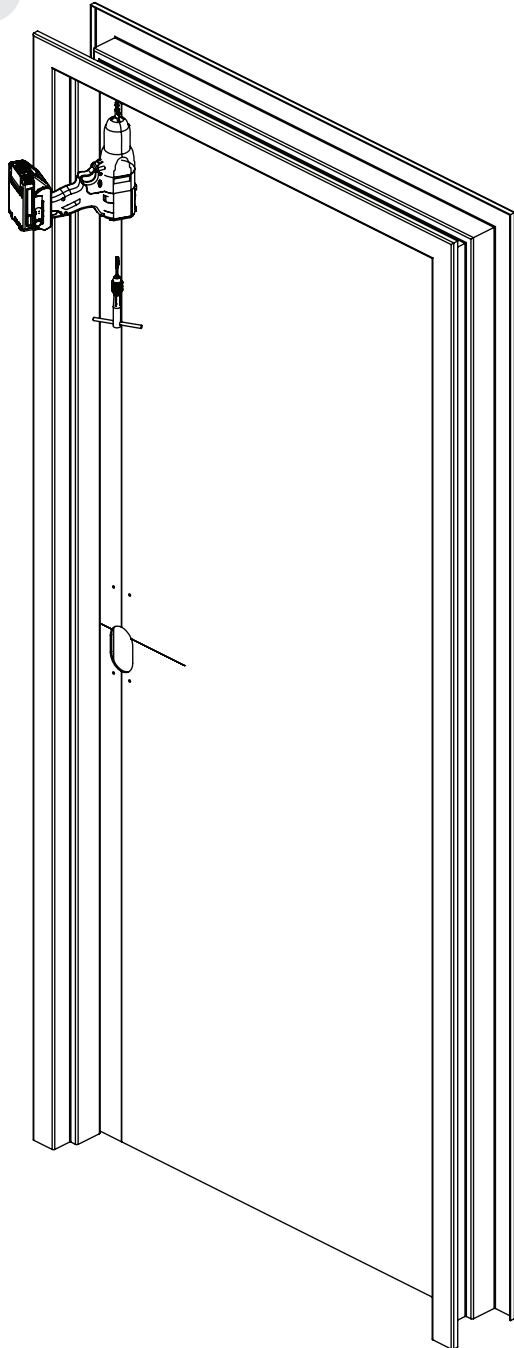

Frame Cutout

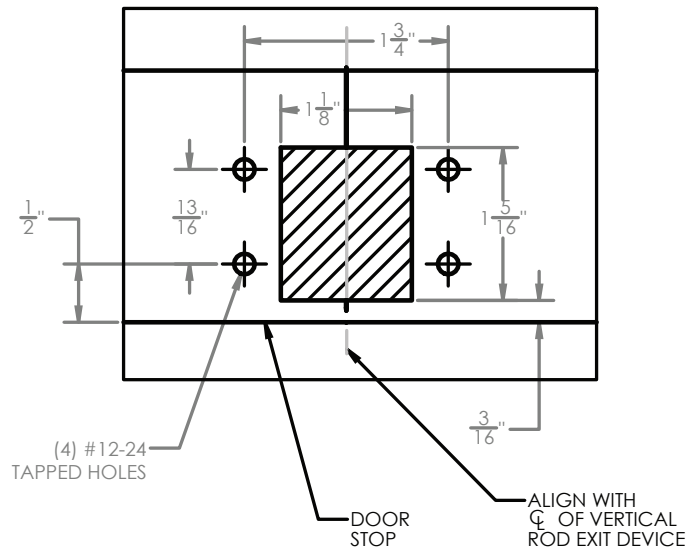

RECOMMENDED CUT-OUT IN FRAME FOR 659 TOP BOLT/STRIKE. THIS CUT OUT IS LARGE ENOUGH FOR FUTURE ADJUSTMENT.

- Transfer vertical centerline to door frame. Prepare rectangular cut-out in frame for top strike.
- Insert top strike. With door closed, align the interlocking shim with the top strike and place on the vertical reference line. Mark and drill four mounting holes using 11/64" drill and #12-24 tap.

FM-PE8700 Series

Surface Vertical Rod Exit Device

Installation Instructions

SARGENT

ASSA ABLOY

5

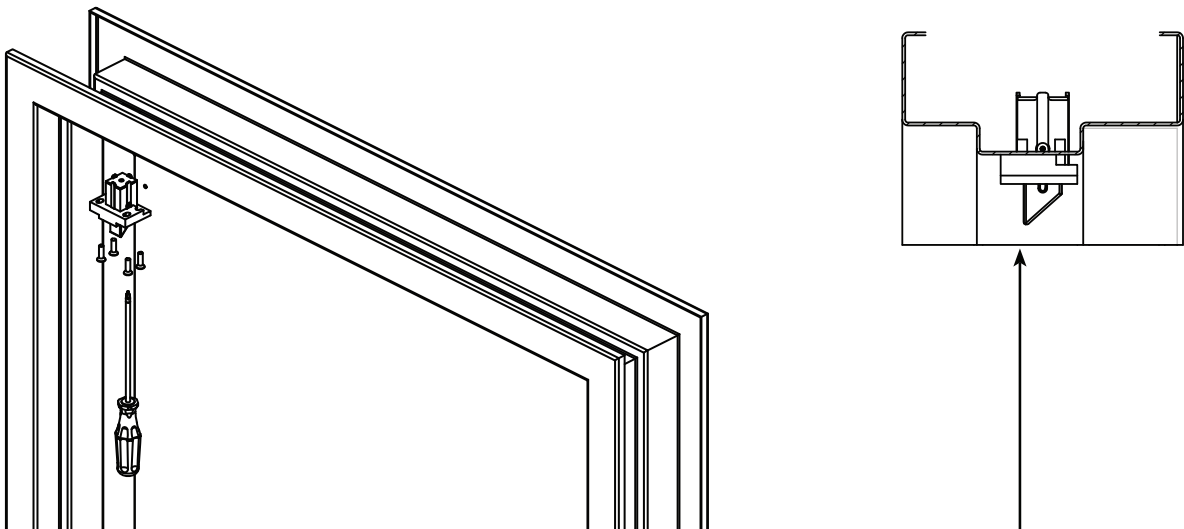

Mount top strike, (4) #12-24 x 3/4" phillips flat head machine screws. Flat side of top bolt should be facing away from the door.

Note: All four fasteners required. **DO NOT TIGHTEN FULLY.**

6

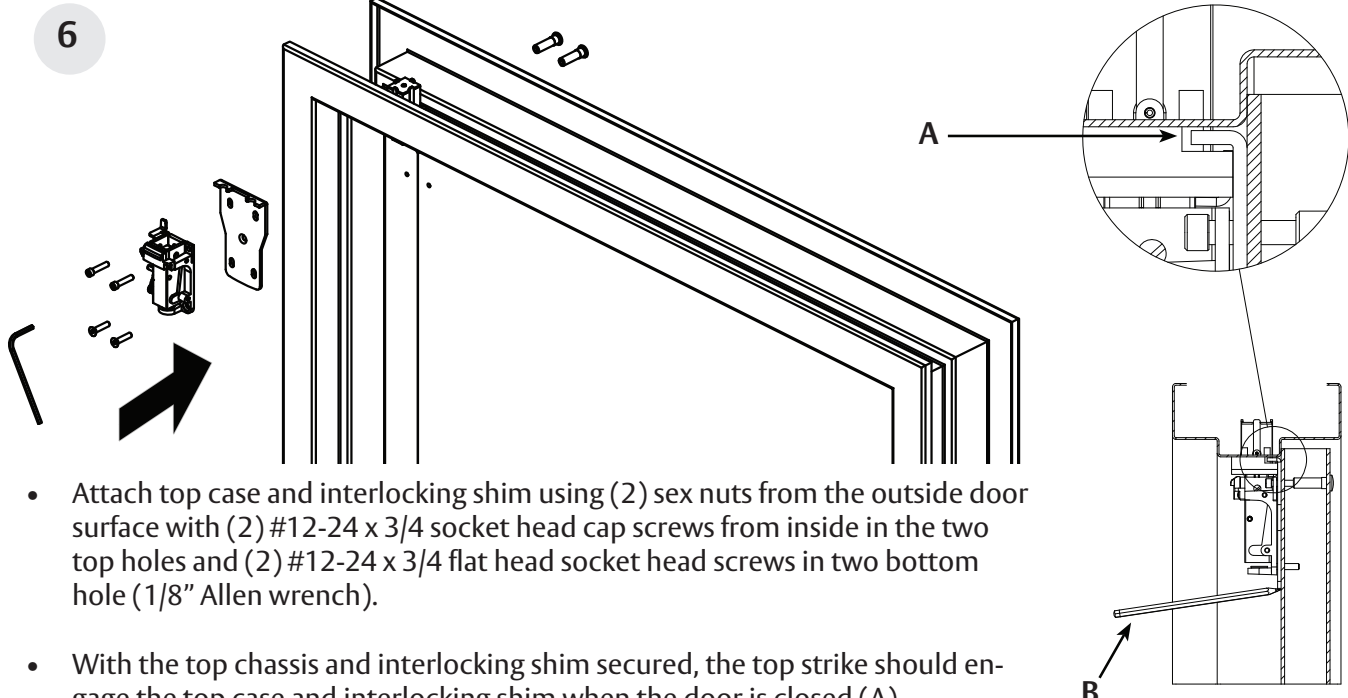

- Attach top case and interlocking shim using (2) sex nuts from the outside door surface with (2) #12-24 x 3/4 socket head cap screws from inside in the two top holes and (2) #12-24 x 3/4 flat head socket head screws in two bottom hole (1/8" Allen wrench).
- With the top chassis and interlocking shim secured, the top strike should engage the top case and interlocking shim when the door is closed (A).
- Trace the outline of the interlocking shim (B).

FM-PE8700 Series

Surface Vertical Rod Exit Device

Installation Instructions

SARGENT

ASSA ABLOY

7

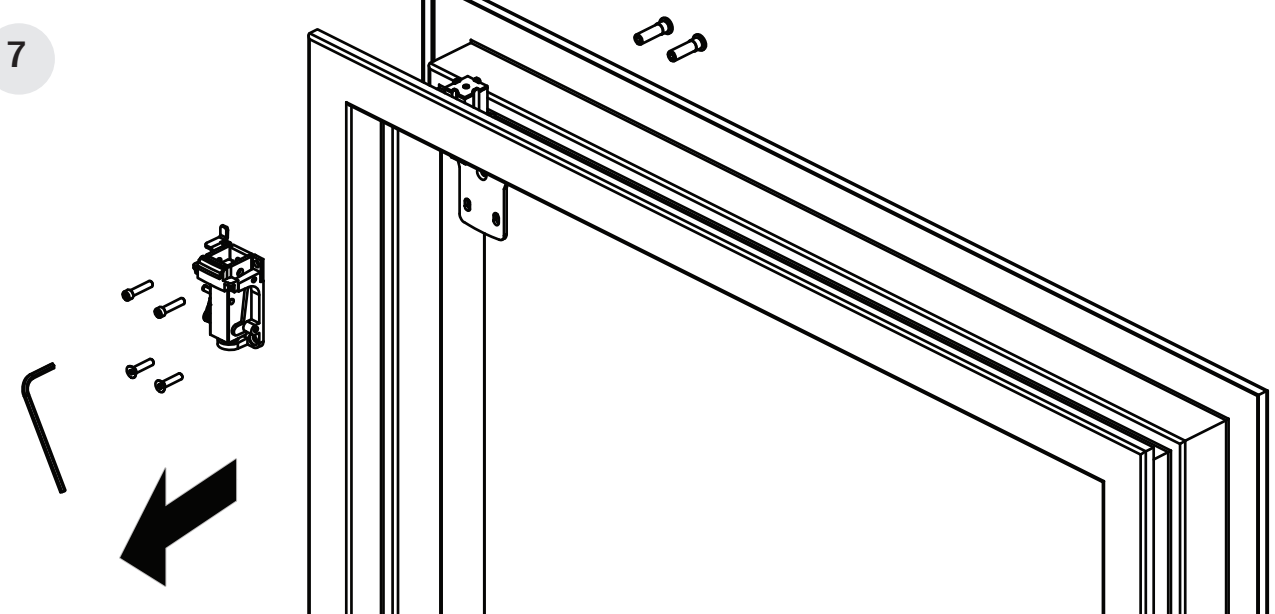

Remove the top case to expose the center hole on the Interlocking shim. **Ensure the interlocking shim is aligned with the tracing from Step 6.**

8

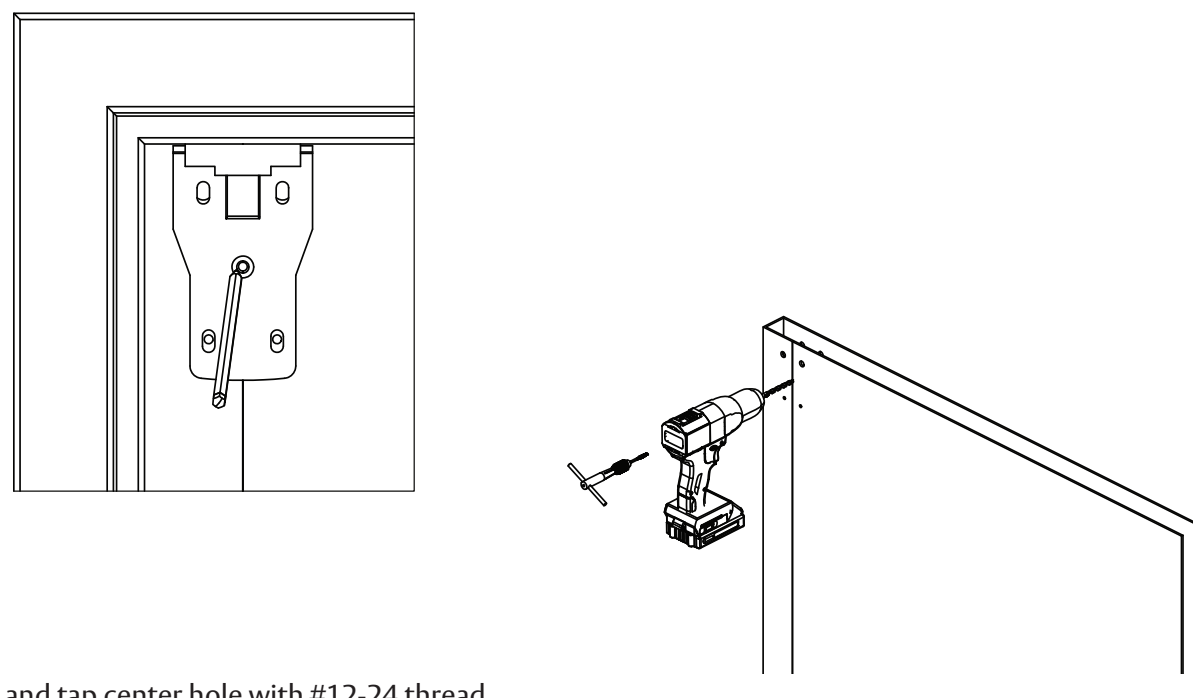

Mark and tap center hole with #12-24 thread.

FM-PE8700 Series

Surface Vertical Rod Exit Device

Installation Instructions

SARGENT

ASSA ABLOY

9

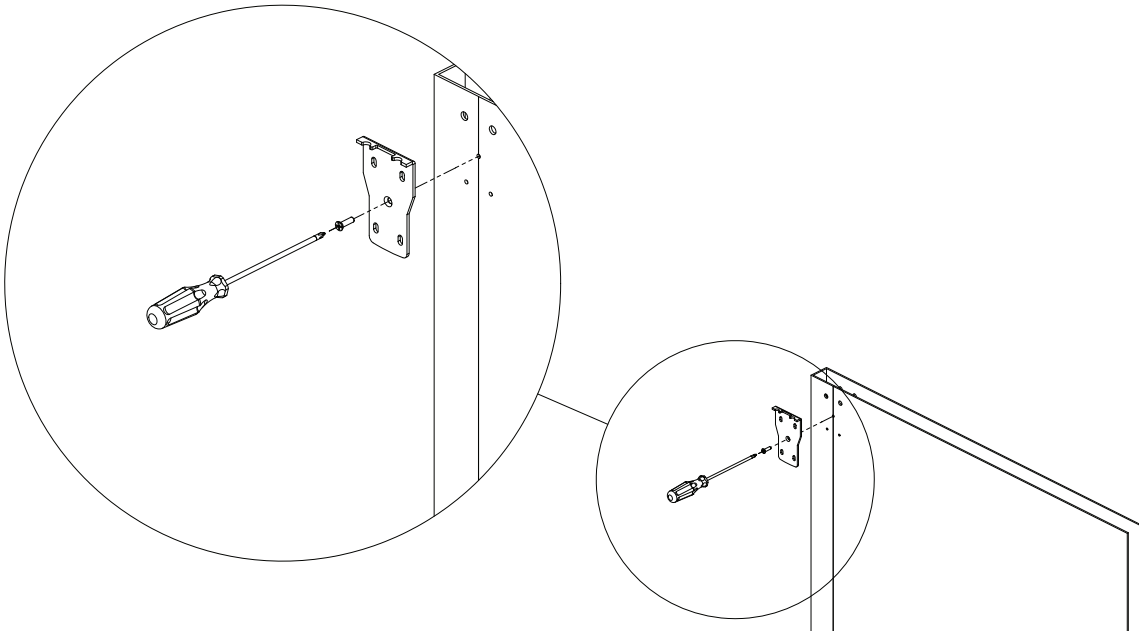

Attach interlocking shim with (1) #12-24 x 3/4" flat head socket head screw.

10

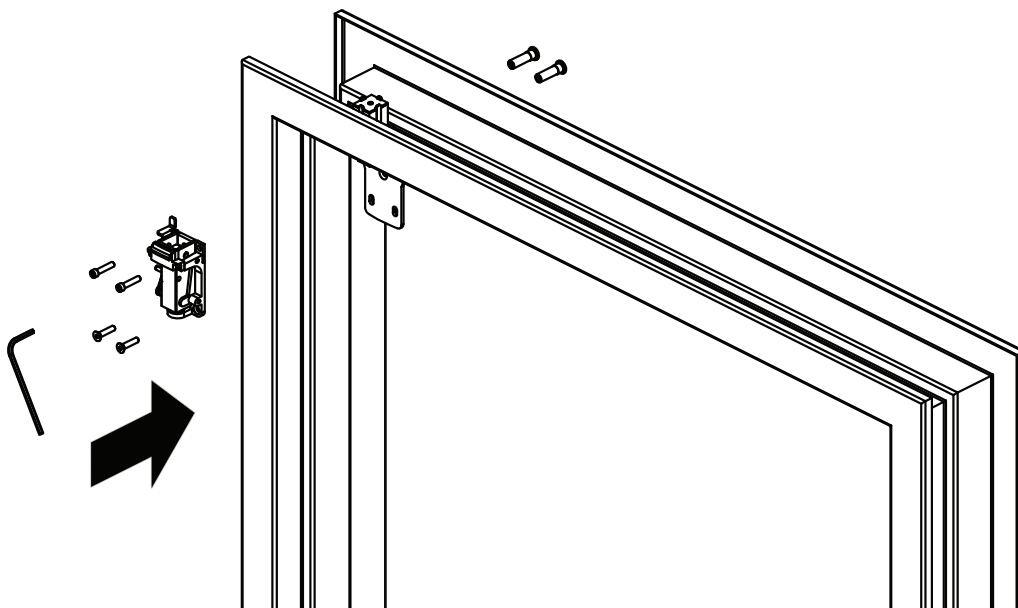

- Reinstall top case.
- Check for top case and top strike engagement.
- Tighten all screws.

FM-PE8700 Series

Surface Vertical Rod Exit Device

Installation Instructions

SARGENT

ASSA ABLOY

11

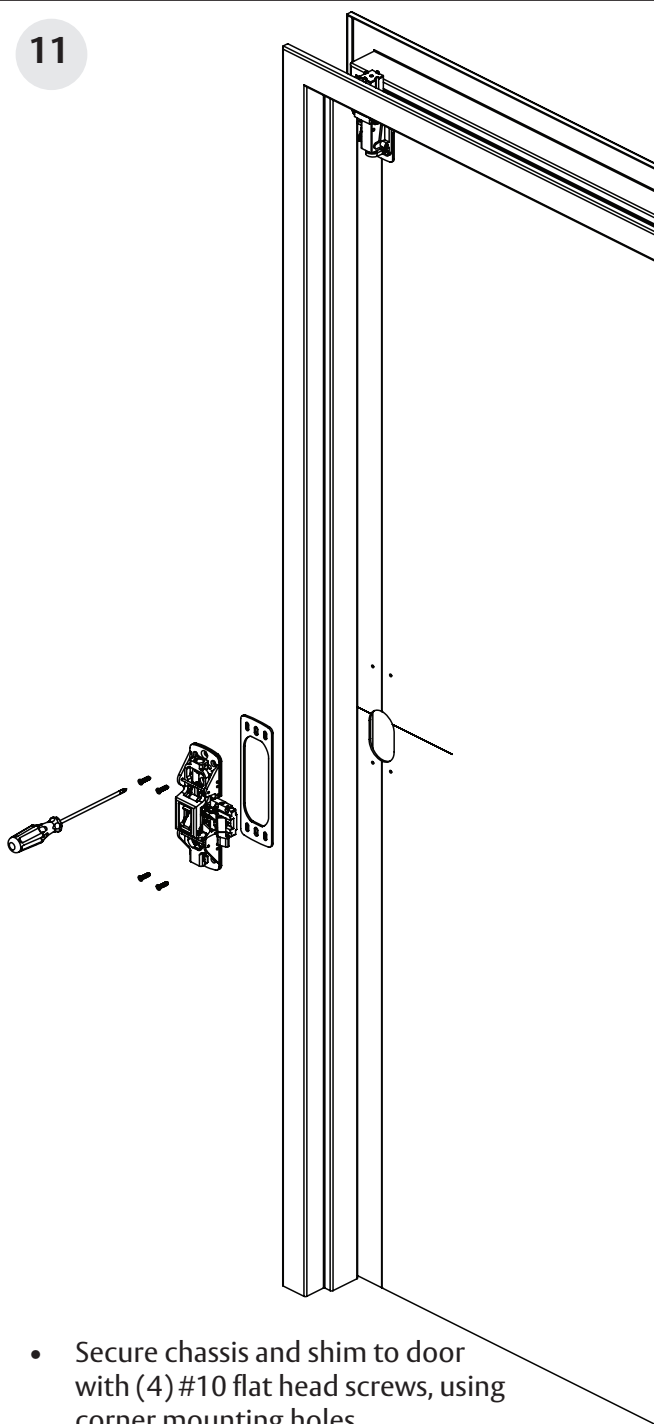

- Secure chassis and shim to door with (4) #10 flat head screws, using corner mounting holes.
- If trim is used, refer to step 11a.

11a

P700 Series ET Trim

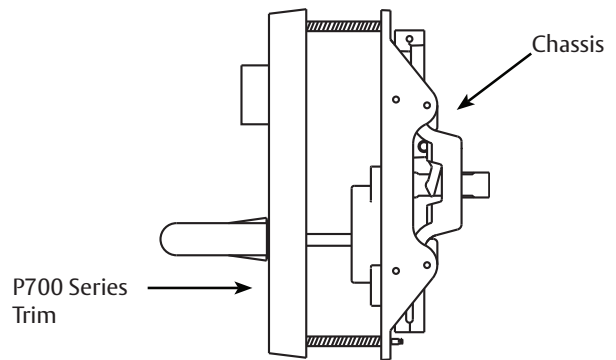

Position ET trim on door. Align spindle with bell housing. Thru-bolt chassis to ET trim with (2) 1/4-20 flat head screws.

12

Use breaking lines to shorten shim to the needed rail size



Refer to rail size listed on the box the device was shipped in. Break rail shim to the length that corresponds to the rail size.

Note: If shim needs to be cut, always cut shim from the end closest to the hinge edge.

FM-PE8700 Series

Surface Vertical Rod Exit Device

SARGENT

ASSA ABLOY

Installation Instructions

Rail cutting guide

If the rail doesn't need to be cut, continue to page 15 step 13.

If the rail must be cut, follow these steps on page 13 and 14:

Refer to the individual exit device installation instructions for rail cutting requirements / restrictions. Instructions will vary based on device type and options.

- Determine cut off dimension "X" by subtracting 2-7/8" from dimension "Y". Mark cut off point on mounting rail. (See below.)

Information for Cutting Rails		
Rail Sizes	Door Widths	
	Standard	Minimum
F	36"	33"
J	42"	37"
G	48"	43"

 Do not cut closer than 4" from the front edge of the rail insert.

Verticle reference line (C of chassis)

For doors with stile rail, the stile must overlap by 5/16" min.

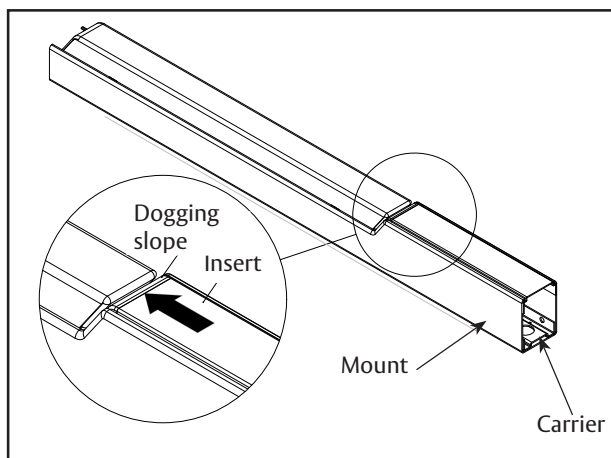
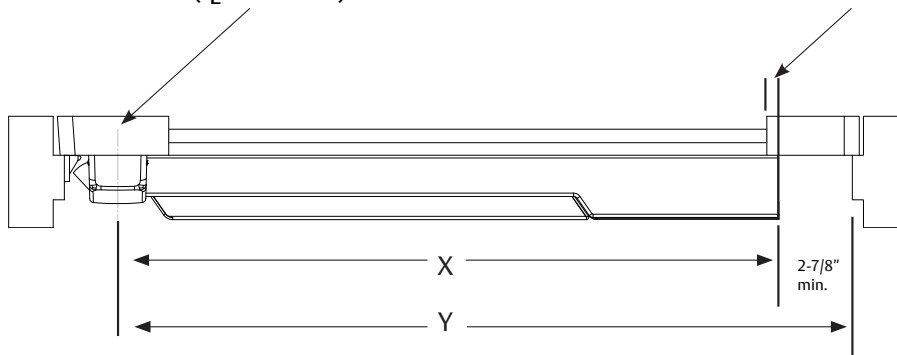

A. Ensure there isn't a gap between the insert and the dogging slope, and the carrier is flush with the mount.

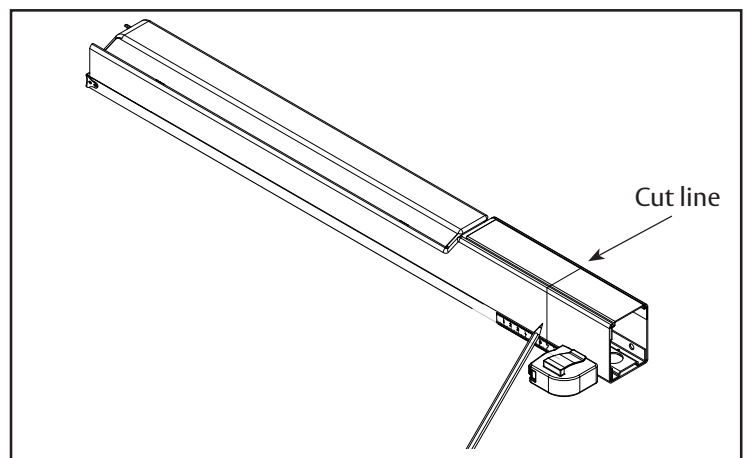

B. Mark rail at the required cut length.

FM-PE8700 Series

Surface Vertical Rod Exit Device

Installation Instructions



Rail cutting guide, continued.

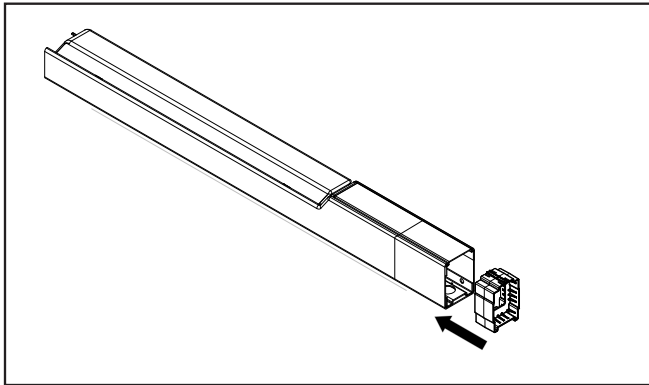

C. Ensure plastic insert support is installed under the cut line.

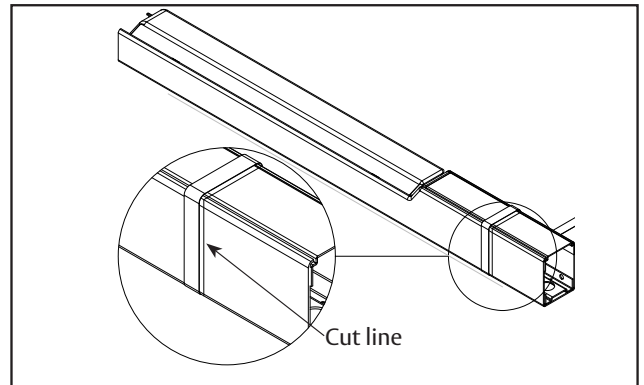

D. Wrap the rail and insert in masking tape, as shown.

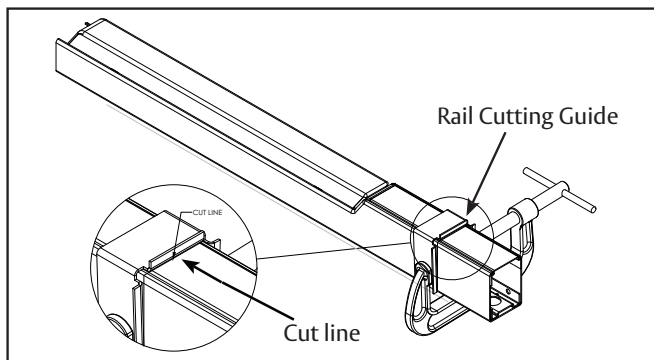

E. Place the rail cutting guide over the masking tape and align it with the cut line. Clamp the cut guide to the rail using a C-clamp.

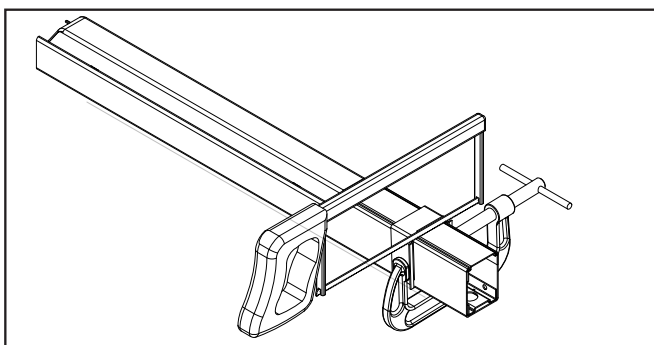

F. Using a hack saw with a new blade or a chop saw with a metal cutting blade, cut the rail, ensuring that the blade stays pressed against the rail cutting guide.

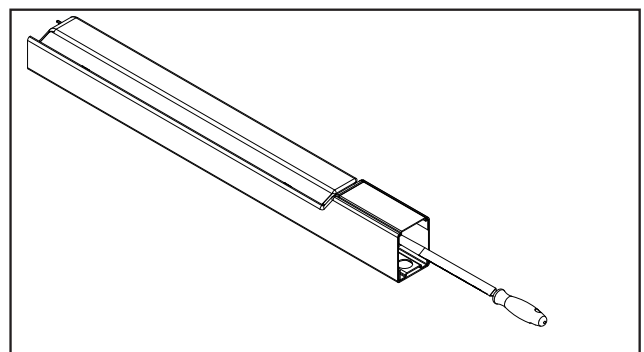

G. Deburr and smooth all cut edges with a file.

FM-PE8700 Series

Surface Vertical Rod Exit Device

Installation Instructions

SARGENT[®]

ASSA ABLOY

13

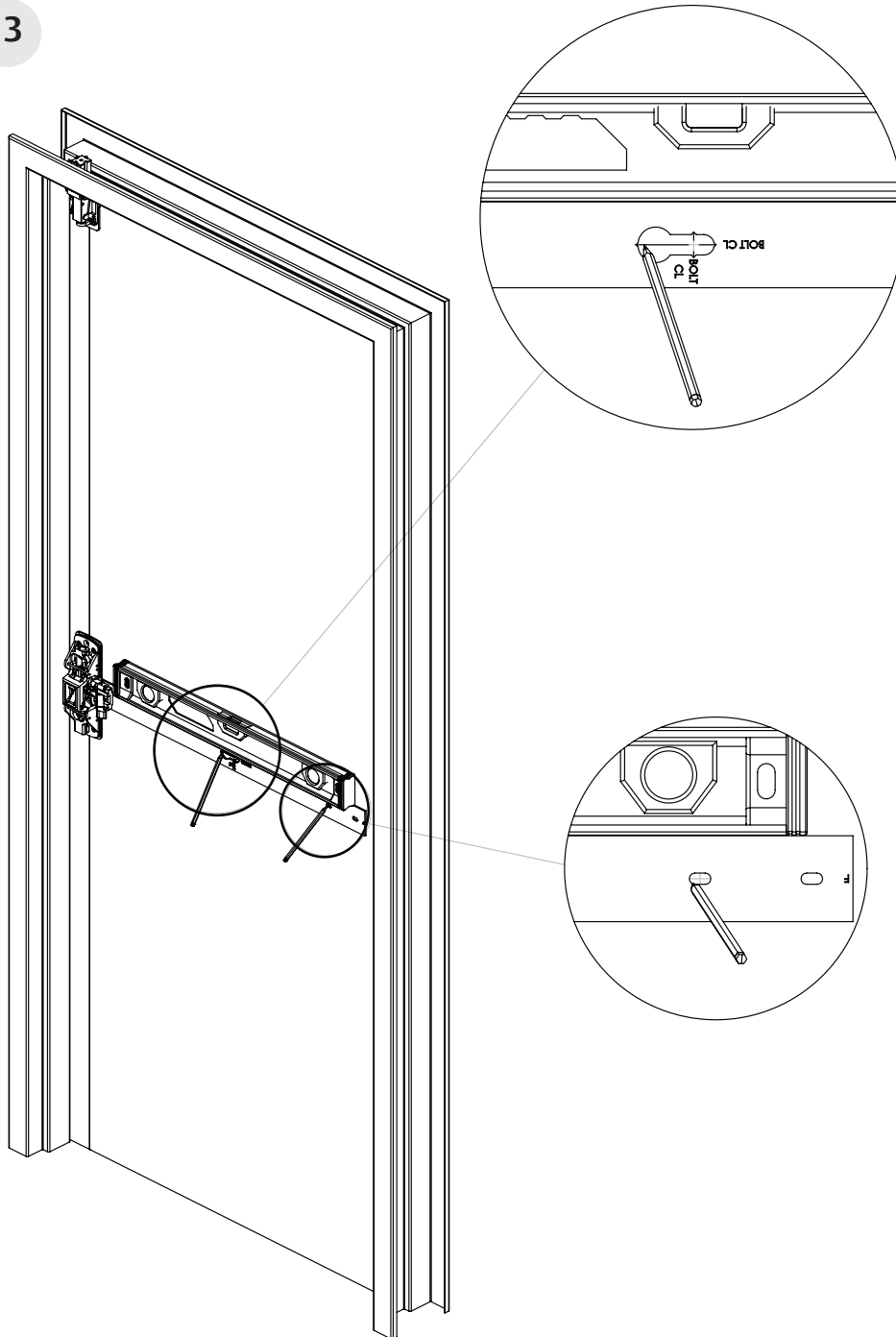

Level rail shim on the door and use it as a template. Mark the slot centerlines shown and punch locations for threaded holes where the centerlines intersect.

FM-PE8700 Series

Surface Vertical Rod Exit Device

Installation Instructions

SARGENT

ASSA ABLOY

14

Tracing from Step 13

Remove rail shim from door to expose tracing. Drill and tap (2) holes as shown in door surface. ("1" drill with 5/16-24 tap for hole at the middle of the door, #7 drill with 1/4-20 tap for hole closer to hinge).

15

Install rail retainer bolt (3/16" wrench).

FM-PE8700 Series

Surface Vertical Rod Exit Device

Installation Instructions

SARGENT

ASSA ABLOY

16

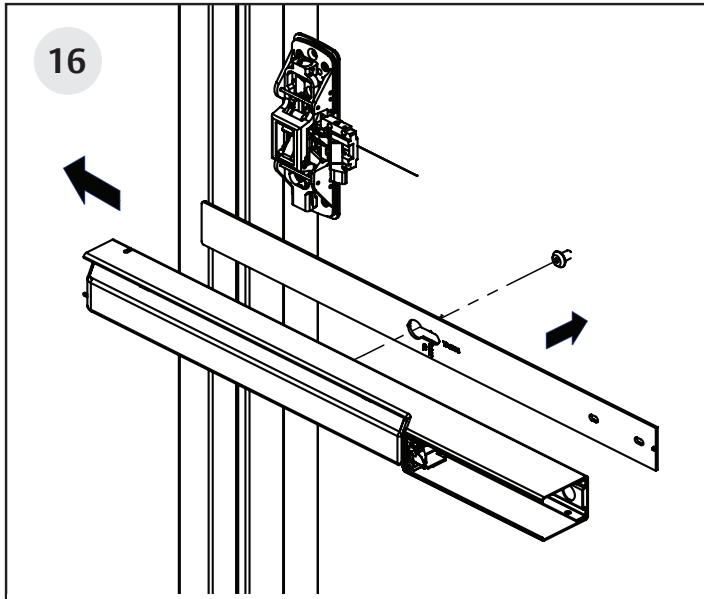

Depress chassis lift arm, and slide rail assembly with rail shim onto chassis. Ensure rail retainer bolt engages properly with slot in rail shim and rail assembly.

17

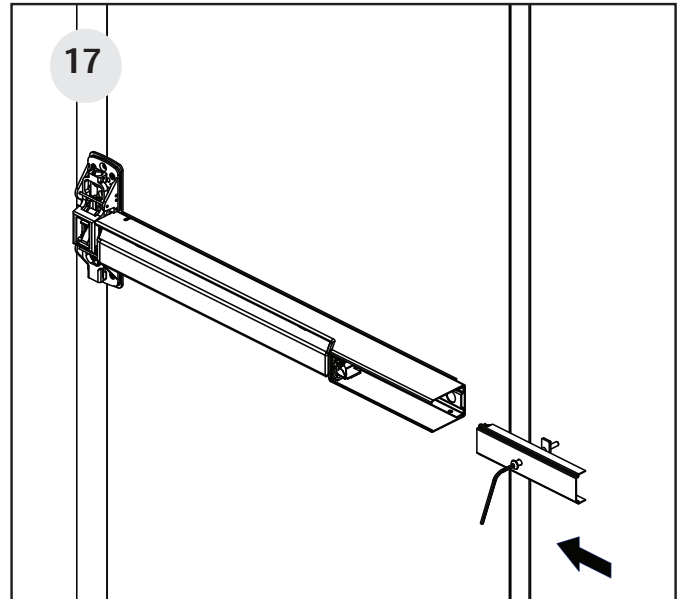

Install rail insert / shoulder bolt sub-assembly. **Do not fully tighten shoulder bolt.**

18

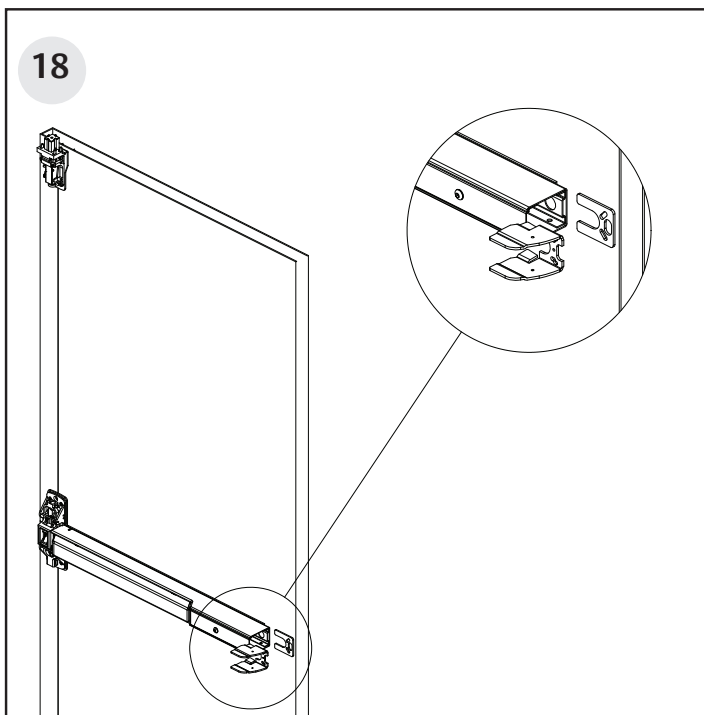

Insert the end cap bracket into the rail assembly with shim.

19

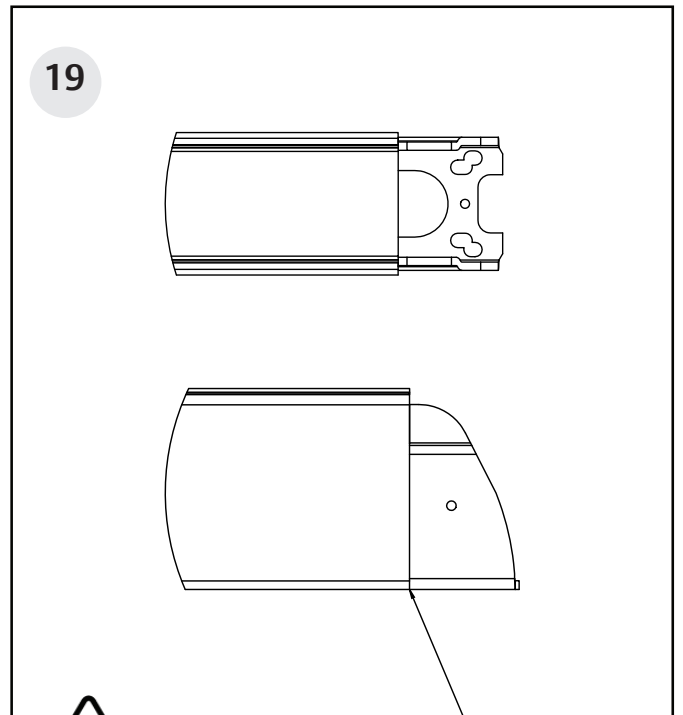

Ensure mounting rail bracket is against the rail without a gap.

FM-PE8700 Series

Surface Vertical Rod Exit Device

Installation Instructions

SARGENT

ASSA ABLOY

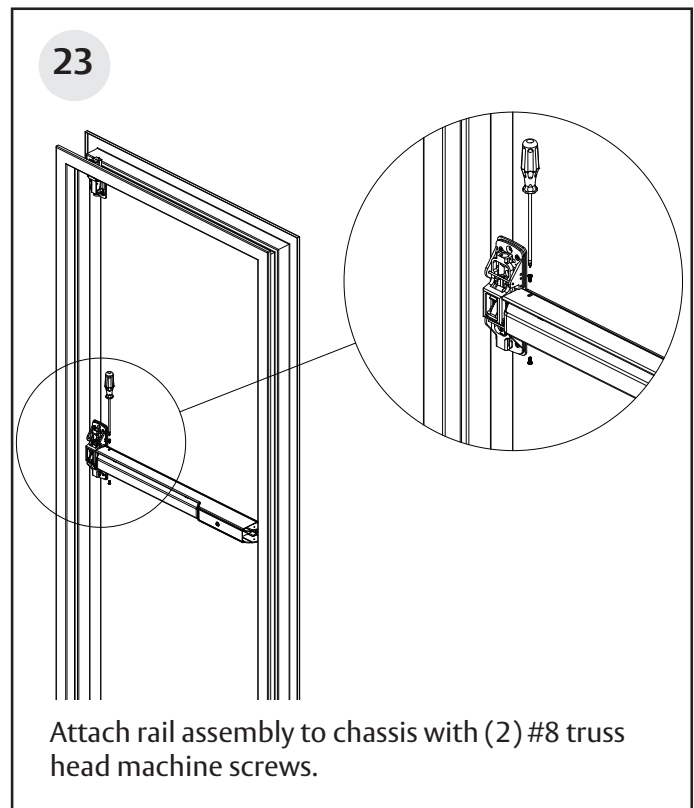
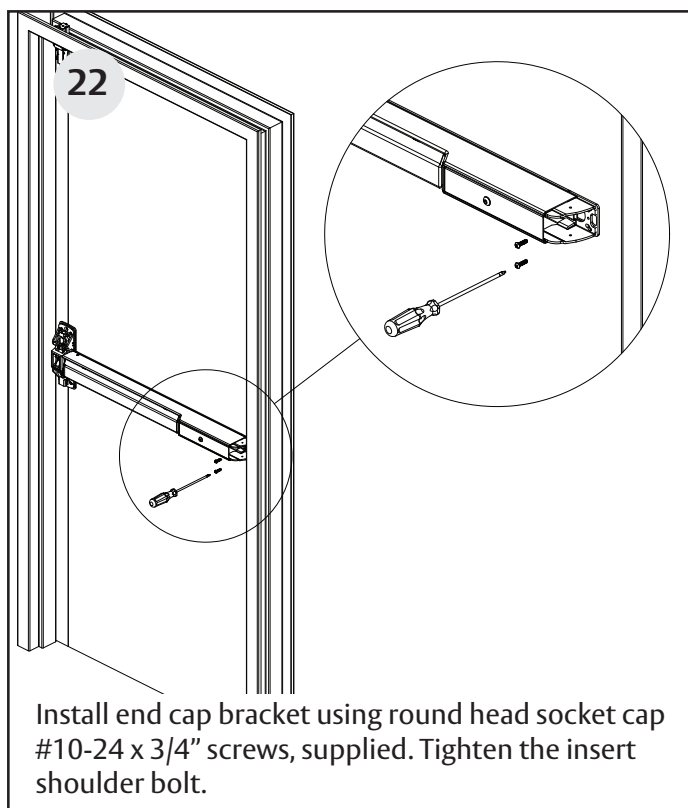
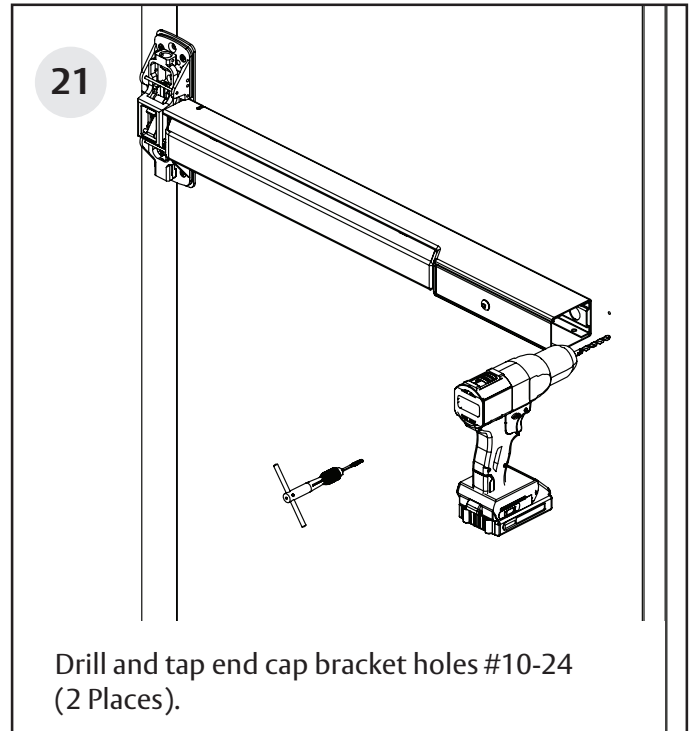
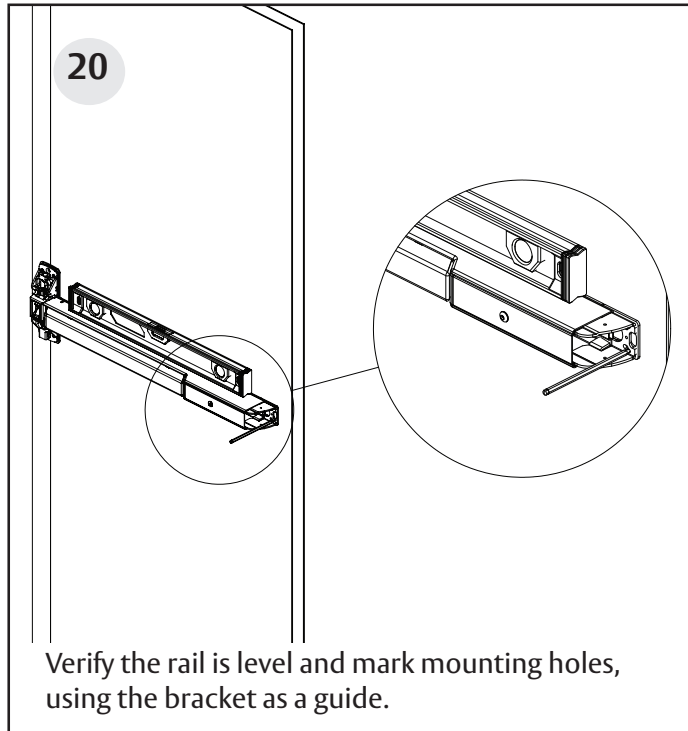

FM-PE8700 Series

Surface Vertical Rod Exit Device

Installation Instructions

SARGENT

ASSA ABLOY

24

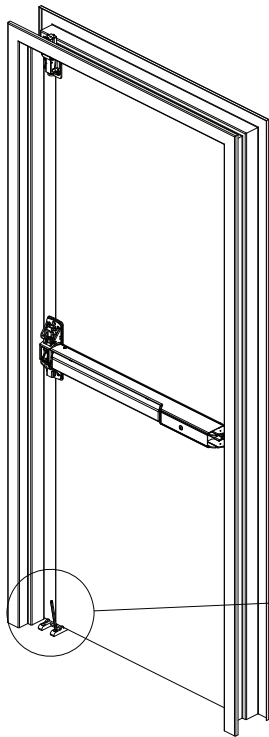

- Transfer vertical centerline to threshold.
- Align bottom strike.
- Mark and drill holes 1-5/8" to 1-3/4" deep for (3) 1/4" sleeve anchors.

Note: No clearance in floor is required.

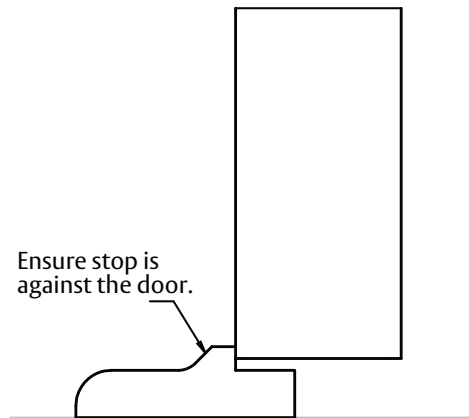
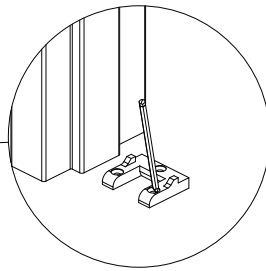

25

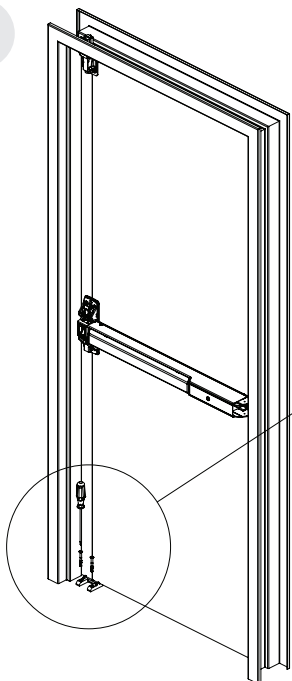

- Disassemble anchors and drop lower portion into the hole with threads facing towards the top of the hole.
- Align holes in strike with holes in floor.
- Screw the top half of the anchor onto the installed piece through the holes in the strike. Tighten the anchors.

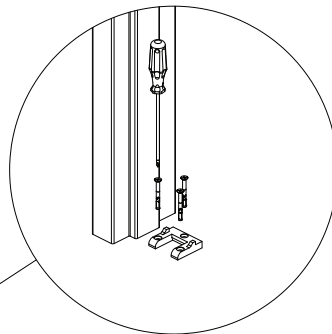

FM-PE8700 Series

Surface Vertical Rod Exit Device

Installation Instructions

SARGENT

ASSA ABLOY

26

Using the vertical reference line, with the bottom case as a template, align bottom case as shown. Mark (4) mounting hole locations.

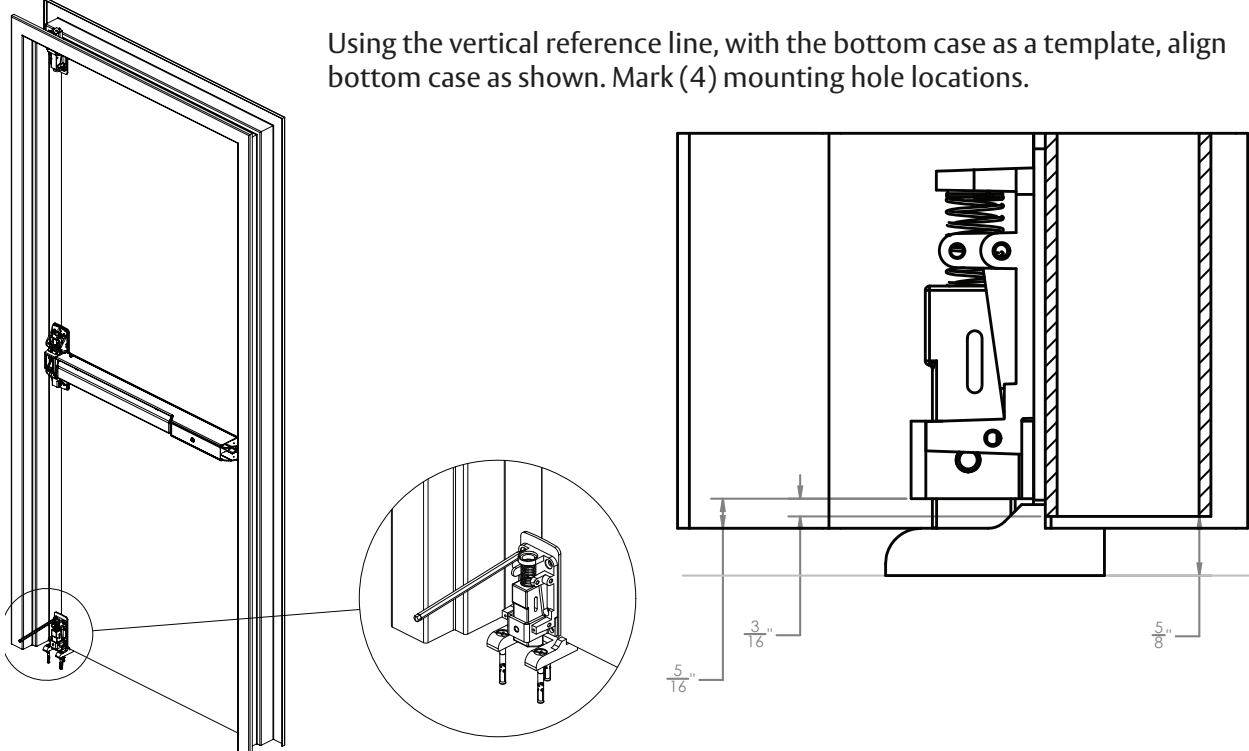

27

- Drill and tap top mounting holes for (2) #12-24 x 3/4" flat head socket screws, using 11/64" drill and #12-24 tap.
- Use 3/8" drill bit to drill two bottom mounting holes through door.

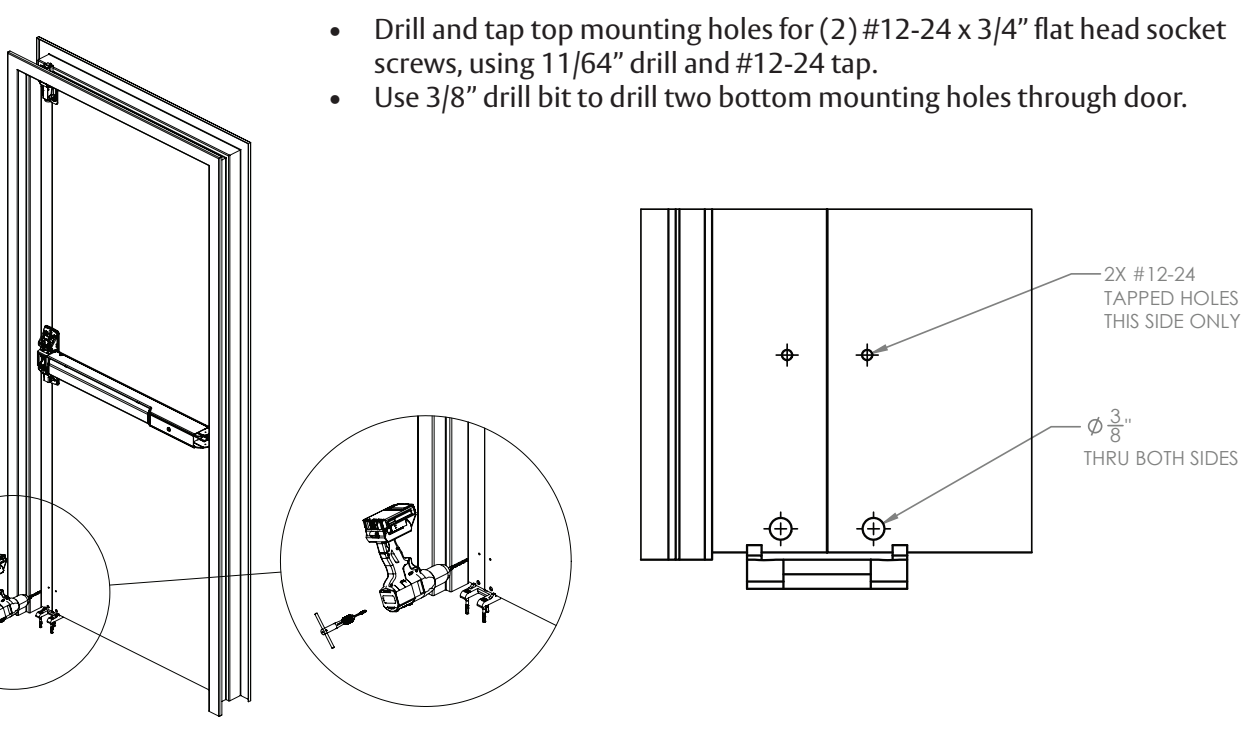

FM-PE8700 Series

Surface Vertical Rod Exit Device

Installation Instructions

SARGENT

ASSA ABLOY

28

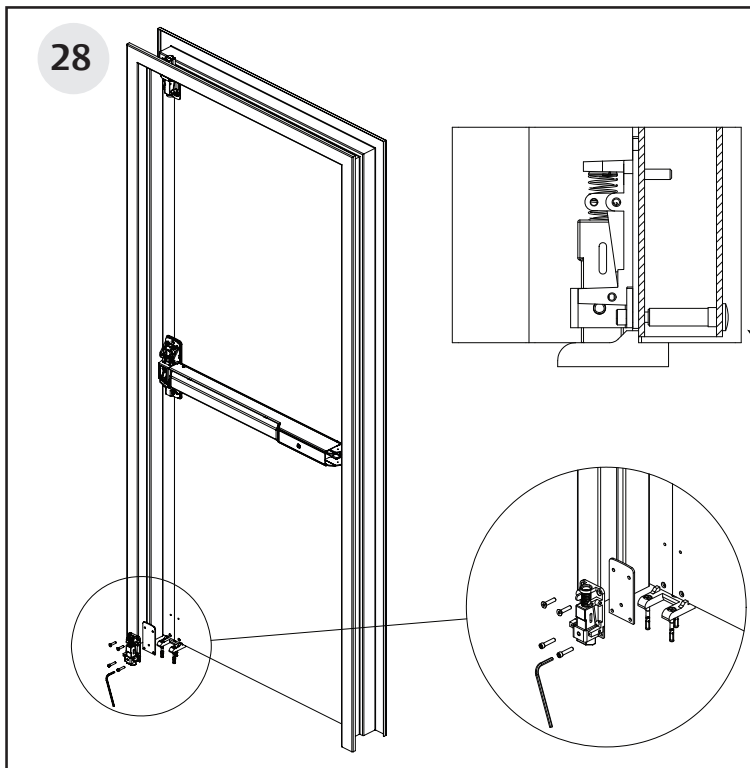

- Install (2) sex nuts from outside door surface.
- Install (2) #12-24 x 3/4 socket head cap screws from inside (bottom holes).
- Tighten screws with a 1/8" Allen wrench for the top, and 5/32" Allen wrench for the bottom.

Sex Nut (2)

29

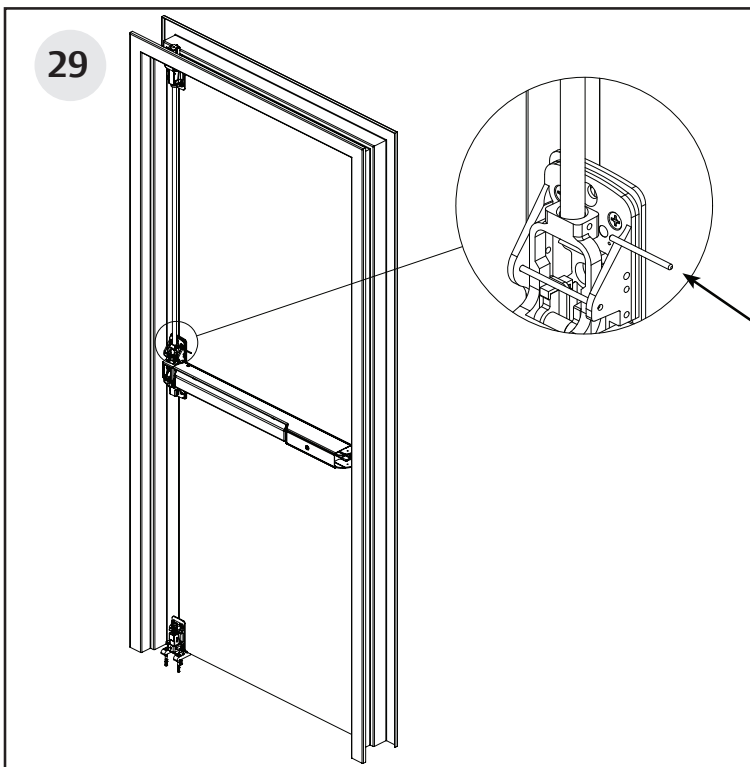

- Verify rail is not dogged (locked down). Slide top rod into main slide, center chassis.
- Thread top rod into top case until finger tight.
- Adjust position until the hole through the rod is aligned with the hole in the main slide.
- Insert rod adjustment pin.

Rod Adjustment Pin

FM-PE8700 Series

Surface Vertical Rod Exit Device

Installation Instructions

SARGENT

ASSA ABLOY

30

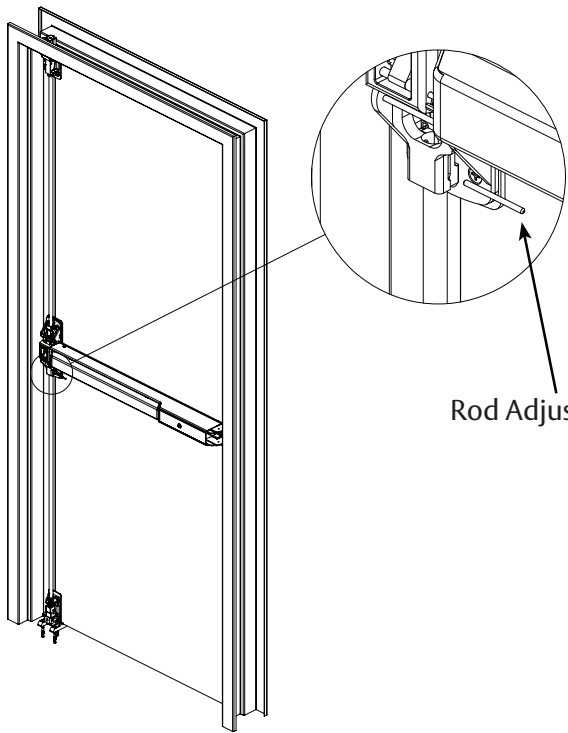

Rod Adjustment Pin

- Verify rail is not dogged (locked down).
- Slide bottom rod into main slide, center chassis.
- Thread bottom rod into bottom case until finger tight.
- Adjust position until the center hole is aligned with the bottom slot in the main slide.
- Insert rod adjustment pin.

31

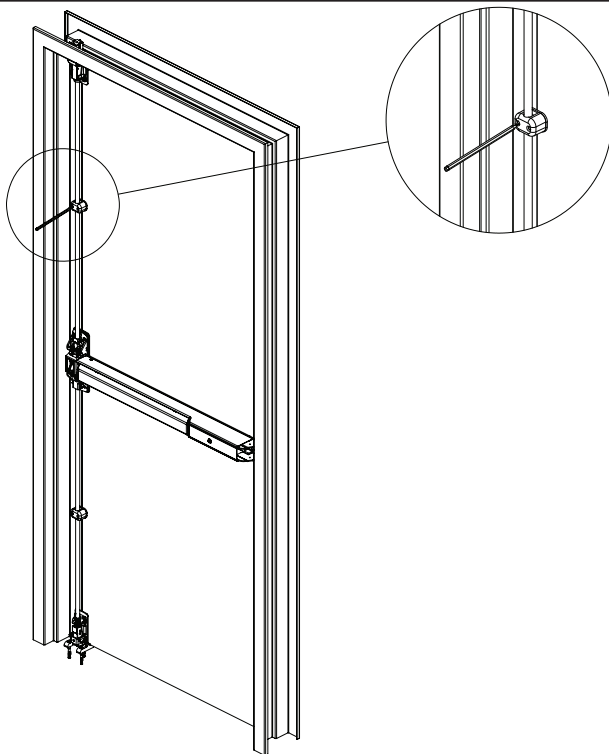

Align top and bottom rod guides at the mid-points between the center and top and bottom chassis. Mark mounting hole locations.

FM-PE8700 Series

Surface Vertical Rod Exit Device

Installation Instructions

SARGENT

ASSA ABLOY

32

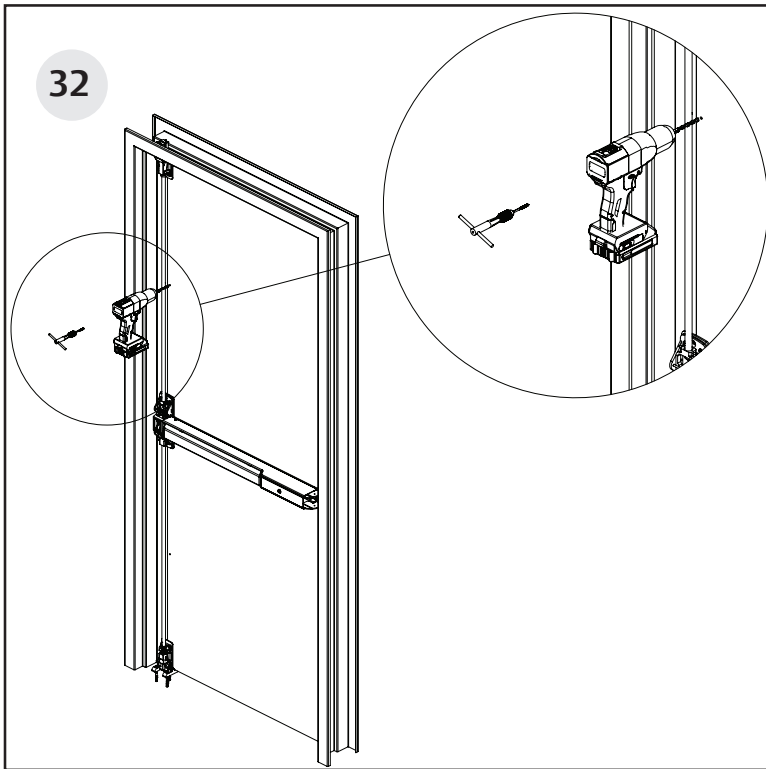

Drill and tap (2) #10-24 holes per rod guide.

33

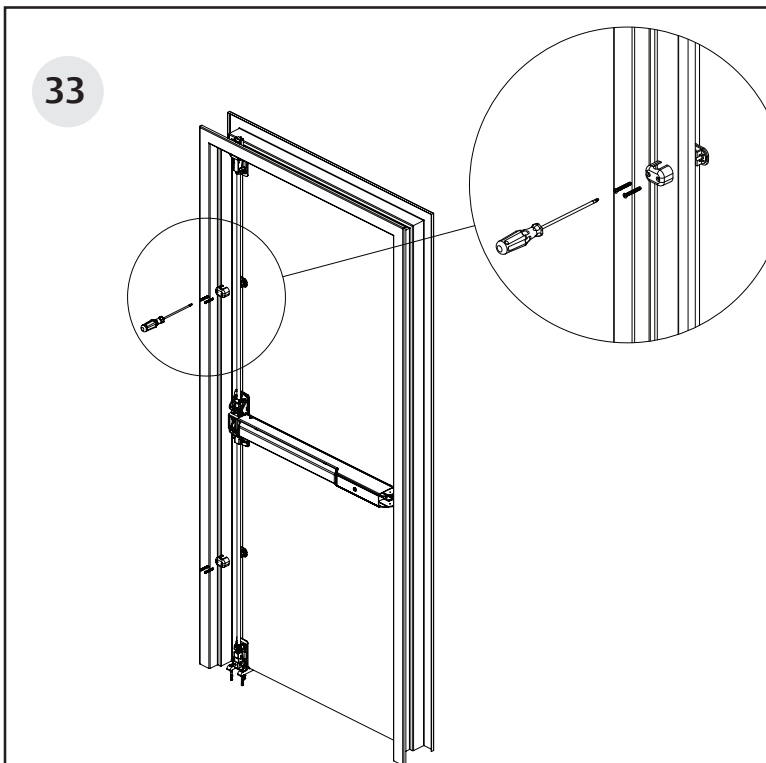

Attach rod guides and shims using (2) #10-24 x 1-1/4" oval head screws per rod guide.

34

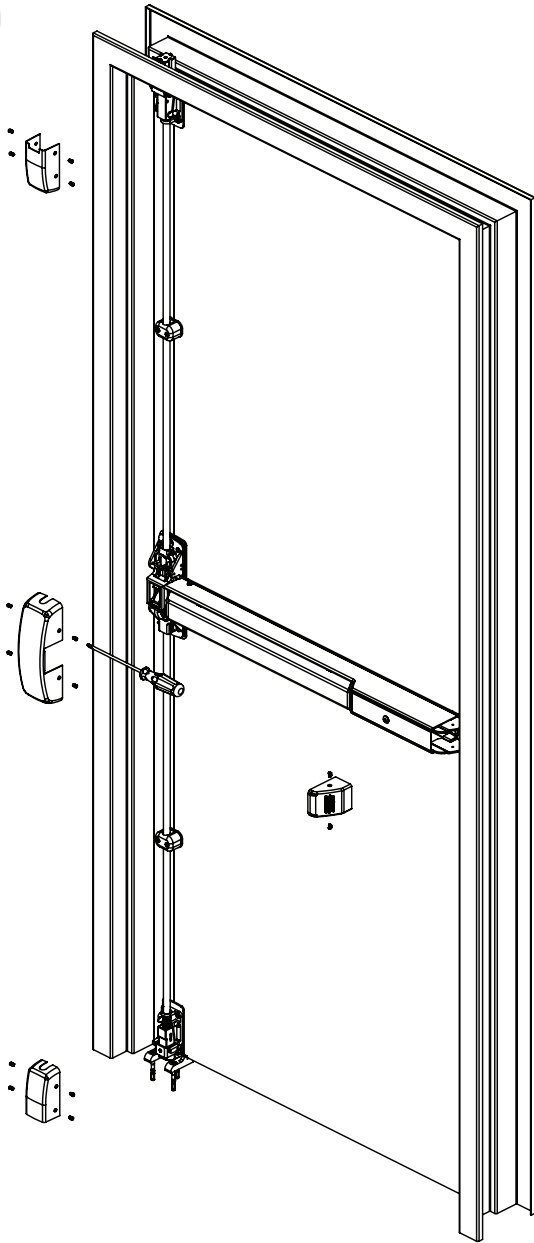

Install all covers using (14) #8-32 x 5/16" screws.

35

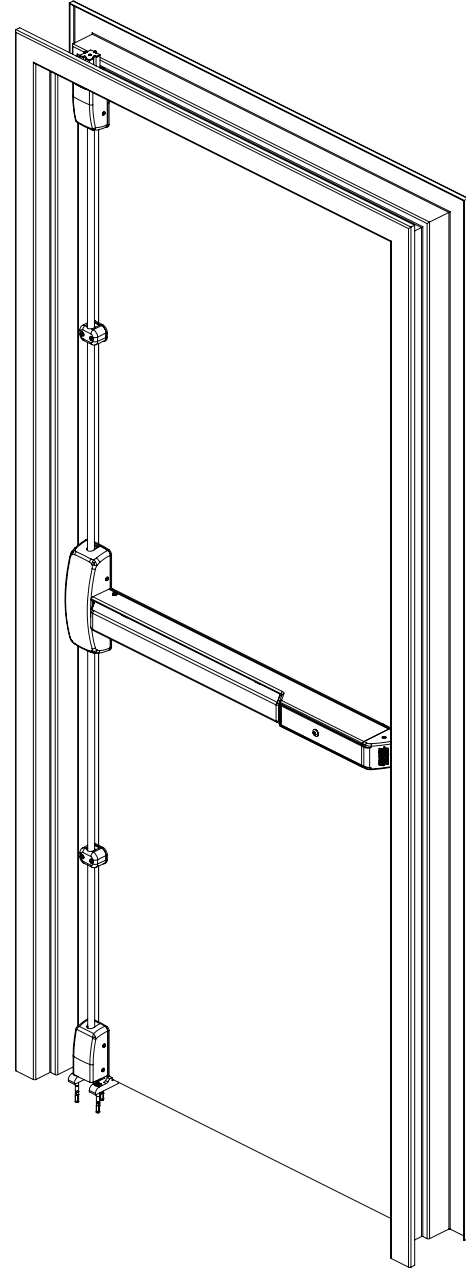

Check for proper operation.